

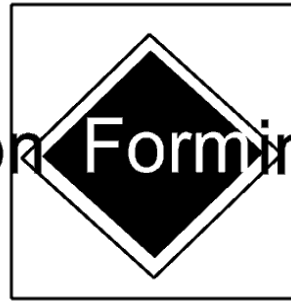

**Waukesha
Cherry-Burrell**

**Read and understand this manual prior to operating or
servicing**

1411P Bacon Forming Press



ANCO

*Effective Date
January 26, 2001*

ANCO

1411P Bacon Press

**Operation
Maintenance
Parts List**

Information contained in this manual is subject to change without notice and does not represent a commitment on the part of Waukesha Cherry-Burrell. No part of this manual may be reproduced or transmitted in any form or by any means, electronic or mechanical, including photocopying and recording, for any purpose, without the express written permission of Waukesha Cherry-Burrell.

Waukesha Cherry-Burrell All rights reserved

Revised Date **January 26, 2001**

Publication 95-03063

Warranty & Receiving Information

Waukesha Cherry-Burrell Warranty

Seller warrants its products to be free from defects in materials and workmanship for a period of one (1) year from the date of shipment. This warranty shall not apply to products which require repair or replacement due to normal wear and tear or to products which are subjected to accident, misuse or improper maintenance. This warranty extends only to the original Buyer. Products manufactured by others but furnished by Seller are exempted from this warranty and are limited to the original manufacturer's warranty.

Seller's sole obligation under this warranty shall be to repair or replace any products that Seller determines, in its discretion, to be defective. Seller reserves the right either to inspect the products in the field or to request their prepaid return to Seller. Seller shall not be responsible for any transportation charges, duty, taxes, freight, labor or other costs. The cost of removing and/or installing products which have been repaired or replaced shall be at Buyer's expense.

Seller expressly disclaims all other warranties, express or implied, including without limitation any warranty of merchantability of fitness for a particular purpose. The foregoing sets forth Seller's entire and exclusive liability, and Buyer's exclusive and sole remedy, for any claim of damages in connection with the sale of products. In no event shall Seller be liable for any special consequential incidental or indirect damages (including without limitation to attorneys' fees and expenses), nor shall Seller be liable for any loss of profit or material arising out of or relating to the sale or operation of the products based on contract, tort (including negligence), strict liability or otherwise.

SHIPPING DAMAGE OR LOSS

If your equipment is lost or damaged in transit, file a claim at once with the delivering carrier and ask for an inspector to view the damage. The carrier has signed the Bill of Lading acknowledging that the shipment has been received from WCB in good condition. WCB will assist you in every way in collecting claims for loss, or damage, however, WCB is not responsible for the collection of claims or replacement of materials. (See "Introduction" for detailed information on receiving and inspecting your equipment).

HIDDEN DAMAGE OR WARRANTY CLAIM

If during installation, you discover damage, contact the Shipper immediately. Notify your Distributor of the problem. In warranty claims you must have a returned goods authorization from the manufacturer before any returns will be accepted. Your Distributor will help you with a warranty problem. (See WARRANTY.)

Get results.



**Waukesha
Cherry-Burrell**

Customer Service

Telephone:

1-800-252-5200

Or 262-728-1900

Fax:

1-800-252-5012

Or 262-728-4904

To our international customers the country code for the USA is 1.
Also the "800" number can only be called in the USA.

E-mail: info@processequipment.spx.com

Website: www.spxpe.com

SPX Process Equipment
611 Sugar Creek Road
Delavan WI 53115

Table of Contents

Safety	1
Safety Curtain	3
Installation	3
Check-out Sequence	3
Trouble with Existing Installations	3
Window Cleaning	3
Polarity Check	3
Relay Replacement:	4
Relay Part Numbers:	4
Fuses:	4
Fuse Part Numbers:	4
Safety Curtain Warranty	5
Introduction.....	7
Set-up	8
Safety Guard	9
Operation.....	11
Start-up	11
Manual Operation Sequence	11
Auto Operation Sequence	12
Sequence of Hydraulic Valve Operations	13
Width Control Mechanism	15
Maximizer	15
Maximizer- Operating Instructions	15
Maximizer - Maintenance	15
Maintenance	17
Adjustments	17
Main System Relief Valve	18
Sequence Valves	18
Head Sequence	18
Side Sequence	18
End Sequence	18
Pressure Switch 1PS and Timer	18
End Relief Valve	18
Limit Switches Ls1, Ls2	19

Limit Switch, Ls3	19
Hydraulic Cylinder Cushions	19
Replacing The Cylinder Gland Packing	19
Removing the Gland	19
Installing The Gland	20
Adjustment Procedures	21
Troubleshooting	23

Safety

READ AND UNDERSTAND THIS MANUAL PRIOR TO INSTALLING, OPERATING OR SERVICING THIS EQUIPMENT.

Warnings, cautions and notes are contained in this manual. To avoid serious injury and/or possible damage to equipment, pay attention to these messages.

WARNING Hazards or unsafe practices which COULD result in severe personal injury or death and how to avoid it.

CAUTION Hazards or unsafe practices which COULD result in minor personal injury, product or property damage.

NOTE Important information pertaining directly to the subject information to be aware of when completing the task.

WARNING

To avoid electrocution, ALL electrical work should be done by a Registered Electrician, following Industry Safety Standards. All power must be OFF and LOCKED OUT during installation.

WARNING

Unexpected machine operation can be hazardous. Disconnect and exhaust all utilities from the machine before repair or adjustment.

This page is intentionally left blank

Safety Curtain

Refer to Infrared Safety Curtain Assembly drawing in Customer Print package for related information.

This device prevents “pressing” and returns press to “open” position if the operator reaches through the “curtain,” during a cycle”. Install and check as follows:

Installation

Align curtain by rocking or turning each one slightly on its vertical and horizontal axis. Keeping the units in alignment, tighten the brackets. A green lamp means the transmitter and receiver are properly aligned. A red lamp indicates misalignment. SHIM IF REQUIRED.

Check-out Sequence

1. Apply power to units and to the machine. If both the red and green lamps light simultaneously, clear the curtain to its green state by breaking the light curtain momentarily.
2. Interrupt the sensing field on the receiver side by passing a 2” diameter test bar from top to bottom of the face of the receiver. The red lamp should stay illuminated while the bar is present anywhere in the sensing field.
3. Interrupt the sensing field on the transmitter side by passing the test bar from top to bottom of the face of the curtain transmitter. The red lamp should stay illuminated while the bar is present anywhere in the sensing field. THE PRESS SHOULD STAY IDLE OR GO TO “OPEN” WHEN CURTAIN IS “BROKEN”.

Trouble with Existing Installations

If your curtain system has been operative in the past, remove either the transmitter or the receiver from its mounting, and place the units close together. If the units function normally, the problem is in curtain alignment or a weak LED output. Check to see if the unit’s mounting brackets have been bent, or if the units have been hit.

Be sure to check the items listed below before sending curtain units into the factory for repair.

Window Cleaning

Clean the windows of curtain units as necessary, using a mild solution of detergent and water, and avoid excessive rubbing.

Polarity Check

If, when power is applied to the system, the curtain receiver’s indicator lamps come up red and green, this may be indicative of a polarity problem. Interrupt the sensing field to see if the red/green condition clears. If it does not, you will need to perform the following steps in sequence, until the problem is resolved.

1. Remove power. Remove the factory-supplied jumper wire from the Ref and Neutral terminals. Place the jumper between the Ref and Blk/Hot. Reattach the power to the system. If the red/green lamp condition persists, perform Step 2.
2. Remove power. Remove the wires connected to the “A” and “B” terminals. Reverse them. Reattach the power to the system. If the red/green lap condition persists, perform Step 3.

3. Remove power. Remove the jumper wire from the Ref and Neutral terminals. Reattach the power to the system. If the red/green lamp condition persists, perform Step 4.
4. Remove power. Remove the wires connected to the "A" and "B" terminals and reverse. Reattach the power to the system.

Relay Replacement:

1. Shut down all power to both the machine and the curtain units.
2. Remove the receiver's cover.
3. Unplug the two relays from their sockets.
4. Plug in the replacement relays and reattach the strap, replace the receiver's cover.
5. Perform the "Check-out Sequence" on page 3 to verify that relay replacement is correct.

Relay Part Numbers:

Table 1:

Curtain Model	QTY	Part #
Shadow V	2	902182

Fuses:

The Shadow V has standard style ¼ x 1¼ glass tube fuses. Replace when necessary - DO NOT jumper.

Fuse Part Numbers:

Table 2:

Curtain Model	Location and Description	Qty	Part #
Shadow V	Receiver, Line, ¼ amp, 250 V	1	902180
	Transmitter, Line, ¼ amp, 250V	1	902180
	Receiver, Relay, 5 amp, 250V	1	902181

Safety Curtain Warranty

WARRANTY AND SERVICE INFORMATION

Data Instruments Inc. (D.I.) warrants that Data Instruments/Shadow devices are free from defects in material and workmanship under normal use and service for a period of one year from date of shipment. D.I.'s obligations under this warranty are limited to repairing or replacing, at its discretion, and at its factory or facility, any products which shall, within the applicable period after shipment, be returned to D.I. freight prepaid, and which are, after examination, disclose to the satisfaction of D.I. to be defective. This warranty shall not apply to any equipment which has been subjected to improper installation, misuse, negligence, or accident. The provisions of this warranty do not extend to the original warranty of any product which has been repaired or replaced by D.I. and no other warranty is expressed or implied. This warranty is necessarily limited to the quality of materials and workmanship in Shadow devices as they are supplied to the original purchaser; proper Shadow installation and maintenance become the sole responsibility of the user upon receipt of the device.

Make sure that supervisors, die-setters, maintenance persons, machine operators, and foremen have read and understand all instructions pertaining to the use of shadow devices.

Make sure that Shadow-equipped machinery (press, press brake, or other) is tested and inspected as specified by its manufacturer. Make sure, too, that such machinery is allowed to operate only when it - and its Shadow units - are both in proper working order.

Naturally the enforcement of these requirements is beyond Data Instrument's ability to control. Data Instruments does have available extra warning and test procedure labels. These are to be affixed to all Shadow units, and serve to remind personnel of the proper usage and maintenance procedures. Please write to the company if you require additional such labels.

Data Instruments manufactures its Shadow devices to meet stringent specifications, and cannot assume any responsibility for those consequences arising from their misuse. Shadow infrared presence-sensing devices are designed and built to protect machine operators and passersby from inadvertent access to pinchpoint hazards. In order to obtain such protection, Shadow users must properly install and maintain their Shadow units in accordance with this manual.

U. S. Patent Numbers 4,266, 124 and 3,805,061 apply.

This page is intentionally left blank.

Introduction

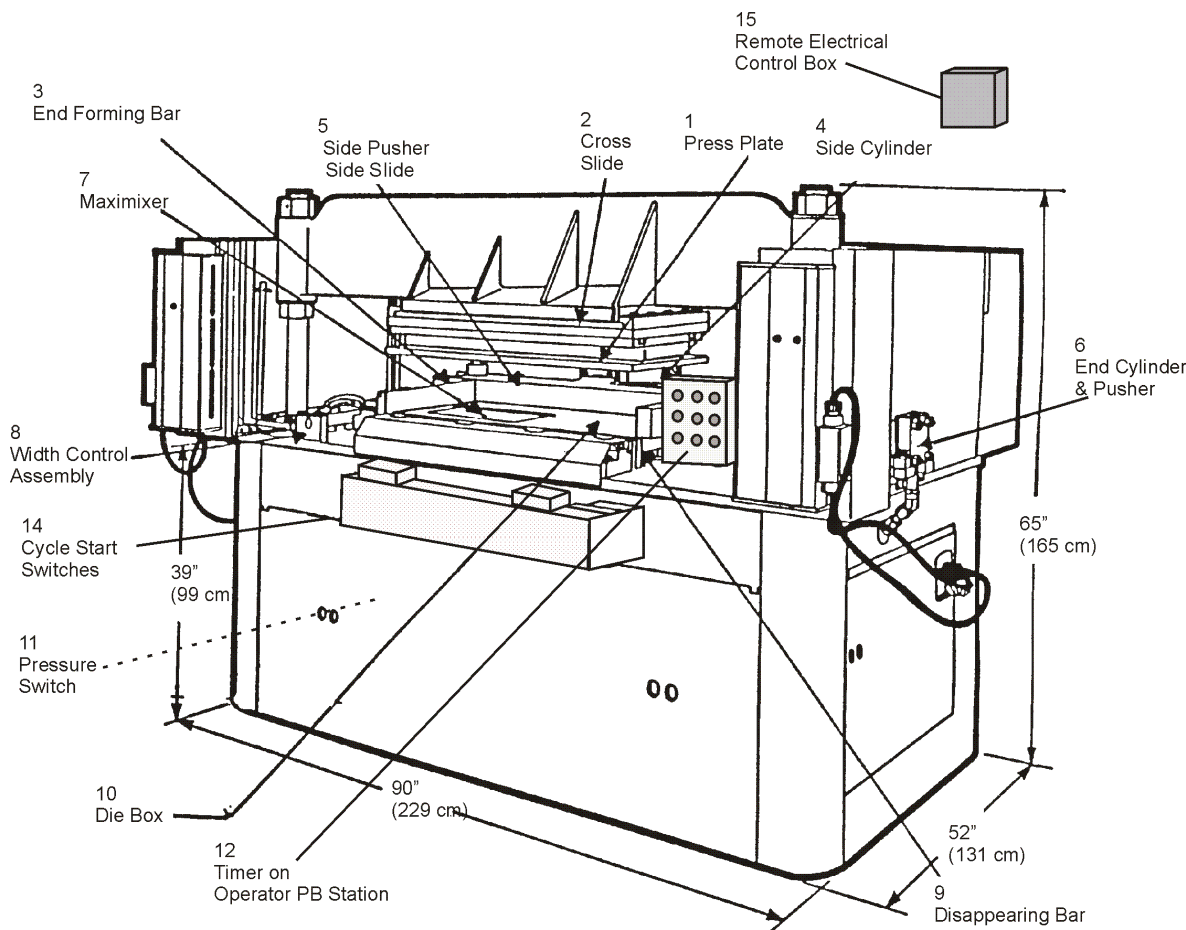

Figure 1 Bacon Press Foot Print and Major Components

These instructions cover installation, operation and maintenance of the Waukesha Cherry-Burrell Bacon Forming Press 1411P.

IMPORTANT

Instructions should be carefully reviewed and understood by all personnel involved in operating and maintaining equipment.

The information contained in this manual is provided to assist you in operating and

maintaining your ANCO No. 1411P Bacon Forming Press in the best manner possible. Proper maintenance will afford the maximum amount of efficiency and trouble-free service throughout the life of the machine.

The ANCO No. 1411P Bacon Forming Press is designed to form bacon bellies into a true rectangular shape so that they may be sliced with a minimum of waste.

The Width Control mechanism provided by this press will help the operator to determine the finished width of the pressed belly, subject

to the limitations imposed by the varying characteristics of the product. The characteristics that will ultimately govern the total amount a belly can be compressed without “cracking” are; temperature, type of feed in fattening the hog, etc.. Field testing on grain-fed bellies at 24° to 28°F indicates that a belly can be compressed to approximately 20% smaller than its maximum unpressed width, which after natural spring-back, will result in an approximate 10% permanent width reduction, squared for slicing.

The 1411P Press has a Bacon “Maximizer” assembly located in the bottom of the die box. The Maximizer inflates to provide a smooth yielding contour for the bacon to flow over during the pressing operation. At the final phase of the pressing operation, pressure developed by the bacon overcomes the pressure in the diaphragm. This allows the bottom of the bacon to flatten out without wrinkles in most bellies. The number and size of wrinkles is reduced in others.

NOTE: Recommend diaphragm replacement after 350 hours of operation or one month, whichever occurs first, or whenever diaphragm becomes deformed causing lifting of side pusher.

The 1411P Press has a Vari-Head Lock switch. The Vari-Head Lock can increase yield. The switch is a proximity type switch that the operator adjusts to a chosen thickness for pressing the belly. As the head moves down it stops at the switch and remains locked during side and end pressing. This feature prevents the head from floating up during side and end pressing. Should the head not be able to reach the setting it will lock in place once the end pressing begins. The head unlocks in automatic mode when the timer times out after pressing the end. When in manual mode, the head unlocks and rises when of the cycle start switches is released.

WARNING
Failure to operate and maintain the equipment in accordance with these instructions, or use of unapproved replacement parts, may result in injuries to persons and damage to property.

To secure operational information, repair assistance, or to order replacement parts, contact:

Telephone:
1-800-252-5200
Or 262-728-1900

Fax:
1-800-252-5012
Or 262-728-4904

To our international customers the country code for the USA is 1.

Also the “800” number can only be called in the USA.

E-mail: custserv@gowcb.com
Website: www.gowcb.com

Set-up

If you are not familiar with this machine, it is recommended that you have a service technician assist in the initial start-up.

The 1411P Bacon Press consists of the press and a remote electrical control box. The press is fully wired at the factory. The remote box contains the point for the customer power connection, the control transformer, two relays, pump motor starter and overload

module, PLC, and fuses. The customer must mount the Remote Box near the press and install wiring from the box to the press. There is no power disconnect switch in the remote box. The customer must provide the means for power disconnect.

1. Set the press into place.
2. Shim under the legs to level the table top, then securely bolt the foot pads to the floor to eliminate the possibility of “walking”.

CAUTION

Twisting of the table top due to lack of leveling can cause pistons to bind, or structural members to break.

3. Connect the lead wires located in the terminal box at the right rear hand corner of the machine, to the remote enclosure provided. The motor is factory wired. See Wiring Diagram furnished separate from the manual.

WARNING

To reduce electrical hazard to personal and equipment make sure to install a separate ground on the machine.

4. After completing the field wiring, check the direction of the motor rotation by pulsing the power ON and OFF. Proper rotation is counterclockwise looking at the fan end of the motor.

NOTE: The hydraulic pump will not pump if rotated the wrong direction. If pump does not raise the head, reverse two power leads and recheck.

IMPORTANT: Always block head when raised for maintenance, cleaning, etc. to prevent accidental falling and injury to persons reaching under head. Once the head has been raised, special care must be taken to wipe all of die box parts clean of dirt and grit which they pick up in shipment. Close the press by shutting it off with all three cylinders fully extended, exposing part of top of cross slide in forward position and top of press plate extending to left. Clean and inspect exposed area for any grit or foreign material, then apply a coat of grease to exposed areas. Jog the press open again and lubricate all grease fittings with a pressure gun, using #2 food grease. All of the grease fittings on the intermediate cross slide of Head should be lubricated every four hours.

5. After washing, blow off water and lubricate surfaces to minimize corrosion.
6. Check the temperature range in the room. If room temperature is between 25° to 65°F, use Chevron AW46 (ISO#46) hydraulic fluid, or equivalent. (This is the hydraulic fluid supplied.) Lower temperatures can be tolerated if a tank heater is installed to hold minimum temperature to between 25° to 65°F.
7. Check the hydraulic fluid level, a sight gauge is located at the lower rear of the press.

CAUTION

Keep the fluid level filled to the top of the high level mark.

Safety Guard

This bacon press is equipped with an operator protection device, an infrared safety curtain. It consists of two separate modules: a transmitter and a receiver, which form an

invisible curtain of infrared light in front of the press.

Power must be supplied to the guard. This is indicated by the amber light on the curtain transmitter and the green light on the receiver. It is essential for the transmitter and receiver to be properly aligned for the press to be operative. The red lamp illuminates any time the light field is not consistent between the two modules.

IMPORTANT: During clean-up, the transmitter and receiver should be removed from the press, stored in a dry location, and the cover caps installed on the wiring connectors on the press.

Up to 15 minutes warm-up may be required for the Safety Curtain circuitry. See “Safety Curtain” on page 3. For additional information on the guard, consult the data near the back of these instructions.

Operation

Start-up

WARNING

To avoid injury from electrical shock, inspect the Bacon Press to be certain it is properly grounded.

Before operating the press each day, lubricate all grease fittings located on the head sliding system, and on the front and end bars. These parts should be lubricated every four hours. Also, rub grease on the sliding components of the press mechanism.

Start the machine by pressing the “Pump Motor Start” push-button. This starts the hydraulic pump motor and supplies power to the control circuit. The side, end and top pressing plates remain in their normal retracted position.

It is recommended to have the motor and hydraulic pump run for several minutes up to a half-hour before operating the press, particularly if the room temperature is below that specified for type of hydraulic fluid being used.

Lubricate the top edge of the front bar and the top edge of left hand end bar with bacon grease to avoid scratching bars or the underside of the top platen.

CAUTION

Do not operate the press in continuous operation if the hydraulic oil temperature in the reservoir is above 180°F.

Manual Operation Sequence

The sequence of the Bacon Forming Press operation with the Selector Switch in the “MANUAL” is as follows:

1. Place belly in the die box.
2. Press both cycle start switches simultaneously and hold.
3. The front bar in the front of the die box immediately rises and the top platen head lowers until the belly is squeezed to the preset pressure.
4. As the head lowers it reaches the Vari-Lock Head switch LS8. The Head will only lock if the selector switch for Head Lock is turned On. If Head Lock is not desired it can be switched Off. The head stops and locks at the switch setting and remains in place during side and end pressing. Should the head not be able to reach the setting it will lock in place once the end pressing begins. There will be some overshoot of the setting. The scale beside the switch is adjustable to account for overshoot.
5. The (rear) side forming cylinder moves the rear of the die box to press the belly to the desired width control setting.
6. The end cylinder moves the right side of the die box inward to square the ends of the belly. The end pressure is limited by the end relief valve on the power unit.
7. Upon the release of the cycle start switches, the end cylinder retracts, the front bar lowers and the platen starts to rise to open the die box.

8. The side forming (rear) cylinder extends to eject the belly then retracts and the top platen completes its upward movement.
9. When the top press platen returns to the retracted position, the limit switches will automatically de-energize and vent line pressure back to the tank.

NOTE: The press will remain in the closed position at the end of the cycle until one of the cycle start switches is released. Releasing one of the cycle start switches or penetrating the light curtain will automatically de-energize the press cycle, immediately opening, ejecting, and returning it to the retract position.

Auto Operation Sequence

The sequence of the Bacon Forming operation with the Selector Switch in the "AUTO" position is as follows:

1. Press both cycle start switches and hold.
2. The front bar in the front of the die box rises and the platen lowers. When die box is closed, LS3 is tripped, turning on the "AUTO" light. The cycle start switches 4PX and 5PX are defeated by LS3, allowing operator to release cycle start switches - press will now continue the cycle.
3. As the head lowers it reaches the Vari-Lock Head switch LS8. The Head will only lock if the selector switch for Head Lock is turned On. If Head Lock is not desired it can be switched Off. The head stops and locks at the switch setting and remains in place during side and end pressing. Should the head not be able to reach the switch setting it will lock in place once the end pressing begins. There will be some overshoot of the setting. The scale beside the switch is adjustable to account for overshoot.

4. The (rear) side forming cylinder moves the rear of the die box to press the belly to the width control setting.
5. The end cylinder moves the right hand side of the die box inward to square the ends of the belly. The action of the squaring operation is continued automatically.
6. The elapsed time for squaring when in automatic mode begins when the 1PS pressure switch closes. 1PS switch is adjustable. Pressure switch 1PS is located on the power unit under the table and requires tools to adjust. The elapsed time for end pressing ends when timer 6TR times out. 6TR can be adjusted from 0 to 2 seconds by dial at the operator push button station on the press.

NOTE: The end pressure is limited by the end relief valve on the power unit.

7. When the set pressing time has elapsed, the end, and disappearing bar cylinders will retract and the platen rises to open the die box. **AT THIS TIME THE (REAR) SIDE FORMING CYLINDER EXTENDS TO ITS FULL STROKE TO EJECT THE BELLY.**
8. Upon ejecting the belly, the (rear) side forming cylinder retracts and the top platen completes its upward movement.
9. When the top press plate returns to the retracted position, the limit switch will automatically de-energize and vent line pressure back to tank.

NOTE: At any time during pressing cycle, the cycle may be halted, the cylinders retracted and the press opened by pressing the "EMERGENCY CYCLE OPEN" button or interrupting the Safety Curtain.

NOTE: Too narrow a width control setting will cause the belly to be extruded over the top of the front disappearing bar or cause “cracking” of the bellies. Also, it is not recommended to press a belly more than once.

Sequence of Hydraulic Valve Operations

For detailed schematics of the hydraulic and electrical systems refer to the Hydraulic Schematic, and the Electric Schematic in this manual.

1. With the pump motor started by pressing the “Pump Motor Start” button the hydraulic pump delivers oil through the valve manifold, through the main relief valve into the tank. Although the relief valve is in its vented position, a back pressure of approximately 40 psi will exist. At this time, the press is in its idle mode with all cylinders retracted and the die box open.
2. When the cycle start switches are depressed, the head down solenoid valve, front bar solenoid valves, and the main relief valves are energized. The main relief valve is now in its pressure control position which is factory set to provide a system pressure of 650 psi. Choosing the path of least resistance, oil flows through the front bar valve into the blind end of the front bar cylinder causing the bar to rise.
3. After the front bar raises, oil is now forced through the head down valve, through a flow divider and into the rod ends of the top plate or head cylinders. This causes the top press plate and head to move downwards until stopped by the head lock or resistance offered by the belly. When the Vari-Head Lock Switch LS8 is closed the Head Lock Pilot Valve solenoid is energized. The Head Lock Pilot Valve will only be energized if the Head Lock selector switch is in the ON position. If Head Lock is not desired it can be switched OFF. The pilot valve pilots the Head Lock Valve closed. The Head Lock Valve traps oil in both the rod end and blind end of the Head cylinders, locking the head in place.
4. Just prior to the complete stopping of the top press plate, sufficient pilot pressure is obtained to operate the side sequence valve causing oil to flow through the valve and into the blind end of the side forming (rear) cylinder thereby moving the side forming (rear) pusher into the belly.
5. After the side form (rear) pusher moves to a position that actuates the width control limit switch, the solenoid of the Side-End pilot valve is energized allowing the oil to flow through the valve and into pilot pressure lines of side and end sequence valves. The new pilot pressure in the side sequence valve is aided by a spring in the valve which overcomes the old pilot pressure on the other side of the valve spool allowing the valve to close thereby stopping the flow of oil to the blind end of the side forming (rear) cylinder and causing the side forming pusher to stop.
6. The pilot pressure to the end sequence valve opens the valve allowing the oil to flow through the valve, into the blind end of the end cylinder causing the end pusher to move inward.
7. At this time during the pressing cycle the functioning of the machine will vary depending upon whether the machine is set for “manual” or “automatic” operation.

If the machine is in “manual” operation the end pusher will continue to press the belly until the cycle start switches are released.

In “automatic” operation, the end pusher will press the belly for a period of time determined by the setting of the delay relay “6TR” started by pressure switch 1PS.

In both the “manual” and “automatic” operation the pressing force of the end pusher is controlled by the pressure setting of the end relief valve. This valve is factory set at approximately 550 psi. The pressure switch, 1PS, is set by the factory at a tripping pressure slightly lower than the pressure setting on the valve to insure that there is sufficient pressure in the system to operate the pressure switch. 1PS is readjusted at start-up to suit squaring of the ends. See “Pressure Switch 1PS and Timer” on page 18.

The end pusher stops inward movement when the pressure in the blind end of the end cylinder reaches the pressure setting on the end relief valve. When this occurs, the oil flows through the valve into tank.

8. Upon releasing the cycle start switches (“manual” operation) or the timing out of timer 6TR (“automatic” operation), the head down solenoid and the front bar and side-end pilot valves are de-energized.
9. Oil flows through the neutral of the head directional valve pressurizing the base ends of the top platen head cylinders and the side forming (rear) cylinder.
10. Oil also flows through the neutral of the front bar valve pressurizing the rod ends of the end cylinder and the front bar cylinder.
11. The spool of the side-end pilot valve is shifted allowing the pilot pressure supplied to the side sequence and end sequence valves to vent to tank.
12. During this part of the cycle the top platen head starts rising, the end pusher starts

retracting, the front bar drops and the side forming (rear) pusher moves forward to eject the belly. All of these movements will appear to occur simultaneously.

13. After side forming (rear) cylinder extends fully and the pusher ejects the belly, a limit switch is closed. This switch energizes the head up solenoid valve which opens a path that allows oil from the blind end of the side forming “rear” cylinder to pass through the side sequence valve and the head directional valve, and into tank, enabling the pressure on the rod end of the side forming (rear) cylinder to move the pusher rearwards.
14. At this time a limit switch, LS6 is closed causing the head down solenoid valve and the main relief valve to de-energize. The valves are shifted and the press is in its idle mode ready for pressing the next belly.

NOTE: At start-up when press is new, a cycle time of approximately five (5) seconds is normal. After a break-in period of several hours, a four-second cycle time can be expected.

CAUTION

If any problems occur in the operation of the machine, contact the ANCO (Waukesha Cherry-Burrell) Service Department for recommendations. Indiscriminate changing of pressure settings may cause damage to the machine. See hydraulic schematic for basic adjustments. Also review general maintenance section.

NOTE: The system pressures have been set to optimize the quality of the pressed belly and at

the same time minimize wear and heat generation in the bacon press parts. 750 PSI is the maximum system pressure setting advised and is seldom required.

Width Control Mechanism

The width control mechanism is located on the left side of the press table top. This is controlled by the position of switch LS4. It enables the operator to determine the width of the pressed belly. Drastic reduction in width cannot be done. There is a limit to how much width can be reduced during pressing. Some "spring back" also can occur after pressing. It can be set between 7 and 14 inches.

Maximizer

The Maximizer provides the smooth, yielding contour for the bacon to flow over during the pressing operation, for the elimination of wrinkles in the bacon slab being processed. At the final phase of the pressing operation, the pressure developed by the bacon overcomes the pneumatic pressure in the diaphragm of the Maximizer, allowing the bottom of the bacon to flatten out without wrinkles in a great percentage of the bellies and greatly reducing the amount and size of the wrinkles in others.

When the side disappearing bar lowers, LS3 is actuated. The air valve solenoid is energized. Air is introduced and pressurizes the space under the diaphragm. When the retraction cycle starts, the valve is de-energized, the air is exhausted, and the diaphragm is depressurized.

Maximizer- Operating Instructions

1. Introduce an air supply to the Maximizer circuit and set the air pressure regulator to approximately 35 psi. If the press is to be operated in a cooler, the filter-lubricator must be removed from the press and relocated outside the cooler to prevent

frozen condensation from clogging the air passages.

2. Follow the standard operating procedure described in "Operation Section" for the ANCO 1411P Bacon Forming Press. Bellies should be placed in the die box with the flank end to the left and the skid side down.
3. In the event of a rupture of the diaphragm, shut off the air supply to the Maximizer circuit. In the event the diaphragm cannot be immediately replaced, the press can be operated by removing the diaphragm assembly and using an appropriately sized lubricated plastic block as a filler unit. The blown-out diaphragm can be replaced.

Maximizer - Maintenance

1. The Maximizer assembly cavity in the die box should be cleaned daily. The Maximizer assembly may be removed for cleaning by disconnecting the quick-connect coupling in the line leading from the diaphragm to the air valve and lifting the diaphragm assembly out with the vacuum cups provided.
2. The life of the diaphragm will be increased if the Maximizer assembly is repositioned 180° after each cleaning.
3. The diaphragm may be replaced by removing the Maximizer assembly from the press, removing the nuts which clamp the Maximizer assembly together and replacing the defective diaphragm.

NOTE: Recommend diaphragm replacement after 350 hours of operation or one month, whichever occurs first, or whenever diaphragm becomes deformed causing lifting of side pusher.

This page is intentionally left blank

Maintenance

The press is equipped with two oil filters located near the pump at the rear of the oil tank, and a pump suction line filter and a return filter. When gauge indicators at filters descend to read “Needs Cleaning” or approach “Bypass”, the filter elements should be replaced. The wire suction element may be cleaned and reused.

Hydraulic oil can deteriorate with use. A complete oil change is recommended at least every 1500 hours of operation.

Once a week check under the press to see that all bolts are tight on the front disappearing bar, the die base and on the side or form end disappearing bar. Side and end pushers should be observed for any separation between shoulder of rod and pusher while retracting, separation indicates rod is backing out. If any of the above mentioned joints work loose, including bolts on the return linkage mounted on the press plate, bolts should be removed, cleaned, primed, loctited, and replaced. Check fittings under the table for hydraulic oil leaks.

CAUTION

The head will be unsupported on one side if any hose or fitting opens between either lift cylinder base and the flow divider inside the tank.

WARNING

The head will fall if any line is opened between the flow divider and the head sequence valve.

Block the head when opening any lines in these circuits.

The flow dividers and the head lock valve and related tubing are located in the tank at the access cover. Inability to develop pressure or head cocking might be caused by leaks or flow divider problems. Remove cover to check these items.

WARNING

Hydraulic oil leaking under pressure can penetrate your skin and cause infection. Do not expose fingers and hands to pressure leaks.

Adjustments

Review electric and hydraulic schematics and the power unit assembly drawings, all included in the print package. Review sequence of valve operations. The 1411P Bacon Press Hydraulic system uses a combination of pressure and electrical sequencing that will produce best results when properly adjusted. The pressure adjustment available on the sequence valves and relief valves IPS can produce significant variation in the cycle of the machine and the product placed in the press, so particular attention should be paid to the adjustments and the results of changes in these settings.

The power unit when running with press idle, should be in an unloaded state. This means the gauge on the main relief valve should indicate approximately 40 PSI. This low pressure bypass condition will allow the fluid to stay cool. The valve will bring the pressure up when the solenoid is actuated or the manual override is depressed.

NOTE: Do the following adjustments in order as listed.

Main System Relief Valve

The solenoid on the main relief valve must be actuated in order to set the pressure. This can be done by pushing the override centered in the solenoid coil housing, or, by holding a steel screwdriver blade against Limit Switch LS5. LS5 is the proximity switch at the end of the width control, closest to the operator. Relief pressure is read on the gauge as the knob is adjusted. 650 PSI is typical relief setting and should be lower if possible to keep oil cool. Close gauge valve after adjusting to protect gauge against “spikes”.

Sequence Valves

The sequence valves are the large valves without electrical hookups, but with large tee handle adjusting knobs to set the shift pressure between 0-500 PSI. These valves are normally closed and open when the sensing port reaches the set pressure.

Head Sequence

Screwing in increases the pilot pressure required to open and to allow the head to press. Screwing out too far will allow the head to drift down at idle, bumping up and down, and cycling on Limit Switches LS1 and LS2 attached to the Head Cylinders.

Properly adjust by screwing out until Head begins to fall at idle. Screw in about two turns and lock.

Side Sequence

Screwing in delays the extension of the side (rear) cylinder. Screwing, out allows the side (rear) to extend earlier in the cycle. Properly adjust to extend about 2 inches before head is down. Make sure the side (rear) pusher does

not push on the belly too soon before the head is down.

End Sequence

The end sequence valve is adjusted similar to the side sequence and controls the End Cylinder. Screwing in delays extension. Screwing out lets the cylinder extend sooner.

Pressure Switch 1PS and Timer

The pressure switch senses pressure in the blind end of the End Pressing Cylinder. The Timer begins timing when the pressure switch closes. Adjust the pressure switch with the timer initially set to zero. The pressure switch is located on the power unit under the table of the press. In automatic mode, adjust the pressure switch so that the End Pusher makes contact with the end of the belly and presses lightly for a very short time before the press opens. This will insure that the pressure switch closes as soon as possible to save cycle time. It should be closing as soon as a little resistance is met. The pressure switch must be set lower than the End Relief Valve. If it is set above the End Relief Valve the pressure will relieve and the pressure switch will not close.

Next adjust the timer. The timer is controlled by the dial labeled "End Pressing Time" on the operator station. The timer regulates the elapsed time for end pressing. The elapsed time starts when the pressure switch closes and ends when the timer times out and the press opens. Adjust the timer up from zero just enough to square the end of the belly

End Relief Valve

The end relief valve is a small “cartridge” type relief valve with a hollow hex cap screw adjustment. It regulates the pressure applied to the product by the End Cylinder. 550 PSI is the factory setting.

Limit Switches Ls1, Ls2

These switches are mounted one at each Head Cylinder and are open with Head up and closed at any other position.

Limit Switch, Ls3

This switch is located under the Side (front end) Disappearing Bar. It is adjusted to close just as the Top Plate meets the Front Disappearing Bar and Side Disappearing Bar. Thus the auto cycle engages as soon as those pinch points are closed allowing operator to release the cycle start switches and the cycle to proceed.

Hydraulic Cylinder Cushions

Small socket screw heads may be found flush at the sides of cylinder heads or caps. These may be screwed in to increase cushion action at end of cylinder stroke or screwed out to decrease such action.

This adjustment is critical at the lower end of the Front disappearing Bar Cylinder. Excess cushion can slow the cylinder and cause the ejected belly to be “snagged”. Insufficient cushion allows the cylinder to “band” at end of stroke causing noise and vibration.

Replacing The Cylinder Gland Packing

Fluid leakage around piston rod at the gland area will normally indicate a need to replace gland seals. First, remove cylinder from machine to which it is mounted or, if this is not feasible, disconnect the piston rod from rod clevis, knuckle or machine member to which is fastened.

The “Jewel” gland is a unique cartridge design consisting of a bronze gland, primary lipseal and double lip wiper seal. It is threaded into

the gland retainer plate, and all sizes are removable without disturbing the tie rod torque.

Removing the Gland

1. Inspect the piston rod to make sure it is free of burrs or other displaced metal which would prevent sliding the gland off the rod.
2. Unscrew the gland (right-hand threads) from the gland retainer plate.

NOTE: On 8” bore or larger air cylinders or low pressure hydraulic, remove the bolted gland retainer by loosening the 4 socket heads crews. The gland protrudes from the face of the retainer and can be removed with vice grip pliers or a gland wrench which is available for each gland size.

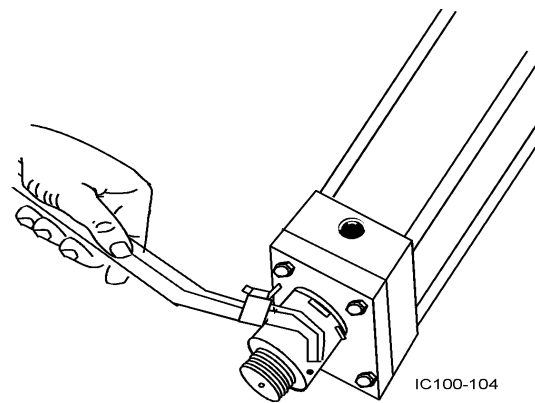

Figure 2 Gland Wrench

3. Slide the gland off of the piston rod and remove the seals.
4. Thoroughly clean the gland and seal grooves.
5. Inspect gland bore for wear. If bore is worn, replace using gland cartridge kit containing seals for proper class fluid.

6. If gland is worn, replace seals only, using rod seal kit containing seals for proper class fluid. (See following page.)
7. Lubricate gland seal grooves and all new seals.
8. Install wiperseal, (See Figure 3 item 40), in groove closest to end of gland. Slightly collapse back-up washer, (See Figure 3 item 43), and install in seal groove. Make sure it is flat against wall of groove.
9. Install lipseal, (See Figure 3 item 41), in seal groove. Lips of seal should point toward the long bearing side of gland.

An O-ring. (See Figure 3 item 45), is supplied with each gland cartridge kit. It serves as a seal between the gland and the head. This O-ring is a static seal and does not normally require replacement. The original O-ring may be left in place, unless it is known to be leaking (fluid flow around gland thread).

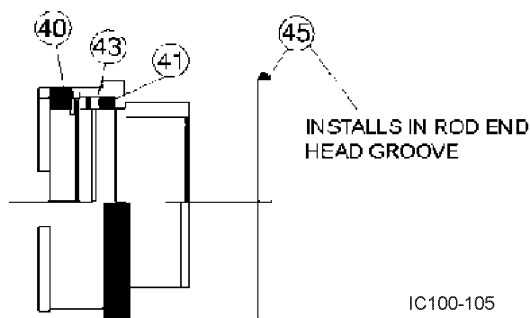

Figure 3 Installation of Gland

Installing The Gland

Before installing a new gland, inspect the surface of the piston rod for scratches, burrs, dents or other damage. A damaged piston rod surface will result in premature rod seal failure. Lubricate the bore of the gland and the seals, and slide the gland over the end of the piston rod.

10. Thread the gland into the retainer until it is seated firmly against the head. The gland-to-head O-ring, (See Figure 4 item 45) serves as a torque prevailing lock.

NOTE: The seals are pressure actuated, so no further adjustments are necessary.

When replacing a gland on a rod which is threaded to the full diameter or so shaped that it could damage the seals, a slight rotary motion of the gland will help prevent damage. In addition, because full-diameter threads are usually supplied with the crest of the threads slightly truncated, a piece of shim stock or other thin, tough material can be wrapped around the threads to help protect the gland seals when they are being passed over the threads.

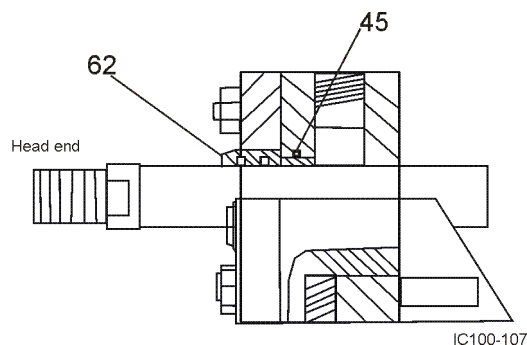

Figure 4 Head End O-ring Seal

Table 3: Cylinder Gland Packing

Hydraulic Cylinder	Piston Seals ANCO Part #	Body O-Rings ANCO Part #	Heavy Duty Rod Seal Assembly ANCO Part #
Special Top Plate Lift 4x6x2-1/2 Rod	720116	720115	722182
Side Forming (Rear) 4x10x2-1/2 Rod	721786	720115	722182
End Forming 3-1/4x16x2 Rod	721787	720112	722181
Front Disappearing Bar 2x3x1 Rod	721785	721783	not required

Adjustment Procedures

During initial start-up, basic adjustments were made to ensure proper operation of the press. Over a period of time, these settings will change and the press will require readjustment. Prior to taking corrective measures listed on the Trouble Shooting Chart, make basic adjustments as listed "Adjustments" on page 17.

This page is intentionally left blank

Troubleshooting

The PLC has LEDS for each input and output. The LED lights when the input is energized or when the output is energized. Basically the inputs are connected to limit switches and operator switches. Basically the outputs are connected to valve solenoid coils or indicator lights. The LEDS can be used when troubleshooting as an indication that a particular input or output is being energized.

PROBLEM	POSSIBLE CAUSE	SUGGESTED ACTION
Side cylinder #4 jerking forward and back violently. System pressure main relief valve stays activated when press is in idle.	LS1 or LS2 is staying closed all the time. Both switches are normally closed and are held open when head is fully up and in idle and should close as soon as head starts down.	These switches are open when head is fully up. Replace switches.
Head bounces up and down when press in idle.	Set pressure too low on head sequence valve.	1) Increase pressure on valve (screw down). 2) Malfunctioning valve, repair or replace. 3) Check LS1 and LS2 for proper action as above.
Very low or no system pressure.	Solenoid spool not shifting on main relief valve.	1) Manually override solenoid spool if system pressure goes to normal, replace solenoid. 2) Malfunctioning valve. Repair or replace.
Press does not open at the end of the cycle.	1) Pressure switch not closing. 2) Timer not timing out. 3) LS5 switch not making.	1) Lower pressure switch setting if still not closing, replace. 2) Replace Timer. 3) Relocate LS5 or replace.
Same pressing from end pusher all the time. Over pressing large bellies, not squaring off small bellies	Pressure switch staying closed all the time.	Check PLC input light #9. If it is always on then, pressure switch is staying closed. Increase pressure setting. If pressure switch still does not open, replace switch.
Head cocked when press is in idle.	Rods for head cylinders are threaded into cylinder pistons. Measurements between die box #10 & bottom of press plate #1 is 6-5/8. If one side is over it is possible that the rod, on that side shaft has backed out of piston.	Remove piston from shaft, clean, prime and LOCTITE threads before re-securing.

Head cocks during pull down.	Broken, loose, or cracked tubing inside of tank between flow dividers) head lock valve & manifold.	Remove access cover on front, top, left hand side of hydraulic tank in front of manifold. Do not cycle press. Pressurize system by using manual override on "G" valve solenoid. Oil will become violent in area of leak.
Pump noise. "Milky" Oil.	Air leak in suction piping, dirty oil or water in oil.	Tighten fittings and joints. Change filters and/or change oil. Change oil and determine source of water.
Press will not cycle.	Shadow Failure.	See drawing section of this manual.
End pusher hesitating at the end of stroke adding to cycle time of press.	Timer 6TR, #12, set too high.	Decrease "delay on" timer (6TR).
End of belly not being squared off.	Pressure switch #11 set too low. Timer 6TR, #12, set too low.	Increase closing pressure of pressure switch. Increase "delay on" time of timer (6TR). End Relief Valve set too low. When Head Lock is on, more pressure may be needed on the End Cylinder. 550 psi is usually adequate but can be adjusted.
Maximizer #7 diaphragm wearing too quickly.	<ol style="list-style-type: none"> 1) Sharp Edge on lower front side of side pusher cross slide #5. 2) Too much air pressure to diaphragm. 3) Incorrect assembly of pneumatic shoe assembly. 	<ol style="list-style-type: none"> 1) Remove side pusher cross slide & break down sharp edge with file. 2) Air to Maximizer diaphragm should be between 35 & 40 PSI. 3) Properly Reassemble Maximizer.
End pusher #6 moves forward slowly, not squaring off belly, but most normally when press is empty. Grease turning black on top of press plate.	Stop press in closed position with press plate #1 fully extended to the left. Examine top of press plate for galling. If press plate is galled, mating area of bottom of cross slide will also be galled.	Remove cross slide and press plate assembly from press. Separate cross slide and press plate. Emery and Stone down high spots in galled area. Clean out all loose metal chips. Directly grease galled area every hour until blackening ceases.
Over-pressing. Belly tipping over end forming Bar #3.	Pressure Switch #11 set too high.	Lower closing pressure of pressure switch.



Get results.

**Waukesha
Cherry-Burrell**

611 SUGAR CREEK ROAD
DELAVAN, WI 53115 U.S.A.
CUSTOMER SERVICE TELEPHONE
1-800-252-5200 OR 262-728-1900
TOLL FREE TELEFAX
1-800-252-5012 OR 262-728-4904
E-mail: info@processequipment.spx.com
Web Site: www.spxpe.com