

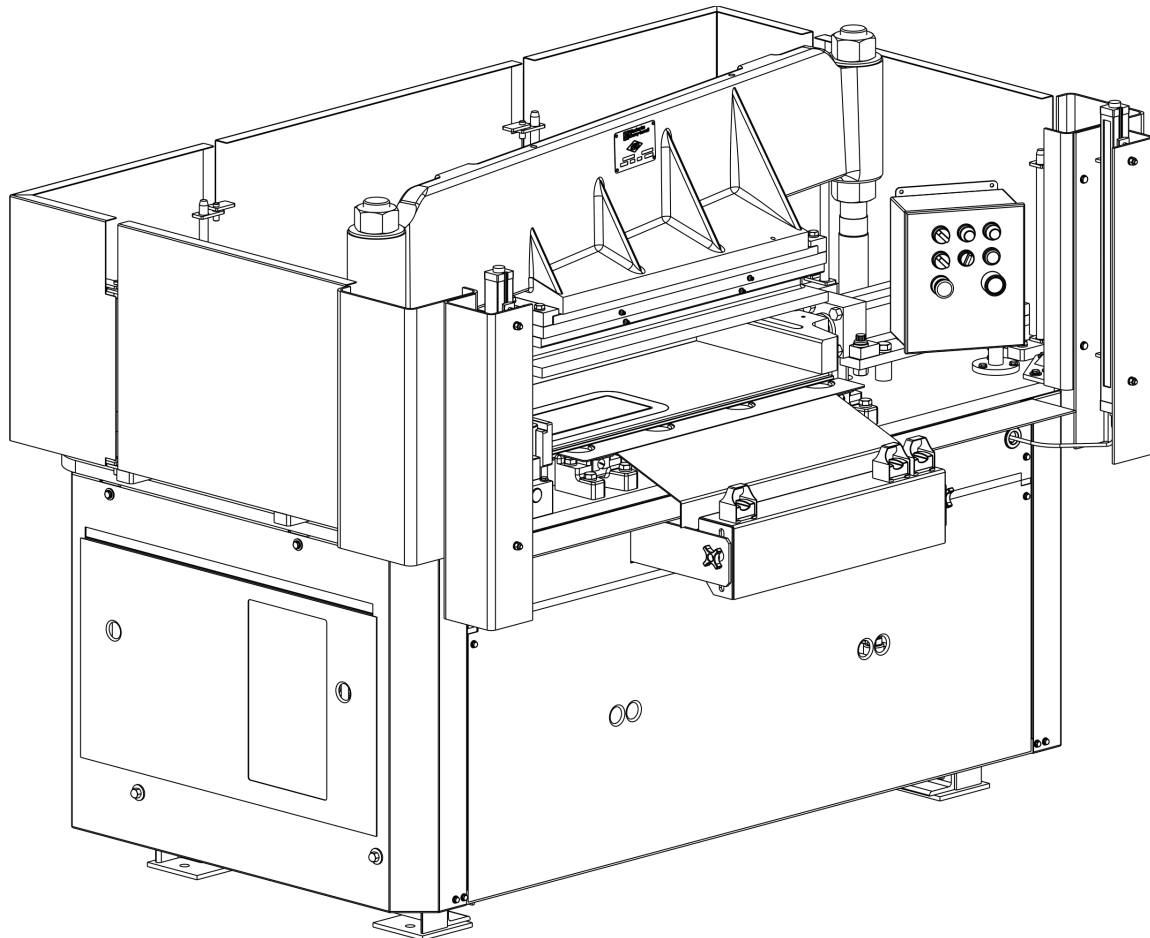

Operation and Maintenance Manual ANCO 1411P-G3 Bacon Forming Press with Optional Dual Width Control



Read and understand this manual
prior to installing, operating or servicing this equipment.



**Waukesha
Cherry-Burrell**

®

AN SPX BRAND

611 Sugar Creek Road
Delavan, WI 53115 USA

Tel.: 800.252.5200 (within the USA) • (262)728.1900
Fax: 800.252.5012 (within the USA) • (262)728.4904

E-mail: wcb@spx.com
Web site: www.spxpe.com

Information contained in this manual is subject to change without notice and does not represent a commitment on the part of SPX Corporation. No part of this manual may be reproduced or transmitted in any form or by any means, electronic or mechanical, including photocopying and recording, for any purpose, without the express written permission of SPX Corporation.

Copyright © 2008 SPX Corporation. All Rights Reserved.

Mobil is a registered trademark of Exxon Mobil Corporation.
Allen-Bradley is a registered trademark of Rockwell Automation.

Issued: **May 2006**

Publication: **95-03082**

Waukesha Cherry-Burrell Warranty4
 Shipping Damage or Loss4
 Warranty Claim4
Safety Light Curtain Warranty5
 Warranty and Service Information5
Safety6
Care of Stainless Steel8
 Stainless Steel Corrosion8
 Cleaning Stainless Steel8
 Elastomer Seal Replacement Following Passivation8
Introduction9
 Width Control Mechanism11
 Dual Width Control Mechanism11
 Maximizer Assembly12
 Safety Light Curtain12
 Sender and Receiver Units12
 Safety Relay12
 Unit Protection12
 Safety Magnetic Interlock Switch and Upper Interlock Guards12
 Emergency Stop Abort Cycle Open Press12
 Safety Cycle Start Switches12
Installation13
 Lifting and Moving Procedures13
 Press Set Up14
 Safety Light Curtain Installation15
 Verification Sequence15
Operation16
 Bacon Press Start Up16
 Manual Operation Sequence16
 Auto Operation Sequence17
 Hydraulic Valve Operation Sequence19
 Heaters in Electrical Panels20
 Maximizer20
 Maximizer Operating Instructions21
 Maximizer Maintenance21
Maintenance22
 Adjustments22
 Main System Relief Valve23
 Sequence Valves for Side & End Cylinders23
 Head Lock Pressure Switch23
 Solid State Relays24
 Cycle Timing24
 End Cylinder Relief Valve24
 End Cylinder Pressure Switch and End Cylinder Pressure Delay Timer24
 Left End Disappearing Bar Prox25
 Hydraulic Cylinder Cushions Adjustment25
 Replacing Cylinder Gland Packing26
 Removing the Gland26
 Installing The Gland26
Troubleshooting28

Waukesha Cherry-Burrell Warranty

Seller warrants its products to be free from defect in materials and workmanship for a period of one (1) year from the date of shipment. This warranty shall not apply to products which require repair or replacement due to normal wear and tear or to products which are subjected to accident, misuse or improper maintenance. This warranty extends only to the original Buyer. Products manufactured by others but furnished by Seller are exempted from this warranty and are limited to the original manufacturer's warranty.

Seller's sole obligation under this warranty shall be to repair or replace any products that Seller determines, in its discretion, to be defective. Seller reserves the right either to inspect the products in the field or to request their prepaid return to Seller. Seller shall not be responsible for any transportation charges, duty, taxes, freight, labor or other costs. The cost of removing and/or installing products which have been repaired or replaced shall be at Buyer's expense.

Seller expressly disclaims all other warranties, express or implied, including without limitation any warranty of merchantability of fitness for a particular purpose. The foregoing sets forth Seller's entire and exclusive liability, and Buyer's exclusive and sole remedy, for any claim of damages in connection with the sale of products. In no event shall Seller be liable for any special consequential incidental or indirect damages (including without limitation attorney's fees and expenses), nor shall Seller be liable for any loss of profit or material arising out of or relating to the sale or operation of the products based on contract, tort (including negligence), strict liability or otherwise.

Shipping Damage or Loss

If equipment is damaged or lost in transit, file a claim at once with the delivering carrier. The carrier has signed the Bill of Lading acknowledging that the shipment has been received from WCB in good condition. WCB is not responsible for the collection of claims or replacement of materials due to transit shortages or damages.

Warranty Claim

Warranty claims must have a **Returned Goods Authorization (RGA)** from the Seller before returns will be accepted.

Claims for shortages or other errors, exclusive of transit shortages or damages, must be made in writing to Seller within ten (10) days after delivery. Failure to give such notice shall constitute acceptance and waiver of all such claims by Buyer.

Safety Light Curtain Warranty

Warranty and Service Information

Waukesha Cherry-Burrell warrants that safety light curtain devices (Sender, Receiver and Safety Relay Interface) are free from defects in material and workmanship under normal use and service for a period of one year from date of shipment. WCB obligations under this warranty are limited to repairing or replacing, at its discretion and at its factory or facility, any products which shall, within the applicable period after shipment, be returned to WCB freight prepaid, and which are, after examination, disclosed to the satisfaction of WCB to be defective. This warranty shall not apply to any devices which have been subjected to improper installation, misuse, negligence or accident. The provisions of this warranty do not extend to the original warranty of any product which has been repaired or replaced by WCB, and no other warranty is expressed or implied. This warranty is limited to the quality of materials and workmanship in Allen-Bradley® devices as they are supplied to the original purchaser. Proper installation, maintenance and use becomes the sole responsibility of the user upon receipt of the device.

Ensure supervisors, maintenance personnel, machine operators and foreman have read and understand all instructions pertaining to the operation, use and testing of the Safety Light Curtain.

Ensure the Safety Light Curtain is tested and inspected daily as specified and outlined under “Safety Light Curtain Verification Sequence” and per manufacturer’s recommendations. Ensure the press operates only when the press and the Safety Light Curtain are both in proper working order.

Naturally, the enforcement of these requirements is beyond WCB’s ability to control. WCB does have available extra warning and test procedure labels. These are to be affixed to both Safety Light Curtain units, and serve to remind personnel of the proper usage and maintenance procedures. Please write to WCB if you require additional labels.

Allen-Bradley® manufactures the Safety Light Curtain units to meet stringent specifications, and cannot assume any responsibility for those consequences arising from their misuse. Infrared presence-sensing devices are designed and built to protect machine operators and passersby from inadvertent access to pinchpoint hazards. In order to obtain such protection, users must properly install, maintain and test their Safety Light Curtain units in accordance with this manual and the Allen-Bradley manual.

Safety

READ AND UNDERSTAND THIS MANUAL PRIOR TO INSTALLING, OPERATING OR SERVICING THIS EQUIPMENT

Waukesha Cherry-Burrell recommends users of our equipment and designs follow the latest Industrial Safety Standards. At a minimum, these should include the industrial safety requirements established by:

1. Occupational Safety and Health Administration (OSHA), Title 29 of the CFR
Section 910.212- General Requirements for all Machines
2. National Fire Protection Association, ANSI/NFPA 79
ANSI/NFPA 79- Electrical Standards for Industrial Machinery
3. National Electrical Code, ANSI/NFPA 70
ANSI/NFPA 70- National Electrical Code
ANSI/NFPA 70E- Electrical Safety Requirement for Employee Workplaces
4. American National Standards Institute, Section B11

Attention: Servicing energized industrial equipment can be hazardous. Severe injury or death can result from electrical shock, burn, or unintended actuation of controlled equipment. Recommended practice is to disconnect and lockout industrial equipment from power sources, and release stored energy, if present. Refer to the National Fire Protection Association Standard No. NFPA 70E, Part II and (as applicable) OSHA rules for Control of Hazardous Energy Sources (Lockout-Tagout) and OSHA Electrical Safety Related Work Practices, including procedural requirements for:

- Lockout-tagout
- Personnel qualifications and training requirements
- When it is not feasible to de-energize and lockout-tagout electrical circuits and equipment before working on or near exposed circuit parts

Locking and Interlocking Devices: These devices should be checked for proper working condition and capability of performing their intended functions. Make replacements only with the original manufacturer's renewal parts or kits. Adjust or repair in accordance with the manufacturer's instructions.

Periodic Inspection: Industrial equipment should be inspected periodically. Inspection intervals should be based on environmental and operating conditions and adjusted as indicated by experience. At a minimum, an initial inspection within 3 to 4 months after installation is recommended. Inspection of the electrical control systems should meet the recommendations as specified in the National Electrical Manufacturers Association (NEMA) Standard No. ICS.3, Preventative Maintenance of Industrial Control and Systems Equipment, for the general guidelines for setting-up a periodic maintenance program.

Replacement Equipment: Use only replacement parts and devices recommended by the manufacturer to maintain the integrity of the equipment. Make sure the parts are properly matched to the equipment series, model, serial number, and revision level of the equipment.

Warnings and cautions are provided in this manual to help avoid serious injury and/or possible damage to equipment:



DANGER: marked with a stop sign.

Immediate hazards which *WILL* result in severe personal injury or death.











WARNING: marked with a warning triangle.

Hazards or unsafe practices which *COULD* result in severe personal injury or death.

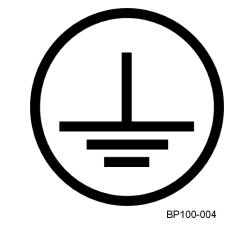

CAUTION: marked with a warning triangle.

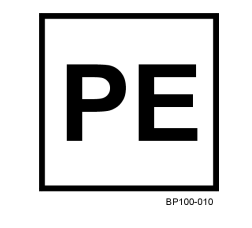
Hazards or unsafe practices which *COULD* result in minor personal injury or product or property damage.

| | |
|---|---|
|  <p>DANGER: Hazardous Voltage</p> <p>BP100-005</p> |  <p>WARNING: Hand Crush; Force from Above</p> <p>BP100-003</p> |
|  <p>WARNING: High Pressure Oil</p> <p>BP100-001</p> |  <p>WARNING: Hand Crush; Force from Side</p> <p>BP100-002</p> |
|  <p>WARNING: Hazardous Overhead Weight WARNING: Hazardous Moving Parts</p> <p>BP100-006</p> |  <p>CAUTION: Protective Earth (Ground)</p> <p>BP100-004</p> |
|  <p>WARNING: Do Not Operate with Guard Removed; Hazardous Moving Parts</p> <p>BP100-007</p> |  <p>CAUTION: Physical Earth (PE)</p> <p>BP100-010</p> |
|  <p>WARNING: Read and Understand Operation Manual</p> <p>BP100-008</p> | |

 **CAUTION:** Noise emission reaches maximum of 94.9 dB(A) as determined by factory testing. To protect personnel against damage from noise emission, wear suitable hearing protection devices.

Care of Stainless Steel

Stainless Steel Corrosion

Corrosion resistance is greatest when a layer of oxide film is formed on the surface of stainless steel. If film is disturbed or destroyed, stainless steel becomes much less resistant to corrosion and may rust, pit or crack.

Corrosion pitting, rusting and stress cracks may occur due to chemical attack. Use only cleaning chemicals specified by a reputable chemical manufacturer for use with 300-series stainless steel. Do not use excessive concentrations, temperatures or exposure times. Avoid contact with highly corrosive acids such as hydrofluoric, hydrochloric or sulfuric. Also avoid prolonged contact with chloride-containing chemicals, especially in presence of acid. If chlorine-based sanitizers are used, such as sodium hypochlorite (bleach), do not exceed concentrations of 50 ppm available chlorine, do not exceed contact time of 20 minutes, and do not exceed temperatures of 104°F (40°C).

Corrosion discoloration, deposits or pitting may occur under product deposits or under gaskets. Keep surfaces clean, including those under gaskets or in grooves or tight corners. Clean immediately after use. Do not allow equipment to set idle, exposed to air with accumulated foreign material on the surface.

Corrosion pitting may occur when stray electrical currents come in contact with moist stainless steel. Ensure all electrical devices connected to the equipment are correctly grounded.

Cleaning Stainless Steel

The most common and best approach to cleaning and sanitizing stainless steel is for a cleaning procedure to be developed by the plant sanitarian and a qualified representative of a reputable cleaning chemical supply company. Prior to processing, the plant sanitarian provides information on the “soil” (material to be cleaned away) and sanitizing requirements (killing of bacteria on equipment product contact surfaces). The chemical supply representative provides information on the chemical solutions (type, concentrations and temperature) best for cleaning away the soil, determines the needed degree of sanitizing and ensures the chemical solutions are suitable for use on stainless steel. For manual cleaning, use only soft, non-metallic brushes, sponges or pads. Brush with the grain on polished surfaces and avoid scratching to maintain appearance.



CAUTION: Thoroughly rinse all cleaning chemicals from stainless steel surfaces after cleaning. Chemical solutions in contact with stainless steel for long periods of time may cause corrosion and pitting.



CAUTION: Avoid direct contact spray cleaning of all electrical enclosures and distribution boxes.

During spray cleaning:

1. Keep bottom skirt components in place.
2. Do not remove distribution box splash covers.
3. Securely cover or remove operator panel and safety light curtains.

Elastomer Seal Replacement Following Passivation

Passivation chemicals can damage product contact areas of WCB equipment. Elastomers (rubber components) are most likely to be affected. Always inspect all elastomer seals after passivation is completed. Replace any seals showing signs of chemical attack. Indications may include swelling, cracks, loss of elasticity or any other noticeable changes when compared with new components.

Introduction

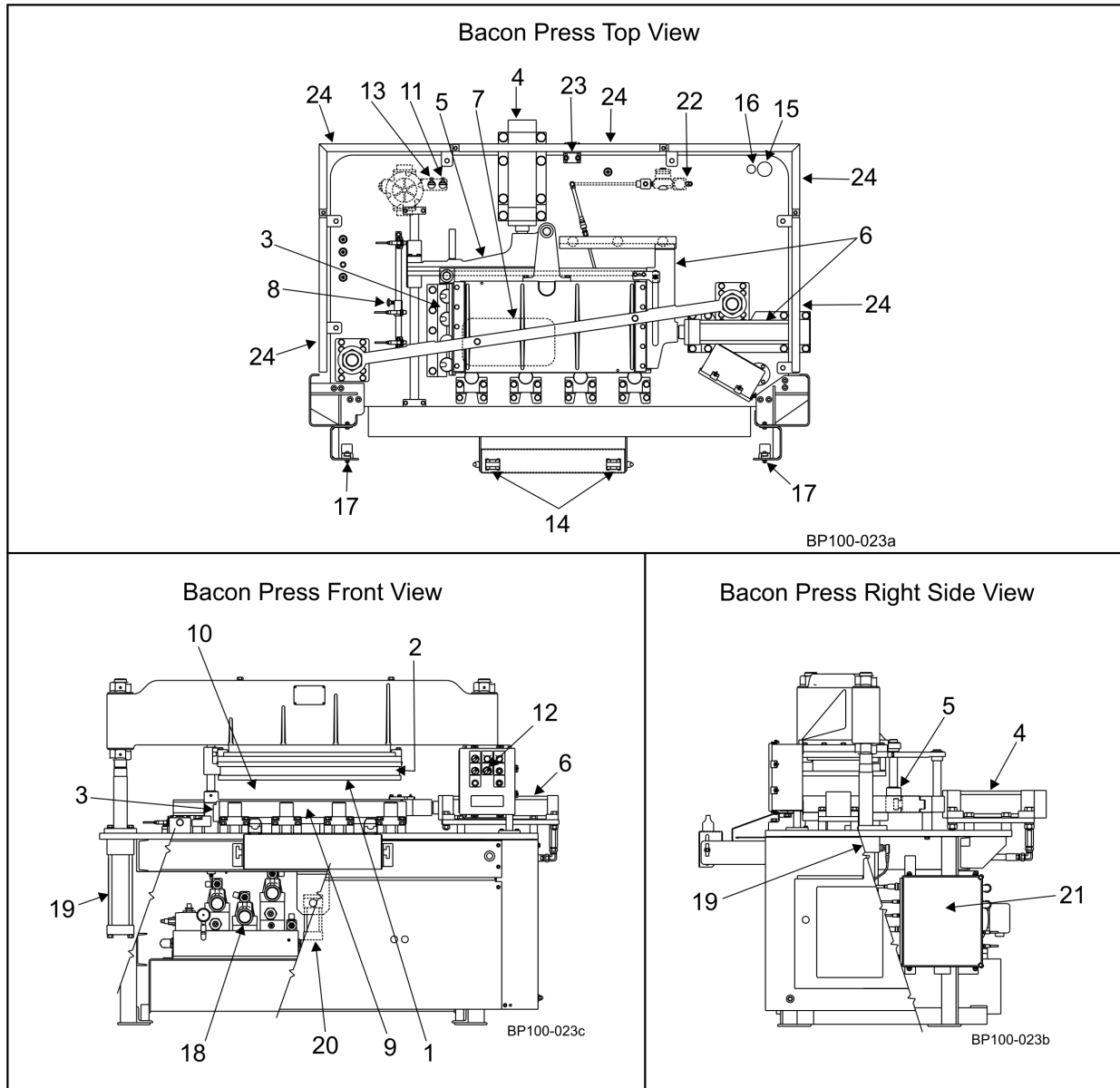

Figure 1 - Bacon Press Major Components

| Item # | Description |
|--------|-------------------------------|
| 1 | Top Press Plate |
| 2 | Cross Slide |
| 3 | Left End Disappearing Bar |
| 4 | Side Cylinder |
| 5 | Side Cylinder Pusher |
| 6 | End Cylinder and Pusher |
| 7 | Maximizer |
| 8 | Width Control Assembly |
| 9 | Front Disappearing Bar |
| 10 | Die Box |
| 11 | Pressure Switch - End Forming |
| 12 | Operator Push Button Panel |
| 13 | Pressure Switch - Head Lock |

| Item # | Description |
|--------|--|
| 14 | Cycle Start Switches |
| 15 | 2-9/16" Dia. Electrical Terminal Box Conduit Feed Hole |
| 16 | 1-1/2" Dia. Electrical Hydraulic Motor Conduit Feed Hole |
| 17 | Safety Light Curtain |
| 18 | Hydraulic Power Unit |
| 19 | Head Up/Down Cylinders |
| 20 | Front Disappearing Bar Cylinder |
| 21 | Terminal Box |
| 22 | 1/4" FNPT Maximizer Air Supply Connection |
| 23 | Magnetic Interlock Guard Switch |
| 24 | Interlocking Guards |

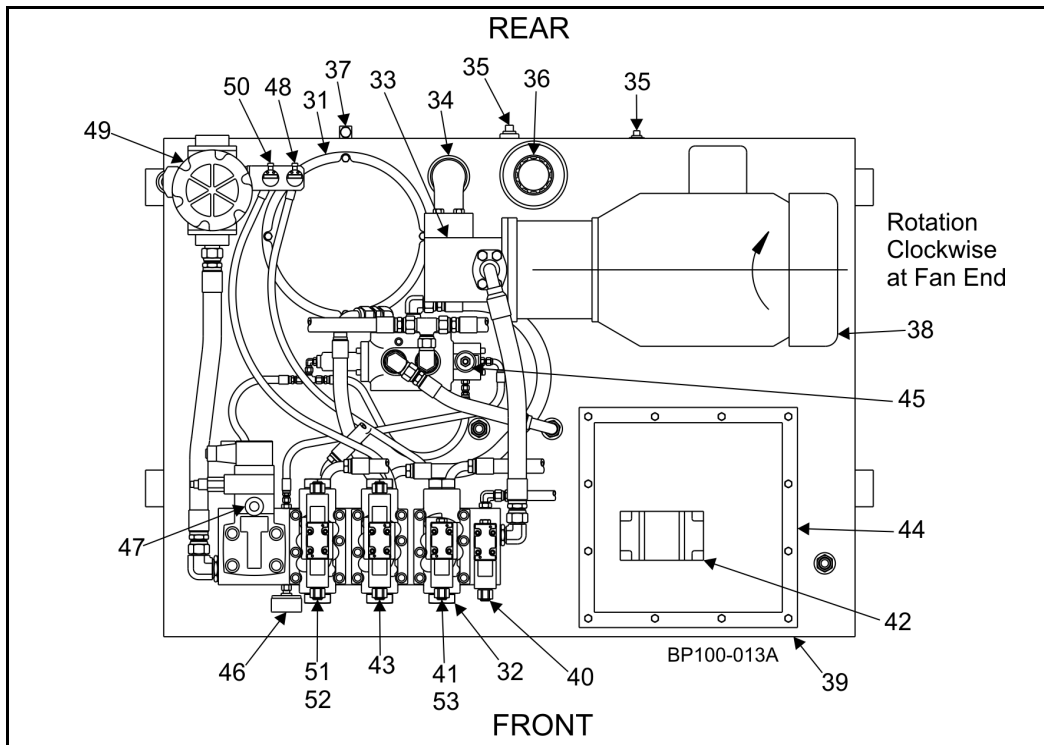

Figure 2 - Hydraulic Power Unit

| Item # | Description |
|--------|---|
| 31 | Clean Out Port |
| 32 | End Relief Valve (Located under Valve) |
| 33 | Hydraulic Pump |
| 34 | Oil Suction |
| 35 | Oil Drain Plug |
| 36 | Oil Fill / Desiccant Type Breather |
| 37 | Sight Level Gauge with Thermometer |
| 38 | Electric Motor |
| 39 | Tank |
| 40 | Front Bar Directional Control Valve |
| 41 | End Cylinder Directional Control Valve |
| 42 | Flow Divider |
| 43 | Head Up/Down Directional Control Valve |
| 44 | Tank Access Cover |
| 45 | Head Lock Valve |
| 46 | Pressure Gauge |
| 47 | Main Relief Valve |
| 48 | Pressure Sensor Switch - End Forming |
| 49 | Return Filter |
| 50 | Pressure Sensor Switch - Head Lock |
| 51 | Side Cylinder Directional Control Valve |
| 52 | Sequence Valve (located under side valve) |
| 53 | Sequence Valve (located under end valve) |

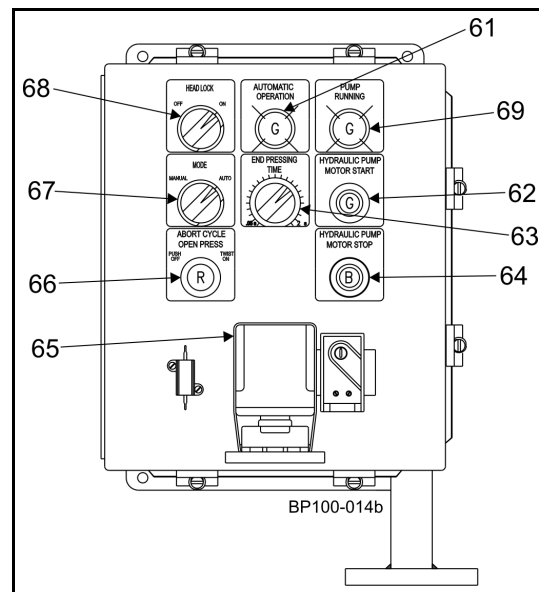

Figure 3 - Operator Push Button Panel

| Item # | Description |
|--------|--|
| 61 | Automatic Operation Pilot Light |
| 62 | Hydraulic Pump Motor Start Push Button |
| 63 | End Pressing Time |
| 64 | Hydraulic Pump Motor Stop Push Button |
| 65 | Time Delay Relay |
| 66 | E-Stop Abort Cycle, Open Press Push Button |
| 67 | Manual/Auto Mode Selector Switch |
| 68 | Head Lock Selector Switch |
| 69 | Hydraulic Pump Operation Light |

CAUTION: Instructions should be carefully reviewed and understood by all personnel involved in operating, maintaining, and testing equipment.

Width Control Mechanism

The width control mechanism (Figure 1, item 8), located on left side of press table top, assists operator in determining finished width of pressed belly. Setting is 7 to 14 inches, subject to limitations imposed by varying characteristics of product (such as temperature, type of feed in fattening hog, etc.). Limitations determine the total amount a belly can be compressed without cracking. Field testing on grain-fed bellies at 24°F to 28°F indicates a belly may be compressed approximately 20% smaller than its maximum unpressed width. After natural spring-back, the result is approximately 10% permanent width reduction, squared for slicing.

To set width, loosen knob (Figure 4, item 74) and move standard width switch (PX6) (item 71) along slide plate (item 75) to desired setting. Item 72 proximity switch indicates home position. Item 73 proximity switch indicates eject position.

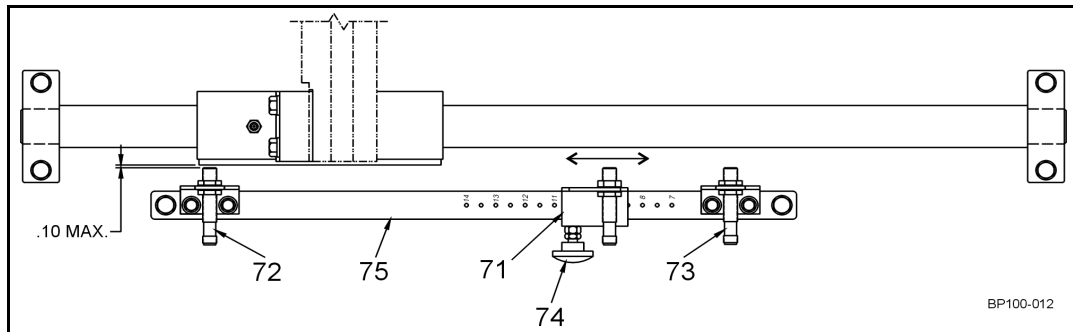

Figure 4 - Width Control Mechanism

Dual Width Control Mechanism

By adding a third cycle start switch as shown in

6, dual width control option allows operator to grade bacon width during processing for two different sizes.

Narrow Belly Pressing

1. Use the left cycle start switch along with right “narrow width” cycle start switch.
2. To set narrow width, loosen knob (Figure 5, item 81) and move narrow width switch (PX5) (item 83) along slide plate (item 75) to desired setting.

Wide Belly Pressing

1. Use the left cycle start switch along with the right “wide width” cycle start switch.
2. To set wide width, loosen wide width switch (PX6) (item 82) and move to desired distance from narrow width switch on bracket.

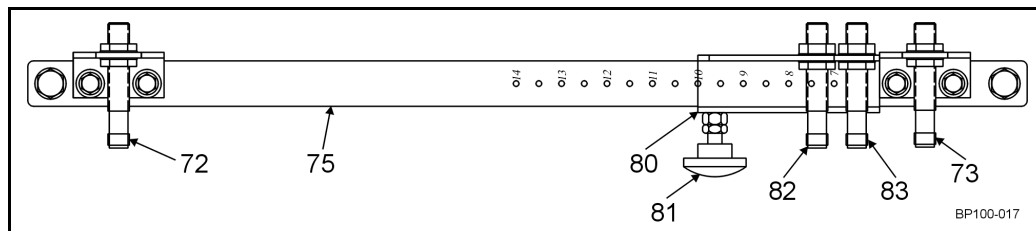

Figure 5 - Optional Dual Width Control Mechanism

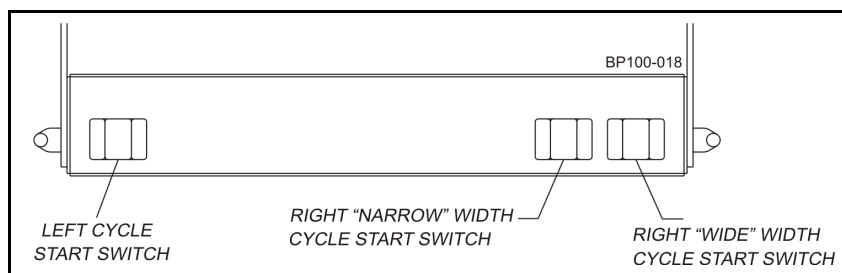

Figure 6 - Cycle Start Switches for Dual Width Control Operation

Maximizer Assembly

The 1411P-G3 Press Maximizer assembly (Figure 1, item 7) is located in bottom of die box. Maximizer inflates (SOL-1) to provide a smooth yielding contour for bacon to flow over during pressing operation. At final phase of operation, pressure developed above bacon overcomes pressure in Maximizer diaphragm, allowing bottom of bacon to flatten out and minimize wrinkles in most bellies.



NOTE: *Maximizer diaphragm replacement is recommended after 350 hours of operation or one month, whichever occurs first, or whenever Maximizer diaphragm becomes deformed.*

Safety Light Curtain

The safety light curtain (Figure 1, item 17) prevents press operation from starting or returns press to open position if operator interrupts safety light curtain before or during press operation. At the beginning of each shift, test and verify safety light curtain. For related information refer to Allen-Bradley User Manual provided.

Sender and Receiver Units

The infrared safety light curtain consists of two separate units, one sender and one receiver. The units provide an invisible infrared light curtain across front of press.

Power (24VDC) must be supplied to each safety light curtain unit. Power and operation status are indicated by indicators on each unit. Sender and receiver units must be properly aligned for press to operate. The receiver orange indicator illuminates any time light field is not consistent between the two units.



NOTE: *During cleanup, sender and receiver units should be securely covered.*

Safety Relay

Located in remote control panel is the monitoring safety relay for safety light curtain sender and receiver units. This relay monitors status and provides final safety stop circuit.

Unit Protection

Always cover and protect safety light curtain units during press cleaning operations. Do not immerse or direct high pressure water or cleaning streams on safety light curtain units.

Unit Window Cleaning

Clean safety light curtain sender and receiver windows using a clean, soft, damp cloth. Avoid excessive rubbing.

Safety Magnetic Interlock Switch and Upper Interlock Guards

Safety magnetic interlock switch (Figure 1, item 23) is made up of a switch and actuator. Switch is mounted to top of table and actuator is mounted to back guard. All guards on top of table are interconnected to each other with switch actuator mounted onto back guard. Switch and actuator must be in contact for press operation. When guards are open or removed, switch and actuator are interrupted preventing press operation. At the beginning of each shift, test and verify switch is operational, and insure upper interlock guards (Figure 1, item 24) are in place above table top at both sides and at back of press.

Emergency Stop Abort Cycle Open Press

1. In emergency, push in red abort cycle push button (Figure 3, item 66) located on operator push button panel.
2. Pull and twist push button releasing outward to make press operational again.

Safety Cycle Start Switches

Safety cycle start switches (Figure 1, item 14) are used to start press by simultaneously placing and holding both hands on left and right safety start touch switches.

- In manual mode, press remains closed and pressing until operator releases left or right hand safety start switches.
- In auto mode, operator may release left or right hand safety start switches when auto indicator illuminates.

Installation

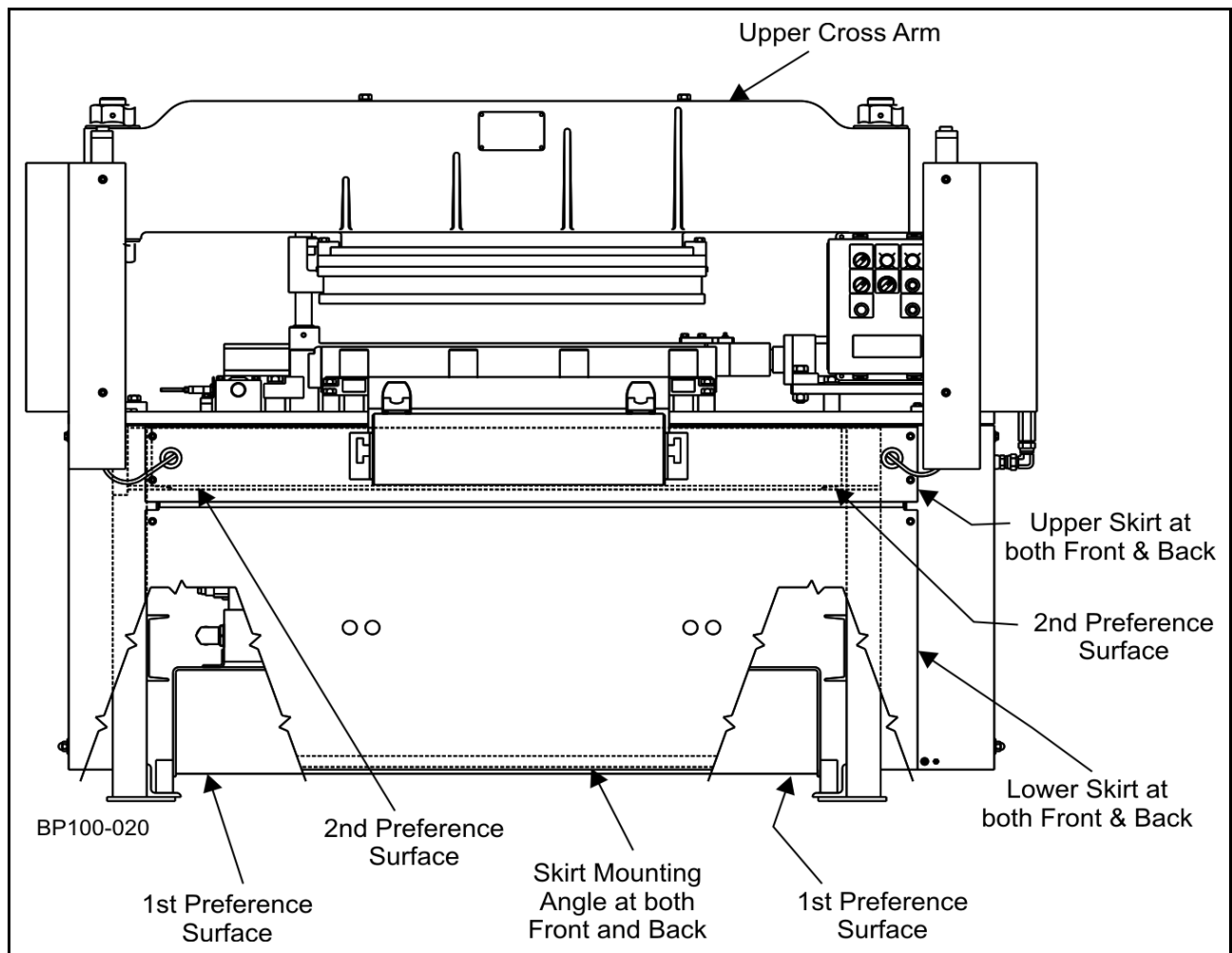

Figure 7 How to Lift When in Field

Lifting and Moving Procedures

Remove both front and back lower skirts and be careful to avoid possible contact that may damage either front or back skirt mounting angles.

! ***CAUTION:** Never use upper cross arm for lifting or moving the bacon press. Use extreme care during lifting and moving to prevent dropping of the bacon press.*

Use the following surfaces to lift or move the bacon press:

1st Preference: Surfaces that provide good support, but care must be taken to insure that lift forks are kept spread out for contact at the extreme edges near the press legs. This is where the hydraulic tank is the most structurally sound for lifting. Placing the lift forks away from these edges may abnormally affect components that are inside the hydraulic tank.

2nd Preference: Surfaces that provide good support, but removal of the upper front and back skirts are required. Be extremely cautious of any components under the table top that may interfere.

Remove the bacon press from its skid and place in the plant location that has been selected.

Press Set Up

If unfamiliar with press, contact a WCB Service Technician at (800) 252-5200 (U.S. only) or (262) 728-1900 to assist in initial start up, commissioning and training.

The 1411P-G3 Bacon Press consists of press and remote control panel. Press is fully pre-wired, tested and run at factory. Remote control panel contains customer point for power connection, power supply, interface relays, hydraulic pump motor starter with overload module, Allen-Bradley® PLC, terminal blocks and fuses. Remote control panel is mounted near press, and power wiring, control wiring and two conduits are installed from remote control panel to press. Remote control panel is provided with a power disconnect switch.

Electrical must be supplied to remote control panel. Refer to nameplate on upper cross arm of press for electrical requirements. From remote control panel, power wiring uses high voltage going to electrical motor for hydraulic pump and control wiring has all 24VDC going into terminal box.

Front of Bacon Press where safety light curtain is mounted is the area for loading and removal of bacon belly. Leave adequate operator space at front and around the remaining three sides for maintenance.

 **NOTE:** Customer provides mounting and wiring hardware and installation per the NEC and local governing authorities.

1. Set press in place.
2. Level table top by shimming under table legs. Securely bolt foot pads to floor to prevent press from walking or bouncing during operation. Table top level should be checked regularly (after 12 operating hours) until all settling is complete (approximately 8 weeks).

 **CAUTION:** Lack of proper table top leveling will cause twisting of table top, pistons to bind and structural members to break.

3. Connect control wiring from remote control panel to right side terminal box, and power wiring to hydraulic motor. Refer to WCB General Assembly and Electrical Schematics provided.

 **NOTE:** Run motor power wiring and 24VDC wiring in two separate conduits.



WARNING: To reduce electrical hazard to personnel and equipment, install a separate ground on hydraulic electrical motor. Terminate motor ground at remote control panel ground bar. All materials, installation, and workmanship should comply with the NEC and local governing authorities.

4. After completing hydraulic electrical motor power wiring, check motor rotation by jogging motor from “Stop/Start” control push buttons (PB1 & PB2) located on operator box (OP1).
5. Proper motor rotation is clockwise, looking from fan end of motor. If rotation is incorrect, reverse two power leads and recheck.



CAUTION: Hydraulic pump will not pump or build pressure if rotated in counter-clockwise direction. Pump damage will occur if operated in wrong direction.

6. If hydraulic pressure develops and head cylinders do not raise within 10 seconds, stop motor and check fluid level, suction strainer and suction piping. Inspect for loose joints or loose seals where air may be sucked in, and for foreign material blocking suction strainer and inlet from hydraulic reservoir.



WARNING: To prevent personnel injury during maintenance, cleaning, etc., always block cylinder head in position when raised. Remove all blocking materials before resuming press operations.

7. Start hydraulic electrical motor to open press. Stop when open. Lubricate grease fittings with a pressure gun using #2 food-grade grease. Grease fittings on intermediate cross slide of head should be excessively lubricated every four hours during run-in period. Wipe clean all die box parts.
8. With press in manual mode, begin press cycle and manually stop hydraulic motor with all three cylinders fully extended. Top front of cross slide and top left of top press plate will be exposed. Inspect and clean exposed areas for dirt, grit and foreign materials. Apply generous coat of #2 food-grade grease to exposed areas.
9. After washing and cleaning press, blow off excess water and lubricate all surfaces to minimize premature wear.
10. Press is designed to operate at 25°F to 65°F ambient temperature. Hydraulic power pack filled with Mobil DTE-25 (ISO#46) hydraulic fluid is provided. If lower ambient temperature exists, use a tank heater to hold minimum hydraulic fluid temperature above 25°F.

11. Check hydraulic fluid level in hydraulic reservoir daily. Level must be maintained at top of sight glass tube. Sight gauge with thermometer is located on back of hydraulic reservoir.
12. Check desiccant type breather on top of hydraulic reservoir in back of press daily. When silica gel changes color from blue to pink, breather is no longer active and needs to be replaced.
13. Shortly after start up each day, check return oil filter located on top of hydraulic reservoir in back of press. When filter gauge reads “needs cleaning” or approaches bypass, filter element should be replaced.
14. For related information, refer to Ritter Technology Instruction and Service Manual provided.



CAUTION: Typically, loss of hydraulic fluid level indicates leakage somewhere on press. Timely and appropriate corrective action should be taken before equipment damage occurs.



CAUTION: Keep fluid level filled to top of high level mark. Filter hydraulic fluid with 10 micron filter before adding to reservoir.

Safety Light Curtain Installation

1. Align safety light curtain by slightly adjusting each unit on vertical and horizontal axis.
2. Keeping units in alignment, tighten brackets.

Please refer to the Allen-Bradley® user manual provided for further information on the Safety Light Curtain.

Verification Sequence

1. Power (24VDC) is applied to sender and receiver units from light curtain safety relay module located in remote control panel. Main disconnect switch must be in the “on” position.
2. Interrupt sensing field on receiver by passing a test bar from top to bottom of receiver face. Receiver red indicator should stay illuminated while bar is present anywhere in sensing field.
3. Interrupt sensing field on sender by passing a test bar from top to bottom of sender face. Receiver red indicator should stay illuminated while bar is present anywhere in sensing field.
4. When safety light curtain is interrupted, press should stay at idle and open position and cycle cannot begin. If press is in cycle, return to idle and open.

Operation

Bacon Press Start Up

 **WARNING:** To avoid injury from electrical shock, inspect and verify Bacon Press is properly and securely grounded.

Each day before operating press:

1. Lubricate grease fittings located on head sliding system, front bar and end bars. Lubricate fittings every eight hours of production.
2. Rub grease on all sliding components of press mechanism and on back retractor pins running through bearing.
3. Lubricate top edge of front bar and left end disappearing bar to avoid scratching bars or underside of top plate.

 **CAUTION:** Do not operate press if hydraulic oil temperature in reservoir is above 160°F.

4. Start press using hydraulic pump motor start push button (PB2) located on operator panel (See Figure 3, page 10, item 62). Push button starts hydraulic pump motor and allows electrical power (24VDC) to control circuits. Press will remain in idle and open position. Both head cylinders should be fully extended in up position.

Start Up: WCB recommends running hydraulic pump for a minimum of 45 minutes before operating press, particularly in colder equipment production areas to warm hydraulic fluid.

Manual Operation Sequence

Terms and Definitions

Side - bacon side formed, sized and pressed by side forming cylinder at rear of press

End – bacon end formed, pressed and squared by end forming cylinder at right side of press.

1. Ensure selector switch (SS1) (Figure 3, item 67) is in manual mode.
2. Place pork belly in die box. (Figure 1, item 10)
3. Simultaneously place hands on right and left hand start touch pads (PX1 & PX2 or PX3) (Figure 6) and hold will energize the following:
 - a Main relief solenoid valve (SOL-4) energizes and hydraulic pressure develops.
 - b Front disappearing bar solenoid valve (SOL-3) energizes and extends front bar upward.
 - c Head unlock solenoid valve (SOL-7) energizes and unlocks head cylinders.

4. With Head Lock off, solenoid valve (SOL-3) starts timer delay in program activating head down cylinder solenoid valve (SOL-2) energizes and retracts head cylinders. Head contacts front and left end disappearing bars energizing prox switch (PX4) located under table. Head makes full contact with belly and press is now closed. Head remains in place during side and end pressing but slightly floats upward during final end pressing of cycle.

5. Prox switch (PX4) will energize the following:
 - a Maximizer solenoid valve (SOL-1) and inflates maximizer.
 - b Extend side cylinder solenoid valve (SOL-6) extends to rear of die box pressing belly to desired width setting prox switch and de-energizes extend side cylinder solenoid valve (SOL-6) and locking cylinder in place. Width is set by operator and detected by width prox switch (PX5 or PX6). Press has adjustable scale to set bacon width (Figure 1, item 8).

 **NOTE:** If width control setting is too narrow, belly may crack or extrude over top of front disappearing bar. It is NOT recommended to press a belly more than once.

 **NOTE:** Dual width models have optional width optical touch switch (PX3) and second width prox switch (PX5).

6. Width prox switch (PX5 or PX6) energizes end cylinder solenoid valve (SOL-9) and end cylinder moves right side of die box inward to square ends of belly. Auto indicator (PL1) will illuminate when end cylinder pressure switch (PS1) energizes indicating end cylinder pressure is achieved.

 **NOTE:** Auto indication is an operator aid only; no press functions are controlled.

7. Maximum end cylinder pressure is set by end cylinder pressure relief valve on hydraulic power unit. Press should be closed, applying pressure and squaring bacon slab ends.

 **NOTE:** In manual, operator controls extent to which a belly is squared. Press remains closed and pressing until operator releases left or right hand start touch pads.

8. Upon release of right or left hand start touch pads will de-energizes the following:
 - a End cylinder solenoid valve (SOL-9) causing cylinder to fully retract.
 - b Head down solenoid valve (SOL-2) causing head cylinders to slightly raise opening die box.
 - c Maximizer solenoid valve (SOL-1) and deflates maximizer.
 - d Front disappearing bar solenoid valve (SOL-3) causing front disappearing bar to retract and energizing prox switch (PX11).
9. Prox switch (PX11) energizes extend side cylinder solenoid valve (SOL-6) to eject finished belly and prox switch (PX9) is energized.



NOTE: Interrupting safety curtain Figure 1, item 17) will automatically de-energize press cycle and open press to idle and open position. Press DOES NOT eject belly.

10. Prox switch (PX9) will energizes the following:
 - a Retract side cylinder solenoid valve (SOL-8) returning side cylinder to fully retracted position and energizes prox switch (PX10).
 - b Extend up head cylinder solenoid valve (SOL-5) causing head cylinders return to fully extended position, energizes prox switches (PX7 and PX8) in each head cylinder and fully opens die box.
11. Prox switches (PX7, PX8 & PX10) will de-energizes the following:
 - a Head unlock solenoid valve (SOL-7), locking head cylinders in upward position.
 - b Head up cylinder solenoid valve (SOL-5).
 - c Side cylinder solenoid valve (SOL-8).
 - d Main relief solenoid valve (SOL-4), venting hydraulic fluid into tank.
12. Press is now at idle, open and ready for next cycle.

Auto Operation Sequence

Terms and Definitions

Side – bacon side formed, sized and pressed by side forming cylinder at rear of press.

End – bacon end formed, pressed and squared by end forming cylinder at right side of press.

1. Ensure selector switch (SS1) (Figure 3, item 67) is in auto mode.
2. Place pork belly in die box. (Figure 1, item 10)
3. Simultaneously place hands on right and left hand start touch pads (PX1 & PX2 or PX3) (Figure 1, item 14) and hold will energize the following:
 - a Main relief solenoid valve (SOL-4) energizes and hydraulic pressure develops.
 - b Front disappearing bar solenoid valve (SOL-3) energizes and extends front bar upward.
 - c Head unlock solenoid valve (SOL-7) energizes and unlocks head cylinders.
4. With Head Lock off, solenoid valve (SOL-3) starts timer delay in program activating head down cylinder solenoid valve (SOL-2) energizes and retracts head cylinders. Head contacts front and left end disappearing bars energizing prox switch (PX4) located under table. Head makes full contact with belly and press is now closed. Release hands from right and left hand start touch pads when auto indicator (PL1) illuminates. Head remains in place during side and end pressing but slightly floats upward during final end pressing of cycle.

OR
5. With Head Lock on, solenoid valve (SOL-3) starts timer delay in program activating head down cylinder solenoid valve (SOL-2) energizes and retracts head cylinders. Head contacts front and left end disappearing bars energizing prox switch (PX4) located under table. Head pressure reaches set point of headlock pressure switch (PS2) Figure 2, item 50) de-energizing head unlock solenoid valve (SOL-7) and locking head cylinders in position. Pressure set point is determined by field factors and customer requirements. Press is now closed. Release hands from right and left hand start touch pads when auto indicator (PL1) illuminates. Head remains locked in place during side and end pressing.

6. Prox switch (PX4) will energize the following:
- Maximizer solenoid valve (SOL-1) and inflates maximizer.
 - Extend side cylinder solenoid valve (SOL-6) extends to rear of die box pressing belly to desired width setting prox switch and de-energizes extend side cylinder solenoid valve (SOL-6) and locking cylinder in place. Width is set by operator and detected by width prox switch (PX5 or PX6). Press has adjustable scale to set bacon width (See Figure 1, page 9, item 8).

 **NOTE:** If width control setting is too narrow, belly may crack or extrude over top of front disappearing bar. It is NOT recommended to press a belly more than once.

 **NOTE:** Dual width models have optional width optical touch switch (PX3) and second width prox switch (PX5).

7. Width prox switch (PX5 or PX6) energizes end cylinder solenoid valve (SOL-9) and end cylinder moves right side of die box inward to square ends of belly.
8. In auto, end squaring is a function of pressure and time. First, end cylinder extends and meets bacon end. Cylinder pressure builds and end cylinder pressure switch (PS1) (Figure 2, item 48) energizes at set point. Pressure set point is determined by field factors and customer requirements. Second, end cylinder pressure delay timer (TDR-1) is energized by end cylinder pressure switch (PS1). Relay time base is adjusted by end cylinder timer pot (POT-1) (See Figure 3, page 10, item 63) located on front of operator panel (OP-1). Pot adjustment provides approximate timing range of 0.06 to 2.00 seconds. Therefore, end cylinder pressure switch energizes, timer starts, completes and energizes input (I-15).

 **NOTE:** End cylinder pressure switch only activates timer in auto mode. No press actions occur due to pressure switch activation. Press action occurs only in auto after end pressure time delay contact energizes input.

 **NOTE:** End cylinder maximum pressure is limited by end pressure relief valve on hydraulic power unit.

 **NOTE:** In auto, pressure/time base (PS1 and TDR-1 w/POT-1) controls extent to which a belly is squared. Press remains closed and pressing until end cylinder pressure delay contact energizes input (I-15).

9. When end cylinder pressure delay contact energizes input, the following happens:
- Head unlock solenoid valve (SOL-7) energizes and unlocks head cylinders, only if head lock selector switch (SS3) is turned on.
 - End cylinder solenoid valve (SOL-9) de-energizes causing cylinder to fully retract.
 - Head down solenoid valve (SOL-2) de-energizes causing head cylinders to slightly raise opening die box.
 - Maximizer solenoid valve (SOL-1) de-energizes causing maximizer to deflate.
 - Front disappearing bar solenoid valve (SOL-3) de-energizes causing front disappearing bar to retract and energizing prox switch (PX11).
10. Prox switch (PX11) energizes extend side cylinder solenoid valve (SOL-6) to eject finished belly and prox switch (PX9) is energized.

 **NOTE:** Interrupting safety curtain (Figure 1, item 17) will automatically de-energize press cycle and open press to idle and open position. Press DOES NOT eject belly.

11. Prox switch (PX9) will energizes the following:
- Retract side cylinder solenoid valve (SOL-8) returning side cylinder to fully retracted position and energizes prox switch (PX10).
 - Extend up head cylinder solenoid valve (SOL-5) causing head cylinders return to fully extended position, energizes prox switches (PX7 and PX8) in each head cylinder and fully opens die box.
12. Prox switches (PX7, PX8 & PX10) will de-energizes the following:
- Head unlock solenoid valve (SOL-7), locking head cylinders in upward position.
 - Head up cylinder solenoid valve (SOL-5).
 - Side cylinder solenoid valve (SOL-8).
 - Main relief solenoid valve (SOL-4), venting hydraulic fluid into tank.
13. Press is now at idle, open and ready for next cycle.

Hydraulic Valve Operation Sequence***Terms and Definitions***

Side – bacon side formed, sized and pressed by side forming cylinder at rear of press.

End – bacon end formed, pressed and squared by end forming cylinder at right side of press.

1. Start hydraulic pump motor (MTR1) by pressing hydraulic pump motor start push button (PB2) Figure 3, item 62). Hydraulic pump operation light (PL2) Figure 3, item 69) will illuminate when pump is running. Hydraulic pump delivers hydraulic oil through valve manifold, through main relief valve (SOL-4) and into tank. Although main relief valve is in vent position (output SOL-4 de-energized), back pressure (approximately 20 to 40 psig) will typically exist.
 2. Ensure press is idle and open with all cylinders retracted, head cylinders fully extended and die box open.
 3. When left and right hand start touch pads (PX1 & PX2 or PX3) (Figure 1, item 14) are energized, the following happens:
 - a Main relief solenoid valve (SOL-4) energizes and moves to pressure control position. Typically, operating pressure is factory set for approximately 600 to 750 psig but may require adjusting during start up and commissioning.
 - b Front bar up solenoid valve (SOL-3) energizes and hydraulic oil flows through extending front bar upward.
 - c Head unlock solenoid valve (SOL-7) energizes and unlocks head cylinders.
 4. Solenoid valve (SOL-3) starts timer delay in program energizing head down cylinder solenoid valve (SOL-2). Hydraulic oil flows through head down directional valve, through head unlock valve, through flow divider and into head cylinder rod ends. Head cylinders retract until stopped by belly resistance or by head lock pressure switch. According to head lock program sequence, if head lock selector switch (SS3) is on, head lock pressure switch (PS2) (Figure 2, item 50) will energize when head oil pressure reaches set point of head lock pressure switch due to belly resistance. This will switch head unlock valve to closed position and will trap oil in both rod and cylinder end of head cylinders, locking head in place.
5. Prox switch (PX4) is activated by the head coming down and energizes extend side cylinder solenoid valve (SOL-6). Hydraulic oil flows through side cylinder directional valve extending and moving side cylinder to belly width energizing prox switch (PX6 or PX5). Prox switch (PX6 or PX5) de-energizes extend side cylinder solenoid valve (SOL-6) stopping and locking side cylinder in position.
 6. Prox switch (PX6 or PX5) energizes end cylinder solenoid valve (SOL-9). Hydraulic oil flows through end cylinder directional valve extending and squaring belly slab ends.
 7. Press cycle functions will differ depending on manual or auto selection (SS1).
 - a In manual, end cylinder will press and square belly until operator releases left or right hand start touch pads (PX1 & PX2 or PX3) (Figure 1, item 14).
 - b In auto, end cylinder will press and square belly determined by pressure and time (end cylinder pressure switch (PS1) (Figure 2, item 48) and end cylinder pressure delay timer (TDR-1) (Figure 3, item 63).
 8. In manual or auto mode, maximum pressing force of end cylinder is set by end cylinder relief valve. Factory setting is approximately 450 psig but may be readjusted during start up and commissioning. End cylinder stops extending when end cylinder pressure equals end cylinder relief valve set point. When this occurs, hydraulic oil flows through end cylinder relief valve into tank.
 9. End cylinder pressure switch (PS1) (Figure 2, item 48) is factory set slightly lower than end cylinder relief valve setting to insure sufficient pressure available to operate pressure switch. End cylinder pressure switch (PS1) is readjusted at start up and commissioning.



NOTE: Head lock selector switch (SS3) is hard-wired in series with PLC output (SOL-7) and head lock solenoid valve. PLC program runs requirement and energizes output (SOL-7). However, position of head lock selector switch (SS3 on or off) determines if solenoid is actually energized.

10. Upon releasing left or right hand start touch pads (PX1 & PX2 or PX3) (Figure 1, item 14) in manual or by end cylinder pressure delay contact (input I/15) in auto, the following happens:
 - a Head unlock solenoid valve (SOL-7) energizes and unlocks head cylinders.
 - b Head down solenoid valve (SOL-2) de-energizes putting hydraulic directional valve in neutral position causing hydraulic oil to pressurize head cylinders to slightly raise and open die box.
 - c End cylinder solenoid valve (SOL-9) de-energizes shifting directional valve causing hydraulic oil to reverse flow retracting end cylinder fully.
 - d Maximizer solenoid valve (SOL-1) de-energizes causing maximizer to deflate.
 - e Front disappearing bar solenoid valve (SOL-3) de-energizes shifting directional valve causing hydraulic oil to reverse flow lowering front disappearing bar energizing prox switch (PX11).
11. Prox switch (PX11) energizes extend side cylinder solenoid valve (SOL-6), shifting side cylinder directional valve causing hydraulic oil to flow and eject finished belly energizing prox switch (PX9).
12. Prox switch (PX9) will energizes the following:
 - a Side cylinder solenoid valve (SOL-8), shifting side cylinder directional valve causing hydraulic oil to flow and return side cylinder to fully retracted position energizing prox switch (PX10).
 - b Head up cylinder solenoid valve (SOL-5), shifting head cylinder directional valve causing hydraulic oil to flow and raising head cylinders to fully extended position energizing prox switches (PX7 and PX8) in each head cylinder and fully opens die box.
13. Prox switches (PX7, PX8 & PX10) will de-energizes the following:
 - a Head unlock solenoid valve (SOL-7), locking head cylinders in upward position.
 - b Head up cylinder solenoid valve (SOL-5).
 - c Side cylinder solenoid valve (SOL-8).
 - d Main relief solenoid valve (SOL-4), venting hydraulic fluid into tank.
14. Press is now at idle, open and ready for next cycle.



NOTE: At press start up and commissioning, press cycle times of approximately five to six seconds are normal. After break-in period, a four to five second cycle time is typical.



CAUTION: If any problems occur in operation of press, contact ANCO (Waukesha Cherry-Burrell) Service Department for recommendations. Indiscriminate changing of pressure settings may cause excessive wear or damage to press. See general maintenance section.



NOTE: During start up and commissioning, press operating pressures are set to optimize pressed belly quality and minimize wear and heat generation. Press maximum operating pressure is 750 psig but is seldom required.

Heaters in Electrical Panels

Located in both the operator push button panel and right side mounted terminal box is a heater controlled by an adjustable thermostat. This helps to keep the enclosures internal temperature above the dew point preventing water vapors from condensing into liquid and possible damage to internal electrical components. The adjustable thermostat should be set above the dew point to prevent any condensation from occurring. The thermostats have an adjustable set point range of 30° to 140° F. There is no heater in the remote control panel because of its higher operating temperatures that prevents condensation from occurring.

Maximizer

For reduction of bacon slab wrinkles, Maximizer (Figure 1, item 7) provides a smooth, yielding contour for bacon to flow over during pressing operation. During pressing phases, pressure developed over bacon overcomes pneumatic pressure in diaphragm of Maximizer. Bottom of bacon flattens reducing amount and size of wrinkles in most bellies.

As head retracts, left end disappearing bar is pushed down, and left end disappearing bar prox (PX4) and Maximizer air solenoid valve (SOL-1) are energized. Air pressurizes space under diaphragm. When press open sequence starts (manual or auto), Maximizer solenoid valve (SOL-1) is de-energized, air is exhausted and diaphragm depressurizes.



NOTE: If wrinkles begin to appear or increase over the period of operation, check Maximizer operation. Improper air pressure or water in diaphragm will prevent Maximizer from functioning properly. Take corrective action to minimize the content of water in air. Air filter has auto float drain installed at bottom of filter bowl. Do not use air pressure exceeding 75 psi.

Maximizer Operating Instructions

1. Connect plant air supply (Figure 1, item 22) to Maximizer quick-connect fitting. Set air pressure regulator to approximately 35 psig (air must be water-free).
2. Place bellies in die box (Figure 1, item 10) with flank end left and skin side down.
3. If Maximizer diaphragm ruptures, shut off air supply and replace or repair unit. If Maximizer diaphragm cannot be immediately replaced or repaired, press operation may continue by removing Maximizer assembly and using appropriately sized and lubricated plastic block as filler unit.

Maximizer Maintenance

1. Maximizer assembly and cavity area should be cleaned daily. Remove Maximizer assembly for cleaning and for access to Maximizer cavity area. Disconnect supply air line and lift out Maximizer assembly using vacuum cups provided.
2. Maximizer diaphragm life will be increased by repositioning unit 180° after every other cleaning.
3. Replace Maximizer diaphragm by removing assembly from press, removing nuts holding assembly together and replacing ruptured diaphragm. Re-assemble when complete.



NOTE: *Recommended diaphragm replacement is every 350 hours of operation or every month, whichever occurs first, or whenever diaphragm becomes deformed.*

Maintenance

 **DANGER:** Disconnect and lock out all power sources at remote control panel when doing any maintenance on Bacon Press or before opening door of remote control panel.

 **WARNING:** Block cross arm up at both ends to maintain head level and prevent cocking when doing maintenance on any parts above table.

 **WARNING:** Relieve hydraulic pressure before servicing any parts of hydraulic system.

Press uses Mobil® DTE 25 hydraulic oil and is suitable for 25°F to 65°F room temperature. Eighty gallons of hydraulic oil is required for complete oil change in hydraulic reservoir.

 **CAUTION:** Keep fluid in hydraulic reservoir at or above black bar line on sight level glass approximately 2-1/2" from top of hydraulic reservoir.

Press is equipped with oil filter located at rear of reservoir. When filter gauge reads “needs cleaning” or approaches “bypass”, filter element should be replaced. Suction line strainer in reservoir near pump should be checked and cleaned at the same time.

When silica gel in desiccant type breather on top of hydraulic reservoir in back of press changes color from blue to pink, breather is no longer active and needs to be replaced.

Periodically check oil temperature, and siphon oil sample from reservoir to compare with clean, new oil sample.

For related information, refer to Ritter Technology Instruction and Service Manual provided.

 **NOTE:** Hydraulic oil deteriorates with use. A complete oil change is recommended at least every 3000 hours of operation or yearly, whichever occurs first, or if hydraulic oil becomes darker, thinner and has a burnt smell compared to new hydraulic oil. See hour meter on remote control panel for actual hours of run time. Consult MSDS sheet for proper oil disposal.

The following procedure should be conducted each week or every 60 operating hours:

1. Ensure all bolts on front disappearing bar assembly are tight.
2. Check die base, left end disappearing bar (See Figure 1, page 9, item 3), front disappearing bar (Figure 1, item 9) and top press plate (Figure 1, item 2) for contact.
3. Check side cylinder pusher (Figure 1, item 5), end cylinder pusher (Figure 1, item 6) and assemblies for separation between shoulder of rod and assemblies

while retracting. Separation indicates rod is backing out. **Damage will occur.**

 **NOTE:** Bolts should be removed, cleaned, primed, loctited or replaced if joints, including bolts on return linkage mounted on press plate, work loose.

 **NOTE:** Check hydraulic hoses and fittings for oil leaks and take corrective action.

 **WARNING:** Head must be supported if any hydraulic lines, hoses or fittings are opened between head cylinder, unlock valve and flow divider inside reservoir.

Flow divider and related hydraulic lines and fittings are located in reservoir under rectangular access cover. Head cocking (uneven raising or lowering) or inability to develop hydraulic pressure may be caused by leaks or flow divider problems. Remove access cover and carefully check these items. Bubbles from flow divider indicate a loose fitting or ruptured line.

 **WARNING:** Hydraulic oil leaks under pressure can penetrate skin and cause infection. Do not expose fingers or hands to hydraulic pressure leaks.

Adjustments

During initial start-up, adjustments were made to ensure proper operation of press. Carefully review electrical control schematics, hydraulic schematic and power unit assembly drawings included in print package BEFORE making adjustments. The 1411P-G3 Bacon Press uses a combination of hydraulic and electrical sequencing producing the best results when properly adjusted and maintained. Pressure adjustment, on relief valves, produce significant variation in press cycle (independent of electrical functions) and product quality. Understanding and attention must be paid to each adjustment and results of each change.

At “idle/up/open”, hydraulic power unit should be unloaded (main relief valve (SOL-4) de-energized). Pressure gauge, located at main relief valve, should indicate no more than approximately 40 psig. Low back pressure bypass condition allows fluid to stay cool. Main relief valve develops hydraulic pressure when main relief solenoid valve (SOL-4) energizes or manual override is depressed.

Main System Relief Valve

Main relief solenoid valve (SOL-4) must be energized to set maximum hydraulic system operating pressure. This can be done two ways (first method is preferred):

1. Place press in manual mode (selector switch SS1). Place and hold a steel screwdriver blade against side cylinder extended prox switch (PX9) located at end of width control bar and closest to operator. Main relief solenoid valve (SOL-4) will energize.
2. Push and hold manual override on main relief valve housing while adjusting main relief valve knob.

Read hydraulic operating pressure on pressure gauge while adjusting main relief valve knob. Typical factory relief setting is 650 psig. A lower pressure relief setting will result in lower hydraulic oil temperature.



CAUTION: Main relief valve should never be set above 750 psi to prevent warranty from becoming void and press from failing prematurely.

After all adjustments are complete, lock set screw for normal press cycles. Pressure gauge is used for startup, commissioning and periodic maintenance checks.

Sequence Valves for Side & End Cylinders

The sequence valves are located on the manifold just below the side or end directional control valves and will supply a secondary circuit for side or end cylinders with flow once pressure at the main circuit has exceeded the valve setting. This provides constant pressure in the main circuit for head and front disappearing bar cylinders while either the side or end cylinders are extending. Set sequence valves per the following:

1. Turn adjustment screw clockwise all the way in.
2. Place press in manual mode (selector switch SS1). Place and hold a steel screwdriver blade against side cylinder extended prox switch (PX9) located at end of width control bar and closest to operator. Main relief solenoid valve (SOL-4) will energize.
3. Push and hold manual override on directional control valve that controls the extending of the cylinder (Sol-6 for side cylinder and Sol-9 for end cylinder - both located on top of manifold and towards front).
4. Turn out adjustment screw counterclockwise to a point when cylinder starts extending plus as additional 1/2 turn. Lock in place.
5. Repeat procedure for other sequence valve.

Head Lock Pressure Switch

Head lock pressure switch (PS2) (See Figure 2, page 10, item 50) sets pressure needed to de-activate head unlock solenoid valve (SOL-7) (Figure 2, item 45) and locks head in place. Head lock pressure switch is located under table beside filter.

| HEAD LOCK - PS2 - SETTING TABLE | | |
|---------------------------------|--|------------------|
| Parameter | Description | Factory Settings |
| SP1 | Switch on Point (PSI) | 250 |
| rP1 | Switch off Point (PSI) | 200 |
| dS1 under EF mode | Switch on Delay 0 - 50 seconds | 0.2 |
| drl under EF mode | Switch off Delay 0 - 50 seconds | 0.2 |
| OUI | Output 1 Hysteresis Mode Normally Open | Hno |

Raise pressure on parameter SP1 to increase pressure on belly and lower pressure to decrease pressure on belly.

1. Ensure head lock selector switch Figure 3, item 68) is turned on.
2. Cycle press with a bacon to observe if head is locking at correct position. Watch for the LED on the head unlock solenoid valve (SOL-7) to turn off, this will lock the head in place.
 - a. If the LED on the head unlock solenoid valve (SOL-7) does not turn off or the bacon is over pressed, then the head lock pressure switch (PS2) limit is set too high.
 - b. If the LED on the head unlock solenoid valve (SOL-7) turns off too early, leaving the head above and not contacting the bacon or under presses the bacon, then the head lock pressure switch (PS2) limit is set too low.



CAUTION: Use a blunt point to depress pressure switch buttons to avoid damage or rupture of seal. Keep protective cover in place at all times to protect switch display when not making adjustments.

3. If adjustments are necessary, depress Mode-Enter button until SP1 is displayed.



NOTE: Pressure switch has two output set points. Model 1411P-G3 uses SP1 as a control signal. SP2 may be set to same pressure value, but will have no effect on circuit.

4. Within five seconds, depress the set button until pressure reading is displayed.
5. Within five seconds, depress set button to change displayed value until correct setting is displayed.



NOTE: Numeral display of head lock pressure switch will ascend from 20 to 1450. Hold set button to rapidly advance display.

6. Within five seconds, depress Mode-Enter button to store desired setting.
7. Cycle press with a new bacon to observe if head is locking at correct position.
8. Repeat steps 3 through 7, as necessary.

 **NOTE:** Oil temperature changes will affect hydraulic pressure settings. Regular checks may be necessary to ensure correct pressures are maintained.

Solid State Relays

Solid state relays featuring low on-state resistance are installed in the remote control panel assuring easy paralleling, switching and dependable capabilities.

 **CAUTION:** Carefully observe relay polarities and terminal numbers when installing relays. If done incorrectly, the relays will be destroyed; press may move unexpectedly and may destroy the PLC output circuit.

 **CAUTION:** Use cordsets as supplied from factory for DIN style solenoids. These cordsets have a fast recovery diode due to high Ldi/dt rates that will ensure proper operation and function of the solid state relays. Reorder cordsets through the factory; **DO NOT** use a standard diode cordset.

Cycle Timing

A complete bacon press cycle is timed from the moment start switches are activated to the instant bacon press returns to home position at idle. A normal cycle time of 4.5 seconds.

 **CAUTION:** Do not use increased hydraulic pressure to speed up bacon press operation or cycle time. Excessive hydraulic pressures contribute directly to premature wear of mating or sliding parts.

End Cylinder Relief Valve

End cylinder relief valve, located on front side of manifold, is a small cartridge-type relief valve with hollow hex cap screw adjustment. Relief valve sets maximum pressure applied to product by end cylinder. Factory setting is 450 psig but may be readjusted during startup and commissioning. Valve has a minimum of 375 psi at 45 gpm.

1. Switch press to manual mode and hold press closed.
2. Read end relief pressure on pressure switch display.
3. While in manual mode and with press closed, adjust end relief valve.
4. Lock set screw and cycle press to read new setting on display.

End Cylinder Pressure Switch and End Cylinder Pressure Delay Timer

End cylinder pressure switch (PS1) (Figure 2, item 48) sets pressure needed to activate end cylinder pressure delay timer (TDR-1) (Figure 3, item 67) in auto mode. End cylinder pressure switch is located under press table beside filter.

| END RELIEF - PS1 - SETTING TABLE | | |
|----------------------------------|--|------------------|
| Parameter | Description | Factory Settings |
| SP1 | Switch on Point (PSI) | 240 |
| rP1 | Switch off Point (PSI) | 200 |
| dS1 under EF mode | Switch on Delay 0 - 50 seconds | 0 |
| dr1 under EF mode | Switch off Delay 0 - 50 seconds | 0 |
| OU1 | Output 1 Hysteresis Mode Normally Open | Hno |

1. Switch press to auto mode.

 **NOTE:** Closing of end cylinder pressure switch only energizes end cylinder pressure delay timer in auto mode. No other press functions are changed by end cylinder pressure switch.

2. Set timer control to zero.
3. Cycle press to observe end form cylinder stroke. If end pusher does not extend fully, pressure switch limit is too low. If end pusher extends and does not retract, pressure switch limit is too high.

 **CAUTION:** Use a blunt point to depress pressure switch buttons to avoid damage or rupture of seal. Keep protective switch cover in place at all times to protect switch display when not making adjustments.

4. If adjustments are necessary, depress Mode-Enter button until SP1 is displayed.

 **NOTE:** Pressure switch has two output set points. The 1411P-G3 model uses SP1 as a control signal. SP2 may be set to same pressure value, but will have no effect on timer circuit.

5. Within five seconds, depress the Set button until pressure reading is displayed.
6. Within five seconds, depress Set button to change displayed value until correct setting is displayed.

 **NOTE:** Numeral display of pressure switch will ascend from 20 to 1450. Hold set button to rapidly advance display.

 **NOTE:** End cylinder pressure switch set point must always be set lower than end relief valve. If pressure switch is set above end relief valve, pressure will relieve, pressure switch will not close and press will not receive command to open.

7. Within five seconds, depress Mode-Enter button to store desired setting.
8. Cycle press to observe end form cylinder stroke. End cylinder pressure switch should close as soon as possible to save cycle time. End cylinder pressure switch should close as soon as end forming resistance is met.
9. Repeat steps 4 through 8, as necessary.



NOTE: Pressing a belly to test pressure switch set point ensures timer will add time to end forming and achieve proper squaring of bellies.



NOTE: Oil temperature changes will affect hydraulic pressure settings. Regular checks may be necessary to ensure correct pressures are maintained.

10. Adjust end cylinder pressure delay timer (TDR-1) from minimum to just enough pressure and time to square end of belly. Timing base is controlled by potentiometer (POT-1) labeled "End Pressing Time" located on operator station. Timer provides elapsed time for end pressing. Elapsed time starts when end cylinder pressure switch (PS1) energizes and ends when timer times out.
11. In auto mode, press then will open.

Left End Disappearing Bar Prox

Left end disappearing bar prox (PX4) is located under left end disappearing bar (front, left end of press).

1. Adjust prox switch to energize just as back of head top plate gets level with side pusher. This will allow the side pusher to come in direct contact with the head top plate preventing damage to return linkage.
2. If auto mode is selected (SS1), auto pressing engages, auto indicator (PL1) energizes and operator can remove hands from right and left hand start touch pads (PX1 & PX2 or PX3).
3. Press pinch points are considered closed and press cycle proceeds to completion.

Hydraulic Cylinder Cushions Adjustment

Hydraulic cylinders supplied on press have internal cushions designed to absorb energy and decelerate cylinder while having minimal affect on cycle time. Cushions are located at both ends of cylinder. Tightening socket head screws will increase cushion action at end of cylinder stroke. Loosening socket head screws will decrease cushion action.

Head Down/Up Cylinder Cushion Adjustment

Head Down/Up Cylinders (Figure 1, item 19) are mounted on opposite sides of Bacon Press. Socket head screws on both cylinders should be adjusted equally.

1. Turn rod-end socket head screw clockwise until tight, then counter-clockwise 1/4 turn.
2. There is no cushion located on the cap-end of this cylinder.

Side, End and Front Disappearing Bar Cylinder Cushion Adjustment

1. Turn cap-end socket head screw clockwise until tight, then counter-clockwise 1/4 turn.
2. Turn rod-end socket head screw clockwise until tight, then counter-clockwise one full turn.



CAUTION: Machine damage will occur if cylinders are allowed to hammer. If hammering occurs, report to maintenance as soon as detected and correct before next operating shift.

Replacing Cylinder Gland Packing

Jewel gland is a unique cartridge design consisting of a bronze gland, primary lipseal and double lip wiperseal, and is threaded into gland retainer plate. All sizes are removable without disturbing tie rod torque. Fluid leakage around piston rod at gland area typically indicates a need to replace gland seals.

Removing the Gland

1. Remove cylinder from machine, or, if unable to remove, disconnect piston rod from rod clevis, knuckle or machine to which it is fastened.
2. Inspect piston rod to ensure it is free of burrs or other displaced metal preventing gland from sliding off rod.
3. Unscrew gland from gland retainer plate.

! *NOTE: On low pressure hydraulic cylinders, remove bolted gland retainer by loosening four socket head screws. Gland protrudes from face of retainer and can be removed with vice grip pliers or gland wrench available for each gland size.*

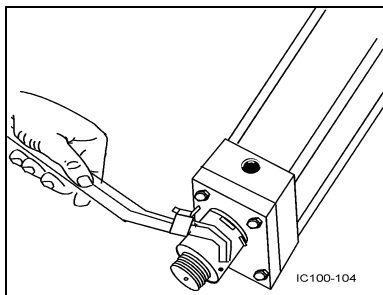

Figure 8 - Gland Wrench

4. Slide gland assembly off piston rod and remove seals.
5. Thoroughly clean gland and seal grooves.
6. Inspect gland bore for wear. If bore is worn, replace using rod gland and seal kit. (See “Hydraulic Cylinder Repair Kits” on page 27).
7. Lubricate gland seal grooves and all new seals.
8. Install wiperseal (Figure 9, item 91) in groove closest to end of gland.
9. Slightly collapse backup washer (Figure 9, item 93) and install lipseal (Figure 9, item 92) in seal groove. Ensure wiperseal is flat against wall of groove. Lips of seal should point toward long bearing side of gland.

! *NOTE: Supplied with each rod gland and seal kit, o-ring (Figure 9, item 94) serves as a seal between gland and head. O-ring is a static seal and does not normally require replacement. Original o-ring may be left in place, unless known to be leaking (fluid flow around gland thread).*

Installing The Gland

1. Inspect surface of piston rod for scratches, burrs, dents or other damage. A damaged piston rod surface will result in premature rod seal failure.
2. Lubricate bore of gland and seals, and slide gland over end of piston rod.
3. Thread gland into retainer until seated firmly against head. Gland-to-head o-ring (Figure 9, item 94) serves as a torque prevailing lock.

! *NOTE: Seals are pressure actuated and do not require further adjustments.*

! *NOTE: A slight rotary motion of gland will help prevent damage when replaced on a rod threaded to full diameter or misshaped to potentially damage seals. In addition, because full-diameter threads are usually supplied with crest of threads slightly truncated, a piece of shim stock or other thin, tough material can be wrapped around threads to help protect gland seals when passing over threads.*

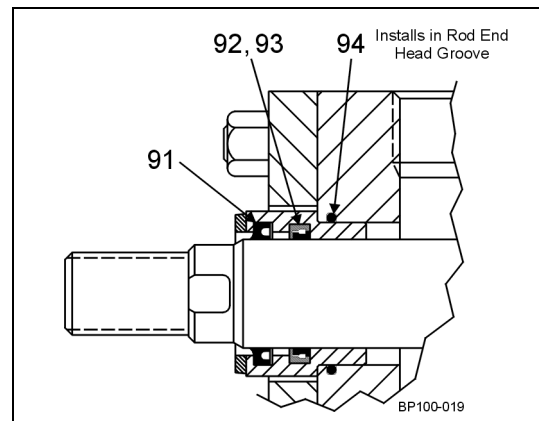

Figure 9 - Head End O-ring Seal

Hydraulic Cylinder Repair Kits

| CYLINDER PART # | HYDRAULIC CYLINDER | SIZE | ROD GLAND AND SEAL KIT | PISTON SEAL AND BODY KIT* | O-RING BODY KIT |
|------------------------|---------------------------|---|-------------------------------|----------------------------------|------------------------|
| 722654 | Front Disappearing Bar | 2" Bore x 3" Stroke 1.00 Dia. Rod | 721784 | 721785 | 721783 |
| 722179 | End Forming (right side) | 3-1/4" Bore x 16" Stroke 2.00 Dia. Rod | 722181 | 721787 | 720112 |
| 722178 | Side (rear) | 4" Bore x 10" Stroke 2.50 Dia. Rod | 722182 | 721786 | 720115 |
| 403730C04 | Head Up and Down | 4" Bore x 6" Stroke 2.50 Dia. Rod | 722182 | 720116 (Hi-Load Type) | 720115 |

*Piston Seal and Body Kit includes all parts supplied in O-ring Body Kit

Troubleshooting

During initial start-up, adjustments were made to ensure proper operation of press. Over a period of time, settings will change and press will require readjustment. Prior to taking corrective measures listed in “Troubleshooting” make these basic adjustments.

The 1411P-G3 control system PLC has LED’s for each input and output. The LED illuminates when input or output is energized. Inputs are connected to field devices detecting position or status (prox switches, selector switches, pressure switches, etc.). Outputs are connected to field devices causing an action or function (indicator lights, relays, timer). LED’s can be used when troubleshooting to indicate if a particular input or output is being energized.



NOTE: The 1411P-G3 control system uses interface relays between PLC output point and all field solenoid valves. Solid State Relays are 24VDC, panel mounted and switch separate fused power to field solenoid valves. Example: PLC output O/9 energizes relay CR11 which applies 24VDC power to SOL-1 for Maximizer Solenoid Valve.

| PROBLEM | POSSIBLE CAUSE | SUGGESTED ACTION |
|--|---|---|
| Side cylinder jerking forward and back violently with main relief valve activated and press in "idle/up/open" position. | PX7 or PX8 is staying closed when head is up. Both switches are normally closed and held open when head is fully up. In up position, both switches should be open. | Observing PLC inputs PX7 and PX8, determine if switches are defective and replace. |
| Low or insufficient system hydraulic pressure. | Main relief valve solenoid spool not shifting properly. Malfunctioning valve. | Manually override solenoid spool. If system pressure returns to normal, replace solenoid. Repair or replace, as necessary. |
| In auto, press does not open after squaring bacon end or does not open after ejecting. | End cylinder pressure switch (PS1) does not energize. End cylinder pressure delay timer (TDR-1) does not time out. Side cylinder extended prox (PX9) does not energize. | Lower end cylinder pressure switch setting. If PLC input PS1 does not energize, replace switch. Observe if PLC input (PS1) energizes, PLC output O/10 energizes timer, timing completes and PLC input I/15 energizes. If not, replace timer. Ensure base wiring is secure. If PLC input PX9 does not energize, replace prox switch. |
| Pressure from end pusher always remains equal (over-pressing large bellies, not squaring off small bellies). | Pressure switch staying closed. | Check PLC input light. If light is always on, pressure switch is staying closed. Increase pressure setting. If pressure switch still does not open, replace switch. |
| Head cocked when press is in idle. | Rods for head cylinders are threaded into cylinder pistons. Measurements between die box and bottom of press plate is 6-7/8". Rod on cocked side may have backed out of piston. | Remove piston from shaft. Clean, prime and Loctite® threads before re-securing. |

Notes

SPX[®]

PROCESS EQUIPMENT

Your local contact:



SPX Process Equipment
611 Sugar Creek Road
Delavan, WI 53115
Phone: (262)728-1900 or (800)252-5200 Fax: (262)728-4904 or (800)252-5012
E-mail: wcb@spx.com

For more information about our worldwide locations, approvals, certifications, and local representatives, please visit www.spxpe.com.

SPX Corporation reserves the right to incorporate our latest design and material changes without notice or obligation. Design features, materials of construction and dimensional data, as described in this bulletin, are provided for your information only and should not be relied upon unless confirmed in writing. Certified drawings are available upon request.