



# Scraped Surface Heat Exchangers For Industrial Duty

Votator® II

4 X 120

Votator® II Extra Heavy Duty



**SPX**®

For over seventy years, Votator® II Scraped Surface Heat Exchangers have been raising productivity, lowering production costs, and delivering more uniform end-products for a wide range of processing industries.

With Votator® units, companies in the food, chemical, petroleum, pharmaceutical, and allied industries have reduced labor costs substantially, because their reliance on expensive artisan skills have been minimized or eliminated.

Votator® II Scraped Surface Heat exchangers continue to replace many slow, inefficient batching operations with more uniform, controllable, and repeatable continuous processing. And, because of superior heat transfer performance and ability to handle a wide range of viscosities, they are still the clear choices over tubular or massive plate heat exchangers in viscous applications.

Votator® II Scraped Surface Heat Exchangers can be employed in the continuous, closed processing of virtually any pumpable fluid or slurry involving:

- Cooking
- Slush Freezing
- Cooling
- Crystallizing
- Mixing
- Plasticizing
- Gelling
- Polymerizing
- Heating
- Aseptic processing

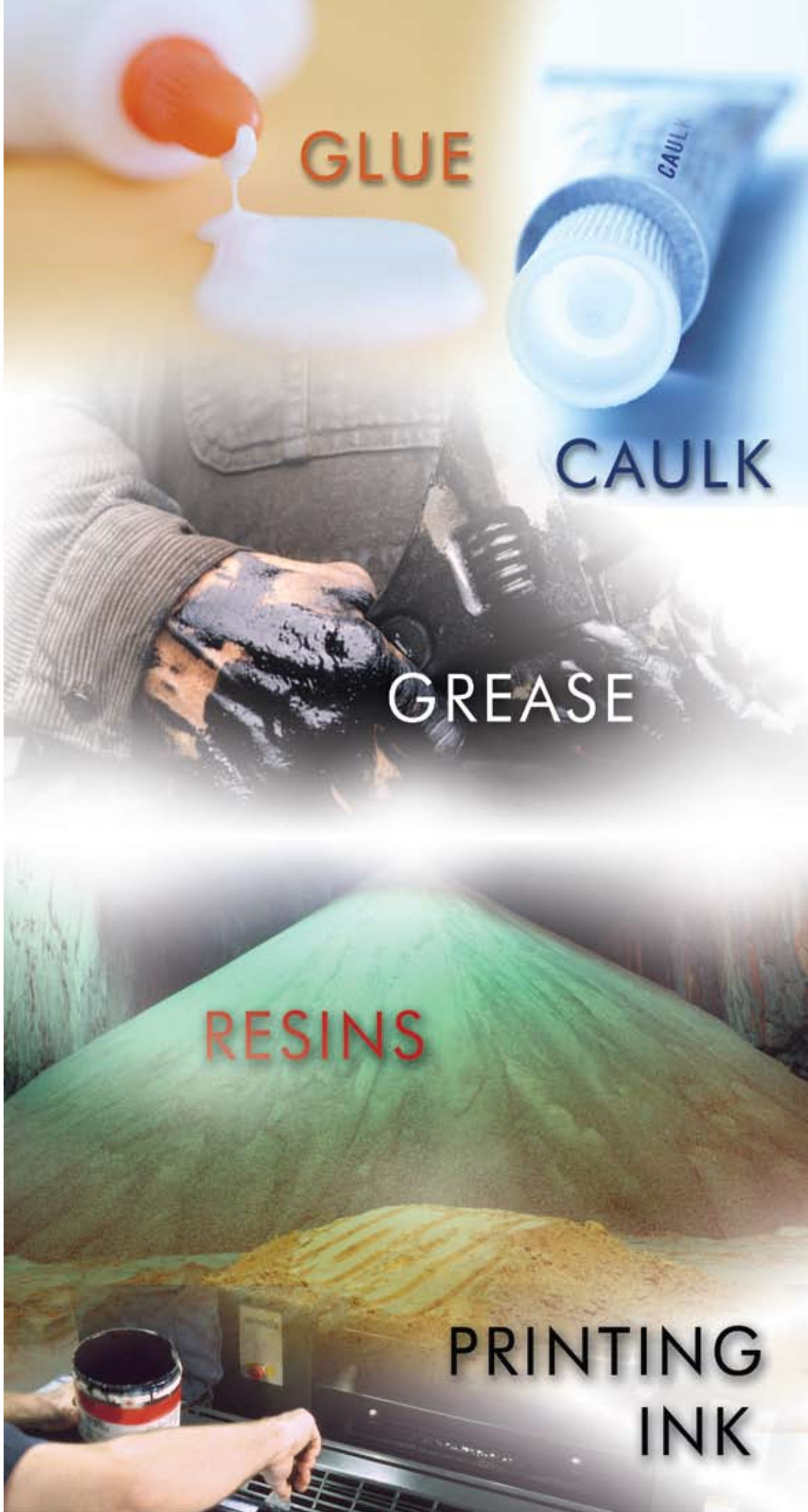

# How It Works

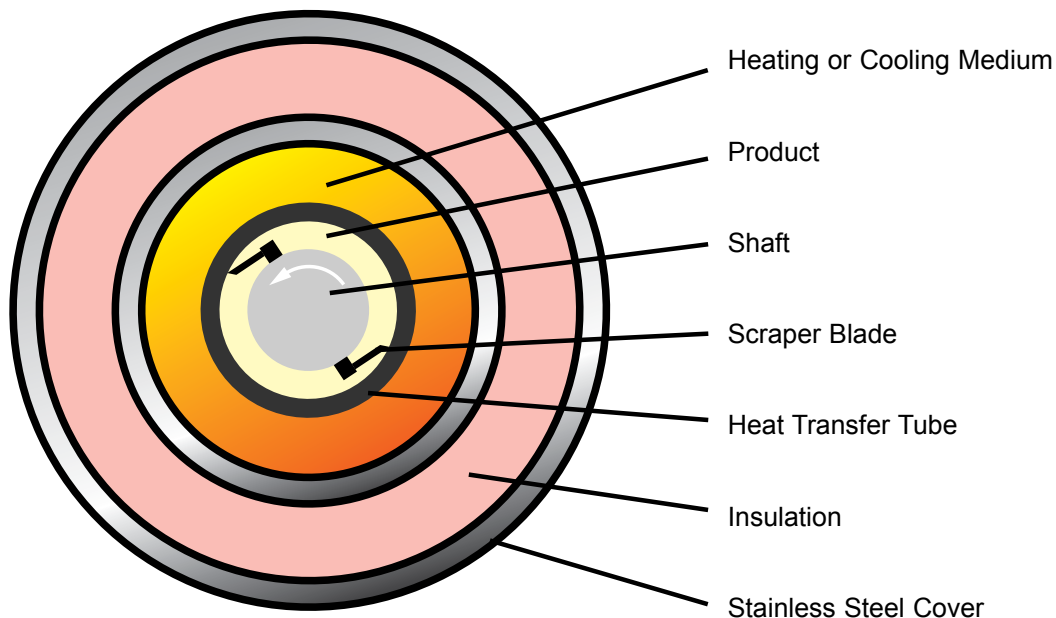

Votator's high efficiency and productivity results from a simple concept, heat or cool continuously moving product by providing a large heat transfer surface for a small amount of product in a confined space.

Inside every Votator®, a mutator shaft rotates within a tube. The product passes through an annulus formed by the shaft and heat transfer tube (light yellow). Heating or cooling medium flows in a jacket (orange). The unit is insulated (pink) to minimize energy loss and protect personnel. A stainless steel cover protects the insulation.

In operation, the rotating shaft has blades which continuously scrape product film from the heat transfer tube wall, thereby enhancing heat transfer, and agitating the product to produce a homogenous mixture.

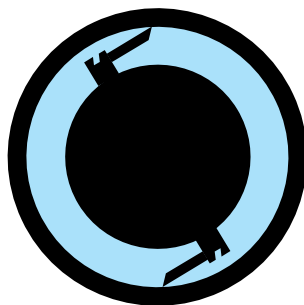

## Concentric

For most applications the shaft is mounted in the center of the heat transfer tube, or CONCENTRIC.

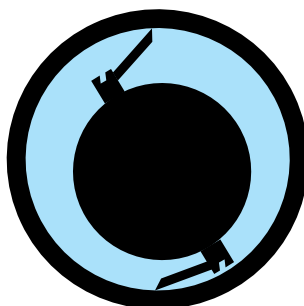

## Eccentric

An off centered shaft mount or ECCENTRIC design is recommended for viscous and sticky products. This shaft arrangement increases product mixing, eliminates mass rotation, and reduces the mechanical heat load.

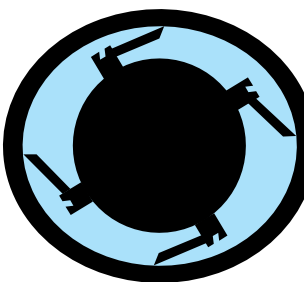

## Oval Tubes

Oval tubes are used to process extremely viscous products. This design eliminates product channeling within the tube, it reduces mechanical heat by a double cam action of the scraper blades, and it balances the internal forces to prevent shaft deflection.

# How Components Are Selected

**Votator® Scraped Surface Heat Exchanger** components are manufactured in a variety of configurations and materials so that each unit can be assembled to meet the specific processing requirement of each application.

All pressure elements are designed in accordance with the latest ASME code requirements and can be CE-PED certified.

**Jacket** – Votator® Scraped Surface Heat Exchangers can be jacketed for liquid, steam, or direct expansion refrigeration.

**Heat Transfer Tube** – Thermal conductivity and wall thickness are key design considerations in selecting heat transfer tubes. Tube wall thickness is precisely engineered to minimize heat transfer resistance while maximizing structural stability.

Pure nickel tubes provide high thermal conductivity. The inside of the tube is hard chrome plated, then honed and polished to a smooth finish for resistance to wear from scraper blades and abrasive products.

Stainless steel tubes specially designed for enhanced heat transfer are offered for acidic products and to provide flexibility in the use of cleaning chemicals.

**Scraper Blades** – Votator® scraper blades are arranged on the shaft in staggered rows. The blades are held on the Votator® Scraped Surface Heat Exchanger shaft by strong, durable, specially designed “universal pins,” which are welded to the shaft. There are no threaded areas to cause product build-up. These pins allow quick, easy blade removal and replacement. A variety of blade materials are available.

**Seals** – Years of experience led to development of the Votator® rotary mechanical seals. Seals are designed for easy assembly and maintenance, and for reliable operation.

Standard seal faces for best durability consist of hardened surfaces. Flexible seal parts are available in a variety of elastomers.

Votator® II double mechanical seals are designed with the capability to use steam or water seal flush.

**Shaft** – The amount of time the product is within the heat exchanger for a given rate is controlled by the volume of the unit.

Small-shaft heat exchangers provide a large annulus for longer residence time, they handle lumpy products and those having large particles. Large-shaft heat exchangers provide a smaller annulus for high velocity and turbulence with high heat transfer rates and short product residence time in the unit.

**Drives** – The drive for the Votator® Scraped Surface Heat Exchanger is selected to provide optimum performance in each individual application and thus assure that the product is vigorously agitated and continuously removed from the heat transfer wall. Votator® Scraped Surface Heat Exchangers are furnished with direct drive gear motors with horsepower selection for optimum performance for the specific application.

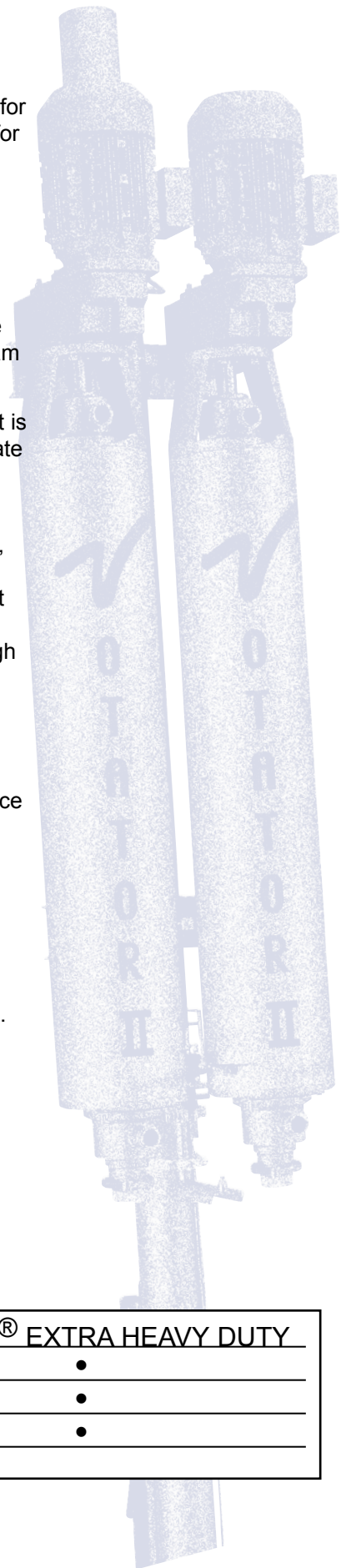

SHAFT MOUNTING	4x120	VOTATOR® II	VOTATOR® EXTRA HEAVY DUTY
CONCENTRIC	•	•	•
ECCENTRIC		•	•
OVAL			•

# Versatile In Applications



*Automotive Grease*



*Silicone Caulk*



*Wax Candles*

**Heat Sensitive Products** – Products which are degraded by prolonged exposure to heat are effectively processed in Votator® II Scraped Surface Heat Exchangers.

The scraper blades prevent product from remaining on the heat transfer surface by continuously removing and renewing the film. Because only a small amount of product is exposed to heat for just a short time, burn-on is minimized or eliminated.

**Viscous Products** – Votator® II Scraped Surface Heat Exchangers process viscous products far more efficiently than conventional plate or tubular heat exchangers.

Product film is continually scraped from the heat transfer wall to induce high heat transfer rates; constant agitation causes turbulent flow and more consistent heating or cooling; pressure drop is effectively controlled by the product annulus area; agitation eliminates stagnant areas and product build-up; and cleaning is easier.

**Particulate-Laden Products** – Products with particulates which tend to plug conventional heat exchangers are handled easily in Votator® II Scraped Surface Heat Exchangers, and the particulates maintain maximum product identity.

**Crystallized Product** – Products which crystallize are ideal candidates for Votator® II Scraped Surface Heat Exchanger processing. As product crystallizes on the heat transfer wall, the scraper blades remove it and keep the surface clean.

**Chemical Processing** – the chemical, pharmaceutical, and petrochemical industries can employ Votator® II Scraped Surface Heat Exchangers in many processes, which can be grouped in four general categories.

## **1. Heating and Cooling** -

Processing very viscous materials is not a problem for the Votator II Scrape Surface Heat Exchanger. The product film is scraped from the hot or cold tube surface many times a minute, preventing a fouled or frozen layer from forming to block further heat transfer. The total product flow area is generous, so pressure drop is minimized.

**2. Crystallization** - The Votator II Heat Exchanger can be used as a sidearm cooler, cooling a batch tank to the saturation temperature where solutes begin to crystallize. Recirculating through the heat exchanger at a high flow rate produces seed crystals that grow large enough to separate after the final temperature is reached. Waxes and other products that completely solidify can be cooled almost to the melting point in a one-pass operation, then filled into molds, deposited on cold belts, or pelletized using additional equipment.

**3. Reaction Control** - Chemical reactions can be driven by the controlled addition of heat using a Votator II Heat Exchanger. For exothermic reactions, the heat exchanger removes the heat of reaction to prevent degradation of the product or unwanted side reactions. The heat exchanger can be operated at pressures up to 600 psig.

**4. Any of the Above with Aeration or Mixing** - The Votator II Heat Exchanger delivers intense mixing to the product as it flows along the rotating shaft, so that a gas can be incorporated into a product at the same time that it is heated or cooled. A foamed material can be manufactured by addition of gas, rather than by relying on a chemical reaction to generate the gas bubbles as a by-product. The mixing action also promotes uniform distribution of crystals in a matrix or improves reaction kinetics by intimately mixing the reactants.

# Votator® 4 x 120 Scraped Surface Heat Exchanger

The 4 x 120 is a unique concentric heat exchanger designed for heating and cooling moderately viscous products. The heat transfer cylinder is 4 inches (102 mm) in diameter by 120 inches (3048 mm) long.

## FEATURES

- All **316 stainless steel** construction with high efficiency 0.083 **stainless steel heat transfer tube or optional AL6XN tube**
- Available with **9 ft<sup>2</sup> (0.84 m<sup>2</sup>) heat transfer area**
- **Horizontal units can be mounted side by side** with up to 8 cylinders per frame or furnished loose for vertical mount
- All units suitable for **steam or liquid media**
- **Mechanical seal with flush connection** on drive end with sleeve bearing on non-driven end
- **3 and 5 horsepower (2.2 kW – 5.5 kW) gear drives with shaft speeds of 90 and 175 rpm; No couplings, belts or sheaves**
- **Product side pressure of 200 psig (14 bar) @ 365° F (185° C)**  
**Jacket pressure of 150 psig (10.5 bar) @ 365° F (185° C)**
- **2.375 inch (60 mm) shaft diameter for particulates up to 0.75 inches (19 mm)**
- 2 inch S-line product connections 1-1/2 FPT media connections
- Easy to field insulate after installation
- 3A and CE-SEP compliant

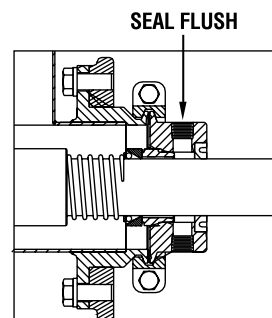

*Drive end  
mechanical seal  
(Ceramic or Graphitar)*

## DIMENSIONAL DATA MODEL 4 x 120

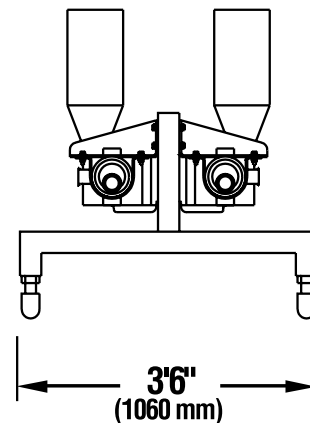
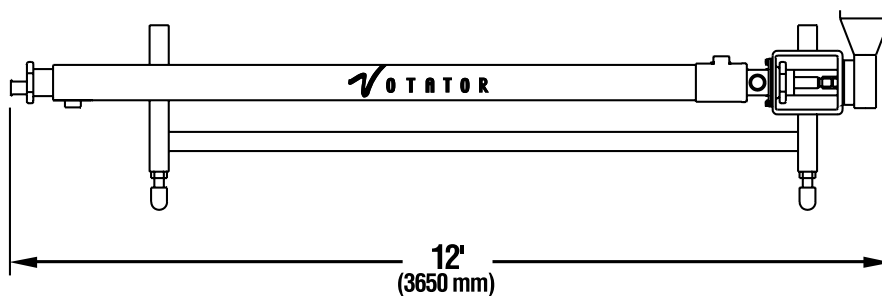

# Votator® II Scraped Surface Heat Exchanger

The Votator® II is the newest design of scraped surface heat exchangers. It is a combination of design features from the proven Votator family, Thermutator Heat Exchangers, and new innovations resulting in a rugged, economical, and reliable heat exchanger that can be used for heating and cooling products of a wide range of viscosities, including extremely thick and sticky products that require the cam action of the eccentric design.

## FEATURES

- Can be mounted **vertically or horizontally**
- Sanitary appearance
- Minimum overall length
- **USDA, CFIA, 3A, and ASME** design standard;  
CE-PED optional
- Tough 2 inch (50 mm) shaft spline
- Steam / water or gravity / pumped liquid refrigerant jacket configurations
- Concentric or eccentric shaft mounting

## PROCESS MATCHED

- Drives From **7-1/2 TO 20 HP**
- Wide range of output speeds
- Chrome plated nickel or carbon steel heat transfer tubes or 316 stainless steel tubes specially designed for **enhanced heat transfer**
- Stainless **steel** or **plastic scraper blades**
- Mutator shaft diameter based on fluid properties,  
2-1/2, 4, 4-1/2, and 5-1/4 inches (63, 102, 114, and 133 mm)
- Single and double mechanical seals

## EASY TO MAINTAIN

- **Stainless steel** exterior and stainless steel painted drive
- Open stainless steel mounting frame
- **Boltless V-Lock heads** for quick disassembly
- Splined mutator shaft **removes in minutes**
- Unique **boltless** blade mounting pins
- Gear motor drive - **no couplings, belts or sheaves**
- Heat transfer tube **separate** from media jacket. It has a reliable double O-ring seal on each end and can be removed from the jacket in minutes without disturbing the media piping.

## DIMENSIONAL DATA MODEL 6 X 72

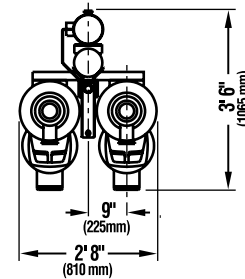
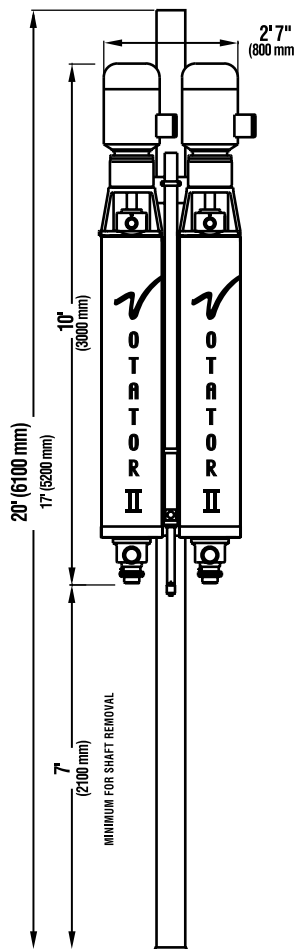
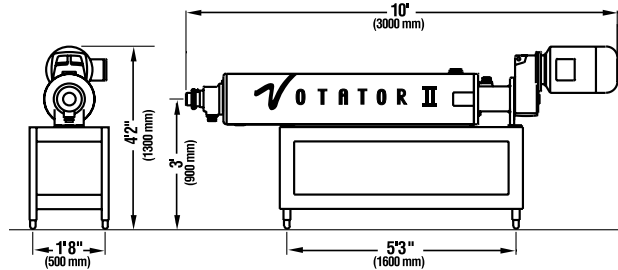

MODELS AVAILABLE	HEAT TRANSFER AREA
6 x 24	3.0 ft <sup>2</sup> (0.28 m <sup>2</sup> )
6 x 36	4.2 ft <sup>2</sup> (0.39 m <sup>2</sup> )
6 x 48	6.0 ft <sup>2</sup> (0.56 m <sup>2</sup> )
6 x 72	9.0 ft <sup>2</sup> (0.84 m <sup>2</sup> )
6 x 84	11.0 ft <sup>2</sup> (1.0 m <sup>2</sup> )

### PRODUCT SIDE PRESSURE

600 psi (42 bar) @ 400° F (204° C)  
or  
800 psi (56 bar) @ 400° F (204° C)

### JACKET PRESSURE

250 psi (17.5 bar) @ 400° F (204° C)  
or  
150 psi (10.3 bar) @ 400° F (204° C)

# Votator® II Extra Heavy Duty Scraped Surface Heat Exchanger

The Votator® name carries with it the reputation of durability that is unequalled. The Extra Heavy Duty Votator® II is capable of heating and cooling products with viscosities in the 1,000,000 centipoise range. The units have high torque 17-4 PH stainless steel drive spline, can be equipped with direct drives with up to 30 horsepower, and are available with Concentric, Eccentric or Oval heat transfer tubes to provide optimum processing conditions for any product.

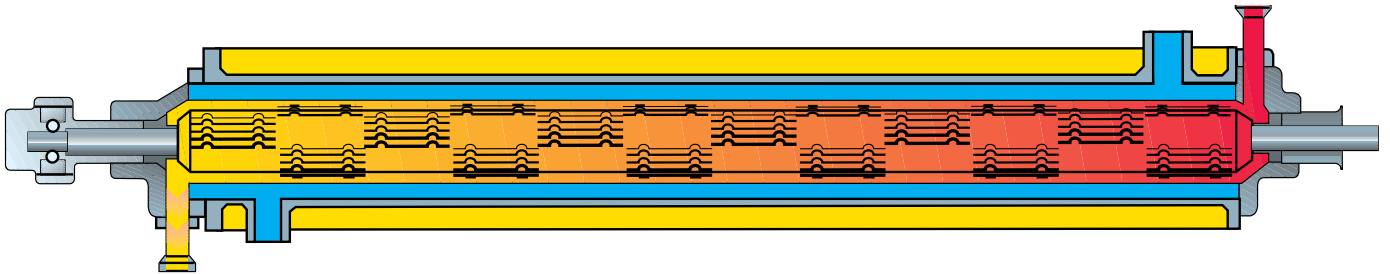

## FEATURES and OPTIONS

The Extra Heavy Duty (XHD) Scraped Surface Heat Exchanger is now available as a Votator II option. The Extra Heavy Duty option has a special heavy-duty roller bearing on the non-driven product head and a high torque 17-4 PH Stainless Steel spline on the driven end of the Mutator shaft. The motor pedestal is modified to use a larger gear drive with a 20, 25, or 30 Horsepower motor. Other mechanical features and most options are the same as the standard Votator® II.

- The **overall dimensions of the unit and space requirements** are the same as the Votator II.
- It has **bayonet locking product heads without bolts**.
- The integral Nord gear motor drive with a stainless steel mounting pedestal - without the traditional drive shaft and motor coupling - **reduces the overall length or height of the unit by over 2 feet**.
- It has a flange bolted heat transfer tube with a double O-ring seal on each end of the jacket, drastically **reducing the maintenance time** associated with servicing that component.
- The mechanical seal is **same design as the standard Votator® II and is available as a single or double seal**.
- **A spider head with bushing** is optional for the non-driven product head. This option provides a 6-inch (150mm) flanged di charge port which can accept an extrusion nozzle.

# Votator® II Easy to Maintain



**1** After any servicing or inspection, the **Votator® II** reassembles quickly and easily: simply insert the self-aligning spline end of the mutator shaft into the hollow shaft in the gear motor drive. There is no complex shaft coupling, no sensitive stub shaft alignment, or vulnerable drive belts to service.



**2** Boltless V-Lock heads let you remove the shaft for inspection or routine maintenance in minutes..



**3** Scraper blades are secured to the mutator shaft by the **Votator® II** universal mounting pins, and are easily and quickly removed and replaced.



**4** One-piece rotating seal body provides durability and simplifies maintenance.

**5** And the seal spring is out of the product zone.

**6** The heat transfer tube is bolted to the jacket assembly. The seal design for both ends features double O-rings. The tube can be removed easily without disturbing or disconnecting the media piping.

**7** Hydraulic lift mechanism guides the mutator shaft through its full range of travel.

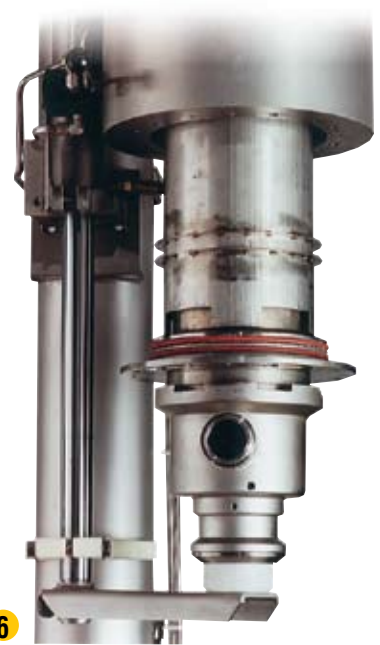

**6**



**7**

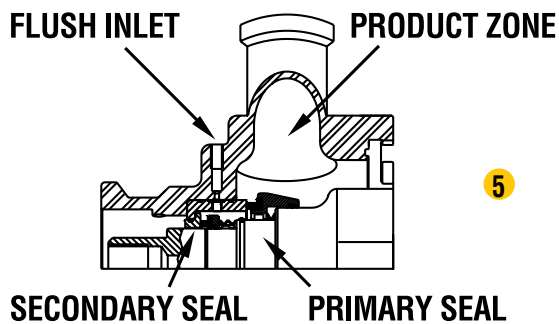

**5**

**4**

# Versatile Heat Transfer Systems

## Liquid / Steam Jacketing

When using a liquid heat transfer medium, it is necessary to maintain a high flow rate for optimum efficiency. This is accomplished by using a centrifugal pump to maintain a constant media flow. A controller monitors the product temperature out of the Votator® II heat exchanger and allows liquid media from the supply to be introduced into the loop as required.

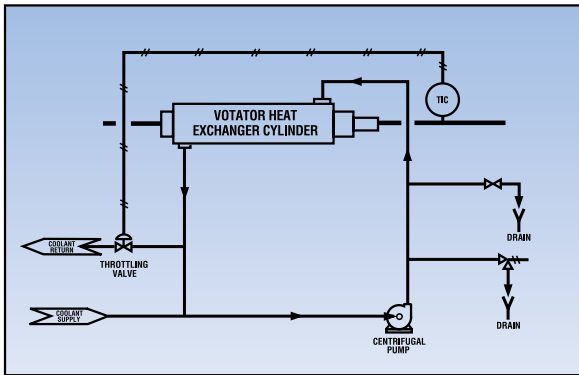

Brine Water Steam

## Gravity System

In the gravity refrigeration system, liquid refrigerant flows from a receiver in the compressor plant to a surge drum installed above the Votator® II or the Votator® II Extra Heavy Duty. A modulating thermostatically controlled expansion valve automatically maintains the correct refrigerant level in this vessel. Gravity forces the refrigerant into the cooling jacket, where product heat vaporizes a portion of the liquid and reduces the bulk density of the remainder. The flow of vapor and this density difference combine to create the classic “thermosyphon effect,” which forces liquid refrigerant to circulate from the surge drum to the cooler. A regulating valve controls the pressure in the surge drum and, consequently, the temperature of the refrigerant in the cooling cylinder. Make-up liquid enters through the level control and the entire cycle continues. Individual surge drums can be provided for each cooling cylinder or a single drum can be used for two cylinders.

The gravity system protects against freeze-up through an instantaneous current relay system. Optional hot gas controls also can be provided for freeze-up protection and to assist in removing refrigerant for pump down.

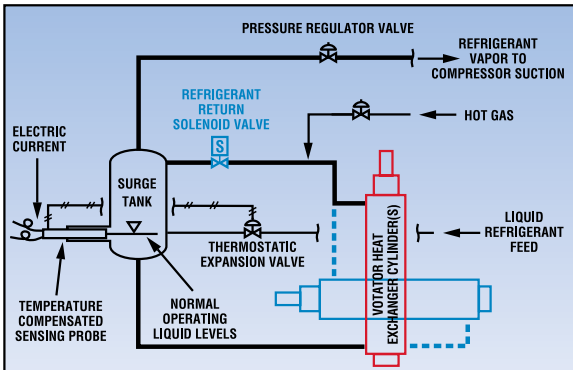

Gravity System

## Liquid Overfeed Refrigeration System

Liquid Overfeed (LOF) is available on the Votator® II and the Votator® II Extra Heavy Duty. It is a proven direct expansion concept in which only 25-35% of the liquid refrigerant flowing to the heat exchanger is actually vaporized. A large low pressure receiver replaces individual surge drums. This receiver, normally located in the compressor plant, is designed to separate the vapor from the circulated liquid. Waukesha Cherry-Burrell has designed many scraped surface heat exchangers for operating with Liquid Overfeed refrigeration. Overload protection against freeze-up is included and hot gas systems can be provided.

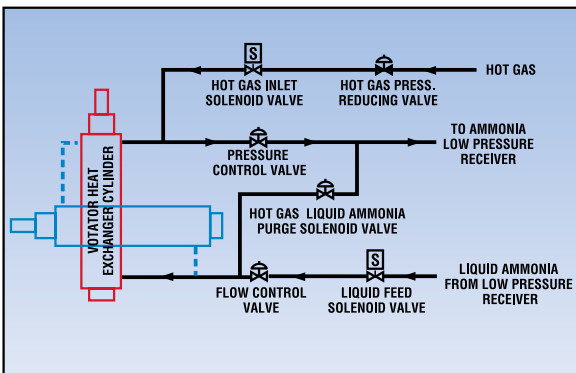

Liquid Overfeed Refrigeration System

# Industrial Votator Applications

## Printing Ink Compound

Votator® Scraped Surface Heat Exchangers are cooling and crystallizing these products at many plants. Most commonly, polyethylene wax beads are dissolved in a hot carrier like linseed oil, varnish, or other solvent and then rapidly cooled. The wax crystallizes in numerous very fine particles, trapping the liquid carrier in a soft paste. These products are blended with inks for high-speed printing presses, serving as an anti-smear agent where particle size is critical for best print quality.



## Pelletizing

Many chemical and polymer products solidify on cooling from high reaction temperatures. The shape and size of the particles depend on the final cooling system employed – a flaking roll, a belt cooler, or an underwater pelletizer are a few possibilities. A Votator® II unit can easily pre-cool even very viscous resins to near the melting point, so that the final cooling system can operate at maximum capacity.

## Chemical Reactions

Votator® Scraped Surface Heat Exchangers are ideal for carrying out fast chemical reactions in a one-pass, continuous system when reactants are viscous or immiscible. Examples include sulfonation and nitration of organic compounds. Vigorous agitation produces a fine dispersion of the reactants for maximum reaction rate, increased yield, and fewer side reactions. For reactions that proceed more slowly, like some polymerizations, the Votator® unit can be employed as a side-arm heat exchanger while reactants are recirculated around a batch reactor vessel.



## Grease

Votator® engineers pioneered an early process for continuous production of high quality lithium and aluminum complex lubricating greases. Modern batch and continuous grease processes have improved since then, but the Votator® II remains the best way to cool the grease before packaging. It can crystallize the solid-phase ingredients without fouling on the heat transfer surface, and the uniform treatment ensures a product with consistent physical properties.

# Votator<sup>®</sup> Scraped Surface Heat Exchangers



*Liquid or Steam Votator<sup>®</sup> II*



*Votator<sup>®</sup> 4 x 120*



*Vertical Votator<sup>®</sup> II*



*Gravity Accumulator Votator<sup>®</sup> II*



*Liquid Overfeed Refrigeration Votator<sup>®</sup> II*

# SPX<sup>®</sup>

## PROCESS EQUIPMENT

Your local contact:



SPX Process Equipment  
611 Sugar Creek Road  
Delavan, WI 53115  
Phone: (262)728-1900 or (800)252-5200 Fax: (262)728-4904 or (800)252-5012  
E-mail: [wcb@spx.com](mailto:wcb@spx.com)



For more information about our worldwide locations, approvals, certifications, and local representatives, please visit [www.spxpe.com](http://www.spxpe.com).

SPX reserves the right to incorporate our latest design and material changes without notice or obligation. Design features, materials of construction and dimensional data, as described in this bulletin, are provided for your information only and should not be relied upon unless confirmed in writing. Certified drawings are available upon request.