



Instruction Manual

200 Series

Centrifugal Pumps



Read and understand this manual prior to operating or servicing this product.





611 Sugar Creek Road
Delavan, WI 53115

Tel: (800) 252-5200 or (262) 728-1900

Fax: (800) 252-5012 or (262) 728-4904

E-mail: wcb@spx.com

Web site: www.gowcb.com

Information contained in this manual is subject to change without notice and does not represent a commitment on the part of SPX Corporation. No part of this manual may be reproduced or transmitted in any form or by any means, electronic or mechanical, including photocopying and recording, for any purpose, without the express written permission of SPX Corporation.

Copyright © 2001, 2010 SPX Corporation.
All Rights Reserved.

Gore-Tex is a registered trademark of W.L. Gore & Associates, Inc.

Kalrez is a registered trademark of DuPont Dow Elastomers.

Chemraz is a registered trademark of Greene, Tweed & Co.

Revision Date: 10/2010

Publication: 95-03009

Warranty	5
Shipping Damage or Loss	5
Warranty Claim	5
Safety	6
Care of Stainless Steel	7
Stainless Steel Corrosion	7
Elastomer Seal Replacement Following Passivation	7
Introduction	8
Manual Content	8
Receiving Your Pump	8
Receiving and Inspection	8
Pump Characteristics	9
200 Series Base Mount Description	9
Base Mount Components	9
Motor Adapter	9
Stand	10
Base (Optional)	10
Performance Characteristics	13
Authorization	13
Standard Construction	13
Construction Options	13
Operating Parameters	14
Capacities	15
Dimensions	16
Centrifugal 200 Series Pump and Pedestal Weights	22
Installation	24
Pump Location	24
Pump Leveling	24
Supply and Discharge Piping/Valves	24
Installations That May Cause Operation Problems	26
Electrical Connections	26
Flush Seal Option	27
Type 4 Seal (Double mechanical with flush)	27
Before First Startup	28
Clean Pump and Piping	28
Cleaning Safety Procedures	28
Manual Cleaning	28
Cleaning-In-Place (CIP)	28
Preliminary Test Run	29
Check For Possible Motor Overload Conditions	29
Operation	30
Starting the Pump	30
Priming the Pump/Stopping the Pump	30
Priming the Pump With the Feed Source Above Pump Level	30
Priming the Pump With the Feed Source Below Pump Level	31
Stopping the Pump	31
Maintenance	32
Scheduled Maintenance	32
Routine Maintenance	32
Disassembly of Pump With a Type 1 Seal	32
Removal of the Water Cascade	32
Inspect Parts	34
Assembly of Pump With a Type 1 Seal	34
Backplate Assembly	34
Backplate/Impeller Assembly	35

Type 4 Double Seal	37
Disassembly of Type 4 Seal	37
Removal of the Water Cascade	38
Assembly of Type 4 Seal	39
Disassembly of Modular Base-Mounted Pumps	41
Disassembling the Outer Seal Assemblies	42
Assembling the Outer Seal Assemblies	42
Pre-assembled (Cartridge) Seals	43
Disassembly of Pre-assembled (Cartridge) Seals	43
Assembly of a Pump With Pre-assembled (Cartridge) Seals	44
Pedestal Base-Mounted Pump Housing Lubrication	46
Pump Alignment	46
Checking Angular Alignment	46
Checking Parallel Alignment	46
Servicing the Electric Motor	47
General Service Information	47
Motor Lubrication Instructions	47
Standard Seal Dimensions	48
Cartridge Seal Dimensions	49
Parts Lists	50
Type 1 Seal Kits	50
Type 4 Seal Kits	51
Type 1 Seal Components and Common Parts	52
Type 4 Seal Components and Common Parts	54
2045 Pump Parts	56
2065LV - 2065 - 2065HV Pump Parts	58
2075 Pump Parts	60
2085LV - 2085 Pump Parts	62
2105 Pump Parts	64
Style "C" Small Bore Pedestal Mount Parts	66
Style "C" Large Bore Pedestal Mount Parts	68
Motor Mounts	70
Motor Shaft Shims	70
Troubleshooting	71

Warranty

Seller warrants its products to be free from defect in materials and workmanship for a period of one (1) year from the date of shipment. This warranty shall not apply to products which require repair or replacement due to normal wear and tear or to products which are subjected to accident, misuse or improper maintenance. This warranty extends only to the original Buyer. Products manufactured by others but furnished by Seller are exempted from this warranty and are limited to the original manufacturer's warranty.

Seller's sole obligation under this warranty shall be to repair or replace any products that Seller determines, in its discretion, to be defective. Seller reserves the right either to inspect the products in the field or to request their prepaid return to Seller. Seller shall not be responsible for any transportation charges, duty, taxes, freight, labor or other costs. The cost of removing and/or installing products which have been repaired or replaced shall be at Buyer's expense.

Seller expressly disclaims all other warranties, express or implied, including without limitation any warranty of merchantability of fitness for a particular purpose. The foregoing sets forth Seller's entire and exclusive liability, and Buyer's exclusive and sole remedy, for any claim of damages in connection with the sale of products. In no event shall Seller be liable for any special consequential incidental or indirect damages (including without limitation attorney's fees and expenses), nor shall Seller be liable for any loss of profit or material arising out of or relating to the sale or operation of the products based on contract, tort (including negligence), strict liability or otherwise.

Shipping Damage or Loss

If equipment is damaged or lost in transit, file a claim at once with the delivering carrier. The carrier has signed the Bill of Lading acknowledging that the shipment has been received from the seller in good condition. Seller is not responsible for the collection of claims or replacement of materials due to transit shortages or damages.

Warranty Claim

Warranty claims must have a **Returned Goods Authorization (RGA)** from the Seller before returns will be accepted.

Claims for shortages or other errors, exclusive of transit shortages or damages, must be made in writing to Seller within ten (10) days after delivery. Failure to give such notice shall constitute acceptance and waiver of all such claims by Buyer.

Safety

READ AND UNDERSTAND THIS MANUAL PRIOR TO INSTALLING, OPERATING OR SERVICING THIS EQUIPMENT

Waukesha Cherry-Burrell recommends users of our equipment and designs follow the latest Industrial Safety Standards. At a minimum, these should include the industrial safety requirements established by:

1. Occupational Safety and Health Administration (OSHA), Title 29 of the CFR
Section 1910.212- General Requirements for all Machines
2. National Fire Protection Association, ANSI/NFPA 79
ANSI/NFPA 79- Electrical Standards for Industrial Machinery
3. National Electrical Code, ANSI/NFPA 70
ANSI/NFPA 70- National Electrical Code
ANSI/NFPA 70E- Electrical Safety Requirement for Employee Workplaces
4. American National Standards Institute, Section B11

Attention: Servicing energized industrial equipment can be hazardous. Severe injury or death can result from electrical shock, burn, or unintended actuation of controlled equipment. Recommended practice is to disconnect and lockout industrial equipment from power sources, and release stored energy, if present. Refer to the National Fire Protection Association Standard No. NFPA70E, Part II and (as applicable) OSHA rules for Control of Hazardous Energy Sources (Lockout-Tagout) and OSHA Electrical Safety Related Work Practices, including procedural requirements for:

- Lockout-tagout
- Personnel qualifications and training requirements
- When it is not feasible to de-energize and lockout-tagout electrical circuits and equipment before working on or near exposed circuit parts

Locking and Interlocking Devices: These devices should be checked for proper working condition and capability of performing their intended functions. Make replacements only with the original manufacturer's renewal parts or kits. Adjust or repair in accordance with the manufacturer's instructions.

Periodic Inspection: Industrial equipment should be inspected periodically. Inspection intervals should be based on environmental and operating conditions and adjusted as indicated by experience. At a minimum, an initial inspection within 3 to 4 months after installation is recommended. Inspection of the electrical control systems should meet the recommendations as specified in the National Electrical Manufacturers Association (NEMA) Standard No. ICS 1.3, Preventative Maintenance of Industrial Control and Systems Equipment, for the general guidelines for setting-up a periodic maintenance program.

Replacement Equipment: Use only replacement parts and devices recommended by the manufacturer to maintain the integrity of the equipment. Make sure the parts are properly matched to the equipment series, model, serial number, and revision level of the equipment.

Warnings and cautions are provided in this manual to help avoid serious injury and/or possible damage to equipment:



DANGER: marked with a stop sign.

Immediate hazards which WILL result in severe personal injury or death.



WARNING: marked with a warning triangle.

Hazards or unsafe practices which COULD result in severe personal injury or death.



CAUTION: marked with a warning triangle.

Hazards or unsafe practices which COULD result in minor personal injury or product or property damage.

Care of Stainless Steel

Stainless Steel Corrosion

Corrosion resistance is greatest when a layer of oxide film is formed on the surface of stainless steel. If film is disturbed or destroyed, stainless steel becomes much less resistant to corrosion and may rust, pit or crack.

Corrosion pitting, rusting and stress cracks may occur due to chemical attack. Use only cleaning chemicals specified by a reputable chemical manufacturer for use with 300 series stainless steel. Do not use excessive concentrations, temperatures or exposure times. Avoid contact with highly corrosive acids such as hydrofluoric, hydrochloric or sulfuric. Also avoid prolonged contact with chloride-containing chemicals, especially in presence of acid. If chlorine-based sanitizers are used, such as sodium hypochlorite (bleach), do not exceed concentrations of 150 ppm available chlorine, do not exceed contact time of 20 minutes, and do not exceed temperatures of 104°F (40°C).

Corrosion discoloration, deposits or pitting may occur under product deposits or under gaskets. Keep surfaces clean, including those under gaskets or in grooves or tight corners. Clean immediately after use. Do not allow equipment to set idle, exposed to air with accumulated foreign material on the surface.

Corrosion pitting may occur when stray electrical currents come in contact with moist stainless steel. Ensure all electrical devices connected to the equipment are correctly grounded.

Elastomer Seal Replacement Following Passivation

Passivation chemicals can damage product contact areas of WCB equipment. Elastomers (rubber components) are most likely to be affected. Always inspect all elastomer seals after passivation is completed. Replace any seals showing signs of chemical attack. Indications may include swelling, cracks, loss of elasticity or any other noticeable changes when compared with new components.

Introduction

Manual Content

Maintenance procedures in this manual do not cover aseptic or high pressure pump applications. These are covered in special addendums available from your Waukesha Cherry-Burrell representative.

Receiving Your Pump

All ports are covered at the factory to keep out foreign objects during transit. If the covers are missing or damaged, thoroughly inspect the fluid head, by removing the pump cover (if applicable). Be sure that the pumping head is clean and free of foreign material before rotating the shaft. Each Waukesha pump is shipped completely assembled, lubricated, and ready for use. Make sure you review "Operation" on page 30 before operating your pump.

Receiving and Inspection

1. WCB equipment is inspected prior to shipment. When leaving the factory, it is well-crated for normal transportation procedures. WCB cannot, however, guarantee safe arrival. Therefore, upon receipt of this equipment, check the received items against the packing list for damaged or missing parts. Check the packing material thoroughly for small parts.
2. Visually inspect for damage or loss. Immediately report any damage or loss to the delivery carrier while present. Following the immediate notification of the lost or damaged parts, make a claim against the carrier including a detailed description of the loss or damage, and a cash value. WCB's responsibility terminates F.O.B. point of manufacture unless otherwise specified per the General Terms and Conditions of Sale as published by WCB and amended from time to time. Contact WCB Order Services if shipping information is required for handling claims.

See also "Shipping Damage or Loss" on page 5.

Pump Characteristics

The Waukesha 200 Series Pump is built for extremely durable service. The casing, backplate and impeller/stub shaft are cast 316L stainless steel for extra strength and resistance to line shock and corrosion. Large bearings and shaft provide positive alignment and minimize vibration.

The casing is clamped to the motor adapter bracket (close coupled) or bearing housing (base mount) for easy disassembly while permitting 360 degree rotation of the discharge port.

200 Series pumps are available with three standard seal types:

- Type 1: Single mechanical seal, externally-mounted and balanced.
- Type 1C: Single mechanical seal with water cascade flush.
- Type 4: Double mechanical seal with flush housing.

All seal components are interchangeable between models. All seal assemblies use an externally-mounted, balanced rotary seal for longer seal life and better sealing capability. The stationary seal face is reversible and replaceable.

200 Series pumps are designed for a broad range of sanitary and industrial applications. Sanitary models are designed for clean-in-place and meet U.S.D.A. and 3A Standards.

200 Series Base Mount Description

The Waukesha 200 Series Modular Base Mounted Centrifugal Pump design consists of four components (in addition to pump and motor). These components are used in various combinations and arrangements to provide flexibility to meet various needs.

Base Mount Components

Bearing Housing (Pump Adapter)

- The bearing housing is made of epoxy-coated cast iron with 316 SS shaft, ball bearings.
- The adapter mounts to the pump components (the same components are used for close coupled pumps).
- The bearing housing also includes a coupling for the motor shaft plus guards used in style "C" arrangements.

Style "C" Arrangement

The style "C" arrangement is composed of the bearing housing and base with the stand attached to the bearing housing, for use with foot-mounted T-frame motors. The pump and motor are mounted and supported independently. (Figure 1).

Motor Adapter

- The motor adapter is made of epoxy-coated cast iron.
- The motor adapter is used to mount a standard NEMA C-face motor onto the bearing housing.
- The motor adapter is used to provide an accurate, rigid shaft alignment.

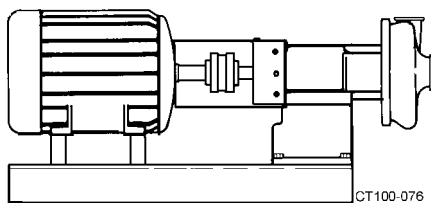

Figure 1 - Style C

Stand

- The stand (pedestal) is made of epoxy-coated cast iron.
- The stand attaches under the motor adapter or bearing housing.

Base (Optional)

- The epoxy-coated channel base is used in style "C" arrangements. See "Table of Base Size Used On Modular Base Mounted Centrifugal Pumps" on page 20.

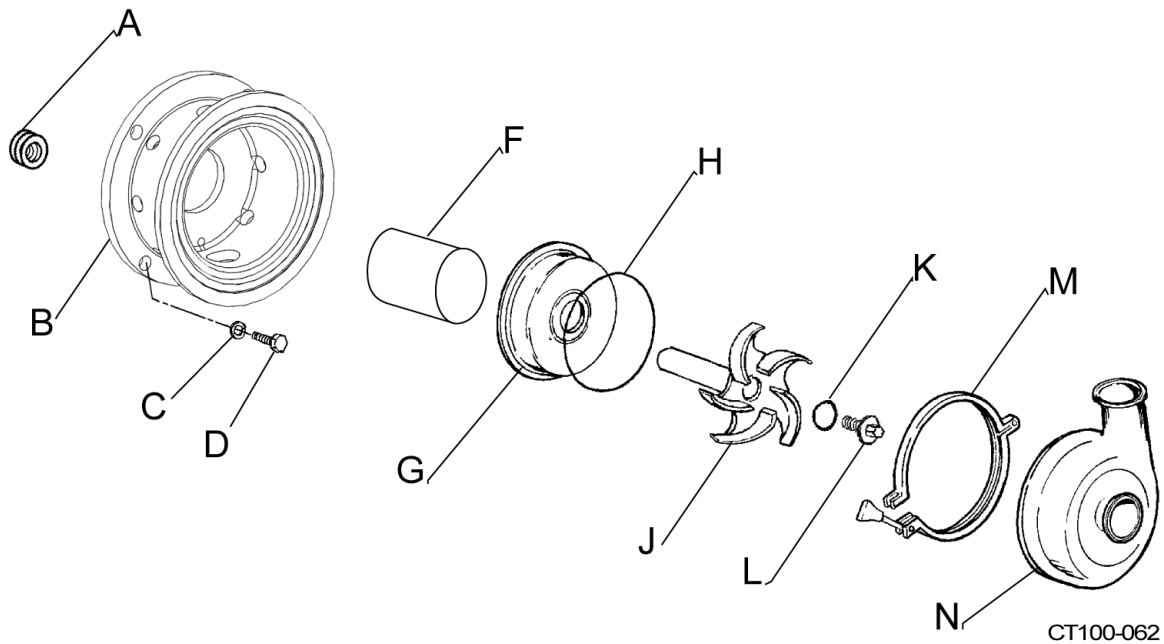
**Figure 2 - Common Part Identification**

A. Motor Shims	H. O-ring
B. Motor Adapter	J. Impeller
C. Lock Washer	K. O-ring
D. Cap Screws	L. Impeller Retainer
F. Seals (detail not shown)	M. Clamp
G. Backplate	N. Casing

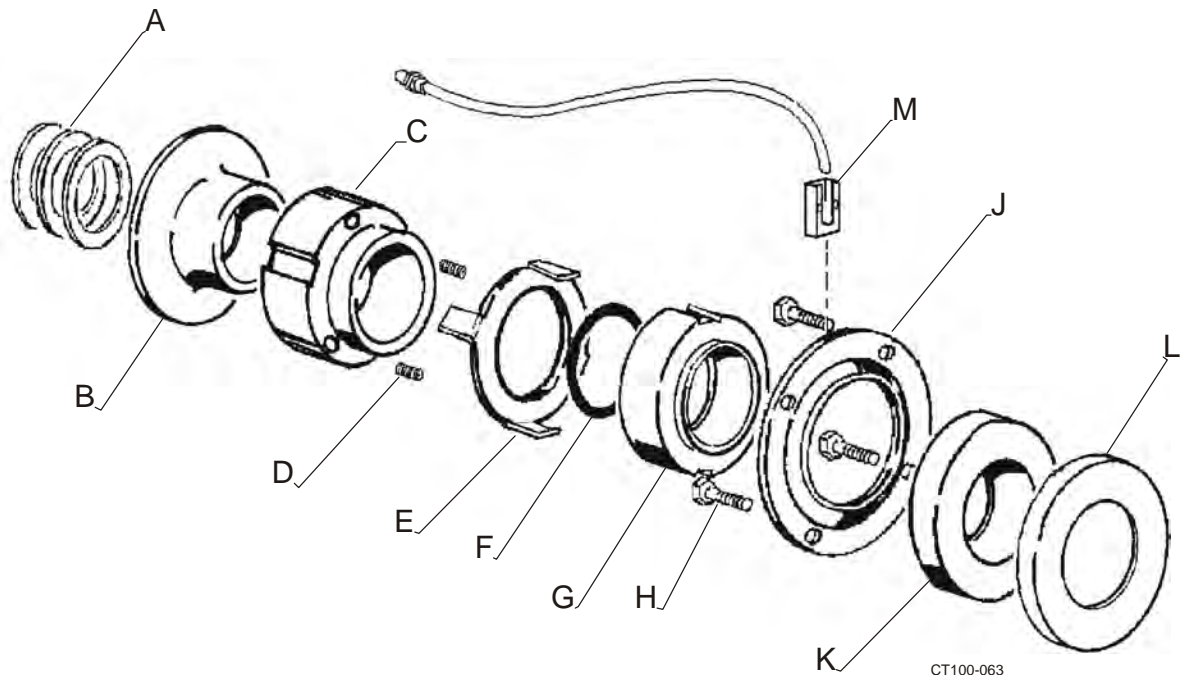

Figure 3 - Type 1 Seal Assembly (Water Cascade Type 1C)

- | | |
|--------------------|------------------------|
| A. Motor Shims | G. Rotary Seal |
| B. Deflector | H. Cap Screws |
| C. Spring Retainer | J. Seat Retainer |
| D. Springs | K. Stationary Seal |
| E. Tabbed Washer | L. L-gasket |
| F. O-ring | M. Water Cascade Block |

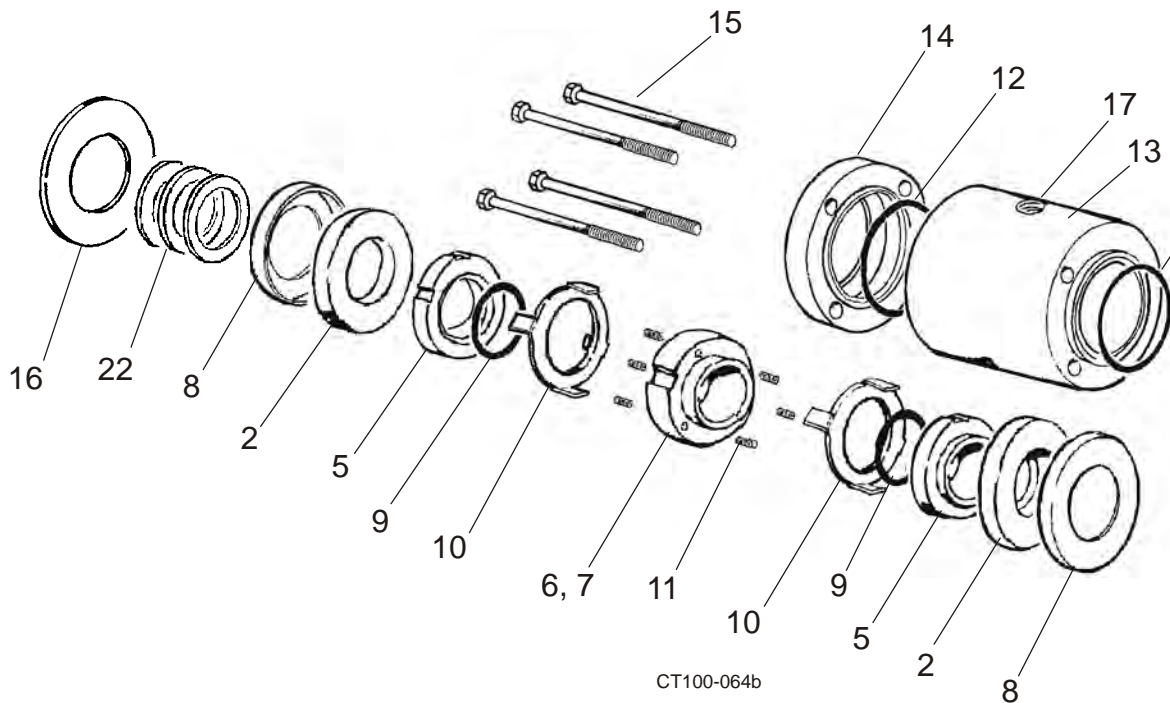

Figure 4 - Type 4 Seal Assembly

- | | |
|--------------------|--------------------|
| 2. Stationary Seal | 12. Housing O-ring |
| 5. Rotary Seal | 13. Seal Housing |
| 6. Set Screw | 14. Seal Retainer |
| 7. Spring Retainer | 15. Cap Screws |
| 8. L-gasket | 16. Slinger |
| 9. Seal O-ring | 17. NPT Plug |
| 10. Tabbed Washer | 22. Motor Shims |
| 11. Springs | |

**Performance
Characteristics****Authorization**

3A/USDA (Sanitary Models)/EHEDG

Standard Construction

- Casing: 316L Stainless Steel
- Port Connections: S-Line
- Backplate: 316L Stainless Steel
- Impeller W/Integral Shaft: 316L Stainless Steel
- Impeller Retainer: 316L Stainless Steel
- Shaft Seal: Single Mechanical, external balanced (Type 1)
- Rotary Seal Material: Carbon
- Stationary Seal: Siliconized Graphite
- Elastomers: FDA approved FKM
- Finish: All product contact surfaces are provided with a sanitary polish (150 Grit). Industrial pumps are unpolished.
The motor adapter bracket is painted with a cast iron paint; a two-part epoxy, TNEMEC 104, Sky-Blue #104-BB-42 on the motor bracket and motor (if ordered).
- Mounting: Close coupled for JM shafted motors

Construction Options**Ports**

Bevel Seat
Female I-Line
Male I-Line
Q-Line
Butt-weld
Female or Male N.P.T
150 Lb. Flange, DIN or SMS

Seal Type

- Water Cascade (Type 1C)
- Double Mechanical w/flush (Type 4 Shaft Seal)
- WFI - Special Type 4 shaft seal for water for injection applications
- Aseptic Shaft Seal - barrier flush design
- Commercially available seals (Contact your WCB representative for details)

Rotary Seal Material

Purebide
Silicone Carbide
Tungsten Carbide

Stationary Seal

Silicone Carbide
Tungsten Carbide

Elastomers

EPDM (FDA approved)
Silicone (FDA approved)
Teflon Encapsulated (FDA approved)
FFKM

Finishes/Product Contact Surfaces

25RA
20RA
Electropolish
Unpolished - Industrial

Leg Kit

See "Motor Mounts" on page 70.

Base Mounting

Footless C-face motors
Footed C-face motors
T-Frame motors

NOTE: T-Frame motors can be configured with or without bases, couplings or coupling covers.

Pedestal Mounted

Two types on stands; see "Base Mount Components" on page 9.

Motors

NEMA JM (standard) totally enclosed fan cooled (TEFC) for close-coupled pumps

1750 or 3500 RPM single phase 115/230 volt and 3 phase 230/460 volt

Optional Enclosures

Washdown
Explosion proof
Severe Duty/Chemical Duty

Operating Parameters**Nominal Capacity**

Up to 1150 U.S. GPM (260 Cubic Meters/Hr.)

Viscosity

Up to 1500 CPS

Differential Pressure

UP to 340 Feet (100 Meters)

Temperature

Up to 450°F (230°C)

Nominal Speeds

1450 or 2900 RPM - 50HZ
1750 or 3500 RPM - 60HZ

Capacities

Sanitary Model	Inlet Size inch (mm)	Maximum impeller Size inch (mm)	Maximum Capacity GPM (M3/HR)
2045	1.5 (40)	4.5 (115)	190 GPM (43)
	2.0 (50)	4.5 (115)	190 GPM (43)
2065LV	1.5 (40)	6.5 (165)	200 GPM (45)
	2.0 (50)	6.5 (165)	200 GPM (45)
	2.5 (65)	6.5 (165)	200 GPM (45)
2065	2.5 (65)	6.5 (165)	400 GPM (91)
2065HV	3.0 (75)	6.5 (165)	500 GPM (114)
2075	3.0 (75)	8.7 (221)	143 GPM (33)
2085LV	2.0 (50)	8.7 (221)	143 GPM (33)
2085	3.0 (75)	8.7 (221)	840 GPM (191)
	4.0 (100)	8.7 (221)	840 GPM (191)
2105	4.0 (100)	10.5 (265)	1400 GPM (318)
	6.0 (150)	10.5 (265)	1400 GPM (318)

Dimensions

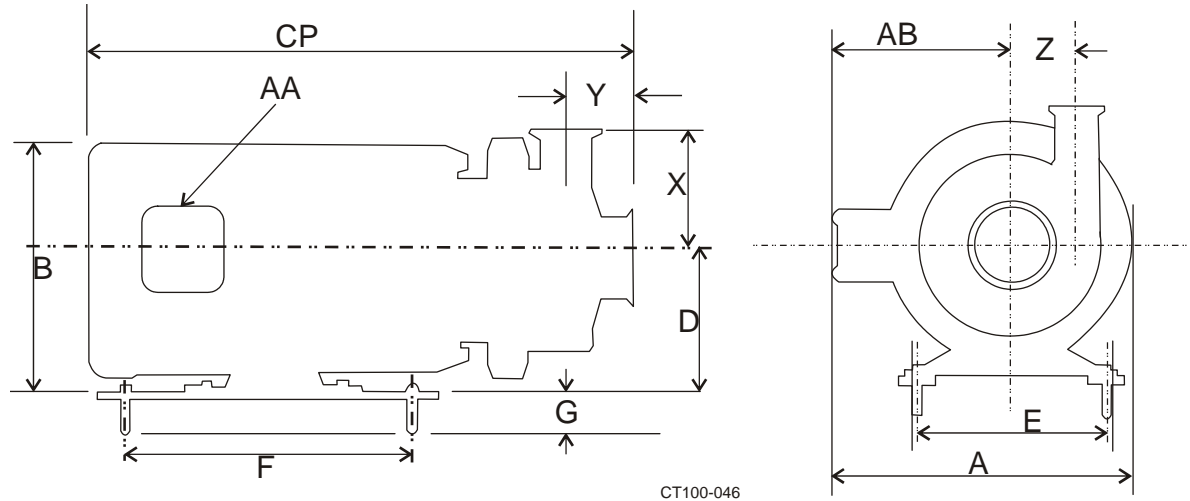

CT100-046

Figure 5 - Footprint Dimensions

Sanitary Model Size (Inlet x Outlet)

Motor Frame	2045 All	2065LV All	2065 2-1/2x2	2065HV 3x2	2085LV 2x1-1/2	2075 2x1-1/2	2085 3x2-1/2	2085 4x2-1/2	2105 4x4	2105 6x4
Dim. Callout	CP inch (mm)	CP inch (mm)	CP inch (mm)	CP inch (mm)	CP inch (mm)	CP inch (mm)	CP inch (mm)	CP inch (mm)	CP inch (mm)	CP inch (mm)
145JM	18.94 (481)	16.35 (415)	16.94 (430)	17.04 (433)	16.16 (410)	16.16 (410)	17.50 (445)	17.05 (433)	--	--
182JM	21.81 (554)	19.66 (500)	20.25 (514)	20.35 (517)	18.09 (459)	18.09 (459)	19.43 (494)	18.96 (482)	--	--
184JM	--	19.66 (500)	20.25 (514)	20.35 (517)	18.09 (459)	18.09 (459)	19.43 (494)	18.96 (482)	25.13 (638)	25.16 (639)
213JM	--	21.91 (557)	22.50 (572)	22.60 (574)	21.72 (552)	21.72 (552)	23.05 (585)	22.55 (573)	23.88 (607)	23.91 (607)
215JM	--	21.91 (557)	22.50 (572)	22.60 (574)	21.72 (552)	21.72 (552)	23.05 (585)	22.55 (573)	26.56 (675)	26.59 (675)
254JM	--	25.47 (647)	26.06 (662)	26.17 (665)	25.53 (648)	25.53 (648)	26.87 (682)	26.43 (671)	27.63 (702)	27.66 (703)
256JM	--	--	27.81 (706)	27.92 (709)	25.53 (648)	25.53 (648)	26.87 (682)	26.43 (671)	29.38 (746)	29.41 (747)
284JM	--	--	--	28.44 (722)	27.66 (703)	27.66 (703)	29.00 (737)	28.50 (724)	29.94 (760)	29.97 (761)
286JM	--	--	--	29.94 (760)	29.16 (791)	29.16 (791)	30.50 (775)	30.00 (762)	31.44 (799)	31.47 (799)
324JM	--	--	--	--	29.97 (761)	29.97 (761)	31.31 (795)	30.81 (782)	31.63 (803)	31.66 (804)
326JM	--	--	--	--	31.47 (799)	31.47 (799)	32.81 (833)	32.31 (821)	32.87 (835)	32.91 (836)

Table of Dimensions

Frame	A inch (mm)	B inch (mm)	D inch (mm)	AA inch (mm)	AB inch (mm)	F inch (mm)	E inch (mm)	G inch (mm)
145JM	8.56 (218)	6.87 (174)	3.5 (89)	.50 (13)	5.25 (133)	12.50 (317)	5.50 (140)	2.00 (51)
182JM	9.81 (249)	8.44 (214)	4.50 (114)	.75 (19)	5.87 (149)	12.50 (317)	7.50 (190)	
184JM	9.81 (249)	8.44 (214)	4.50 (114)	.75 (19)	5.87 (149)	12.50 (317)	7.50 (190)	
213JM	12.18 (309)	10.06 (256)	5.25 (133)	.75 (19)	7.38 (187)	12.50 (317)	8.25 (209)	
215JM	12.18 (309)	10.06 (256)	5.25 (133)	.75 (19)	7.38 (187)	16.0 (406)	8.25 (209)	
254JM	14.68 (373)	12.0 (305)	6.25 (159)	1.0 (25.4)	8.94 (227)	16.0 (406)	10.0 (254)	
256JM	14.68 (373)	12.0 (305)	6.25 (159)	1.0 (25.4)	8.94 (227)	25.5 (648)	10.0 (254)	2.50 (64)
284JM	18.87 (225)	13.63 (346)	7.0 (178)	1.5 (38)	12.25 (311)	25.5 (648)	11.0 (279)	
286JM	18.87 (225)	13.63 (346)	7.0 (178)	1.5 (38)	12.25 (311)	25.5 (648)	11.0 (279)	
324JM	20.75 (527)	15.56 (395)	8.0 (203)	1.5 (38)	13.18 (335)	25.5 (648)	12.5 (317)	
326JM	20.75 (527)	15.56 (395)	8.0 (203)	1.5 (38)	13.18 (335)	25.5 (648)	12.5 (317)	

NOTE: Figure 5 dimensions for the Inlet, Outlet, items X, Y, and Z are listed in "Table of Dimensions" on page 18.

Table of Dimensions

Model (**)	Inlet inch (mm)	Outlet inch (mm)	X inch (mm)	Y inch (mm)	Z inch (mm)
2045	1.5 (40)	1.5 (40)	3.88 (98)	1.81 (46)	2.25 (57)
2045	2.0 (50)	1.5 (40)	3.88 (98)	1.81 (46)	2.25 (57)
2065LV	1.5 (40)	1.5 (40)	4.75 (120)	1.94 (49)	3.19 (81)
2065LV	2.0 (50)	1.5 (40)	4.75 (120)	1.94 (49)	3.19 (81)
2065LV	2.5 (65)	1.5 (40)	4.75 (120)	1.94 (49)	3.19 (81)
2065	2.5 (65)	2.0 (50)	4.44 (113)	1.94 (49)	3.94 (100)
2065HV	3.0 (75)	2.0 (50)	4.44 (113)	1.94 (49)	3.94 (100)
2075	3.0 (75)	1.5 (40)	6.69 (170)	1.75 (44)	4.5 (114)
2085LV	2.0 (50)	1.5 (40)	6.69 (170)	1.75 (44)	4.5 (114)
2085	3.0 (75)	2.5 (65)	5.63 (143)	2.53 (64)	5.06 (129)
2085	4.0 (100)	2.5 (65)	5.63 (143)	2.03 (52)	5.06 (129)
2105	4.0 (100)	4.0 (100)	6.94 (176)	2.86 (73)	6.75 (171)
2105	6.0 (150)	4.0 (100)	6.94 (176)	2.90 (74)	6.75 (171)

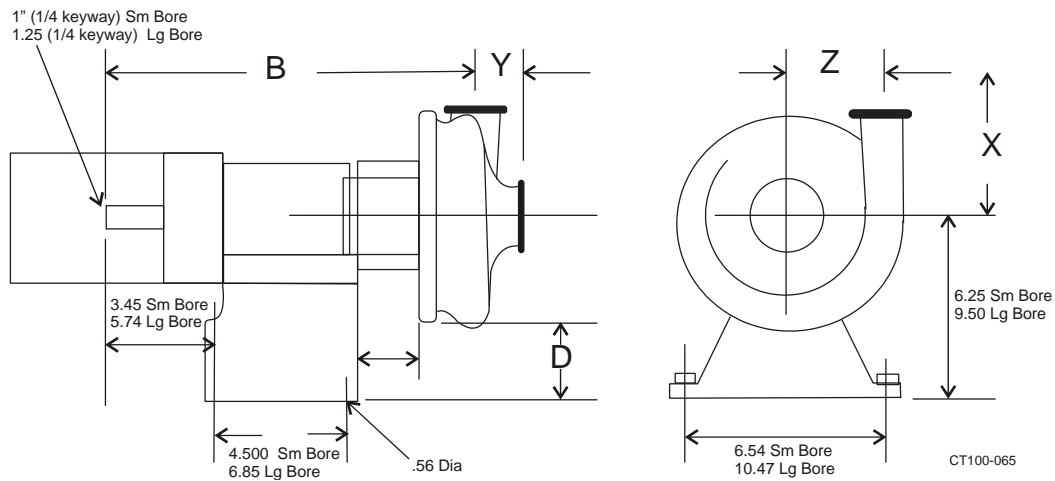

Figure 6 - Style "B" and "C" Less Base Plate

Model	B				D		X inch	Y inch	Z inch
	Inlet inch (mm)	Outlet inch	Sm Bore inch	Lg Bore inch	Sm Bore inch	Lg Bore inch			
P2045	1.5 (40)	1.5 (40)	16.39 (416)	--	3.0 (76)	--	3.88 (98)	1.81 (45)	2.25 (57)
P2045	2.0 (50)	1.5 (40)	16.39 (416)	--	3.0 (76)	--	3.88 (98)	1.81 (45)	2.25 (57)
P2065LV	1.5 (40)	1.5 (40)	16.71 (224)	--	2.0 (50)	5.2 (132)	4.75 (120)	1.94 (49)	3.19 (81)
P2065LV	2.0 (50)	1.5 (40)	16.71 (224)	--	2.0 (50)	5.2 (132)	4.75 (120)	1.94 (49)	3.19 (81)
P2065LV	2.5 (65)	1.5 (40)	16.71 (224)	--	2.0 (50)	5.2 (132)	4.75 (120)	1.94 (49)	3.19 (81)
P2065	2.5 (65)	2.0 (50)	17.30 (439)	--	2.0 (50)	5.2 (132)	4.44 (112)	1.94 (49)	3.94 (100)
P2065HV	3.0 (75)	2.0 (50)	17.93 (455)	21.30 (541)	2.0 (50)	5.2 (132)	4.44 (112)	1.94 (49)	3.94 (100)
P2075	3.0 (75)	1.5 (40)	17.19 (436)	20.42 (581)	1.0 (25)	4.2 (106)	6.69 (176)	1.75 (44)	4.50 (114)
P2085LV	2.0 (50)	1.5 (40)	17.19 (436)	20.42 (581)	1.0 (25)	4.2 (106)	6.69 (176)	1.75 (44)	4.50 (114)
P2085	3.0 (75)	2.5 (65)	18.41 (467)	21.90 (556)	1.0 (25)	4.2 (106)	5.63 (143)	2.53 (64)	5.06 (128)
P2085	4.0 (100)	2.5 (65)	17.91 (454)	21.40 (543)	1.0 (25)	4.2 (106)	5.63 (143)	2.03 (51)	5.06 (128)
P2105	4.0 (100)	--	--	22.57 (573)	--	3.2 (81)	6.94 (176)	2.86 (72)	6.75 (171)
P2105	6.0 (150)	--	--	22.60 (574)	--	3.2 (81)	6.94 (176)	2.90 (73)	6.75 (171)

NOTE: Dimensions X, Y, and B apply to pumps with clamp connections.

Table of Base Size Used On Modular Base Mounted Centrifugal Pumps

Motor HP & RPM	Sanitary Models							
	P2045	P2065LV	P2065	P2065HV	P2075	P2085LV	P2085	P2105
Up to 5HP 1750 RPM	SM.B.	SM.B.	SM.B.	SM.B.	SM.B.	SM.B.	SM.B.	SM.B.
Up to 5HP 3500 RPM	SM.B.	SM.B.	SM.B.					
7½HP 1750 RPM							SM.B.	L.G.B.
7½HP 3500 RPM		SM.B.	SM.B.	SM.B.	SM.B.	SM.B.	SM.B.	
10HP 1750 RPM							SM.B.	L.G.B.
10HP 3500 RPM		SM.B.	SM.B.	SM.B.	SM.B.	SM.B.	SM.B.	
15HP 1750 RPM								L.G.B.
15HP 3500 RPM			SM.B.	SM.B.	SM.B.	SM.B.	SM.B.	
20HP 1750 RPM								L.G.B.
20HP 3500 RPM			SM.B.	SM.B.	SM.B.	SM.B.	SM.B.	
25HP 1750 RPM								L.G.B.
25HP 3500 RPM				L.G.B.				L.G.B.
30HP 1750 RPM								L.G.B.
30HP 3500 RPM				L.G.B.			L.G.B.	
40HP 1750 RPM								L.G.B.
40HP 3500 RPM							L.G.B.	
50HP 1750 RPM								L.G.B.
50HP 3500 RPM							L.G.B.	
60HP 3500 RPM							L.G.B.	
75HP 3500 RPM							L.G.B.	

SM.B. = Small Base

L.G.B. = Large Base

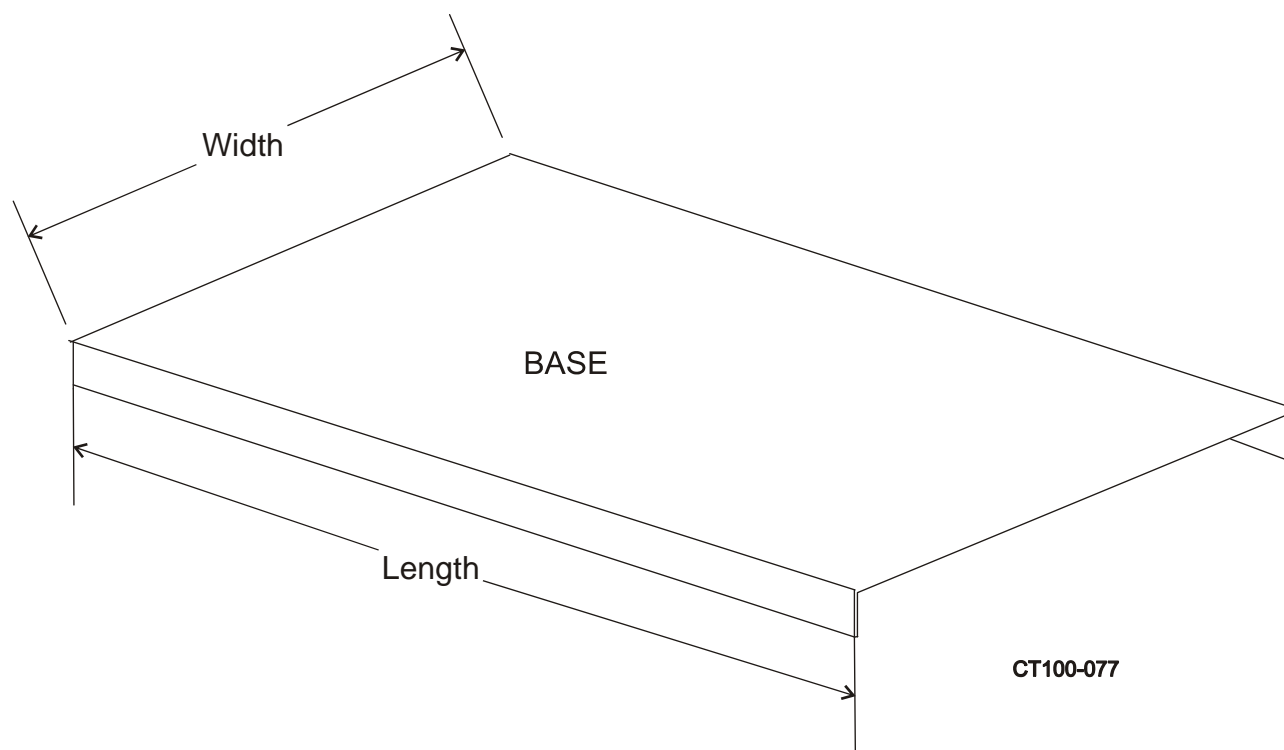

Figure 7 - Base Plate Dimensions for Modular Base-Mounted Centrifugal Pumps

Base plates (optional) are provided in three widths and five lengths (depending on motor frame and pump model).

Widths Available:

10 inches
15 inches
18 inches

Lengths Available:

20 inches (Style A Only)
24 inches
32 inches
38 inches
50 inches

Centrifugal 200 Series Pump and Pedestal Weights

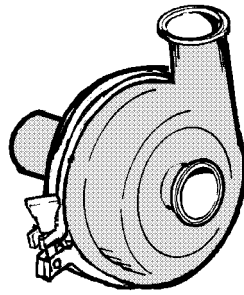

Figure 8 - Close-Coupled Pump (Less Motor and Legs)

Motor Frame	Pump Model							
	2045 LBS (KG)	2065LV LBS (KG)	2065 LBS (KG)	2065HV LBS (KG)	2075 LBS (KG)	2085LV LBS (KG)	2085 LBS (KG)	2105 LBS (KG)
142-184JM	21 (9.5)	31 (14)	33 (14.9)	35 (15.8)	57 (25.8)	57 (25.8)	51 (23.1)	60 (27.2)
213-215JM	35 (15.8)	37 (16.7)	39 (17.6)	60 (27.2)	54 (24.4)	54 (24.4)	78 (35.3)	--
254-256JM	37 (16.7)	39 (17.6)	41 (18.5)	63 (28.5)	57 (25.8)	57 (25.8)	79 (35.8)	--
284-326JM	51 (23.1)	53 (24)	71 (32.2)	64 (29)	82 (37.1)	82 (37.1)	--	--

Add 5LB. For Pumps With Double Seals

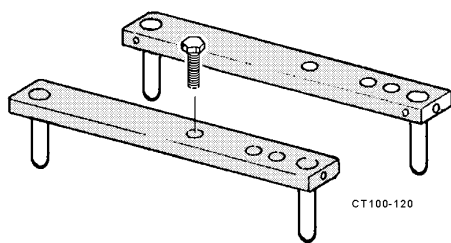

Figure 9 - Legs

Add Listed Weight for Legs

Motor Frame	Weight IBS (KG)
142-213JM	10.5 (4.7)
215-254JM	12.5 (5.6)
254-326JM	42.5 (19.2)

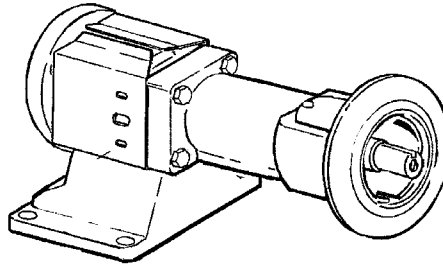

Figure 10 - Pedestal Pump (Less Base and Motor)

Pump Model								
PEDESTAL	2045 lbs (KG)	2065LV lbs (KG)	2065 lbs (KG)	2065HV lbs (KG)	2075 lbs (KG)	2085LV lbs (KG)	2085 lbs (KG)	2105 lbs (KG)
SMALL BORE	92 (41)	106 (48)	108 (48.9)	110 (49.8)	131 (59.4)	131 (59.4)	125 (56.6)	--
LARGE BORE	--	--	--	--	--	--	235 (106.5)	240 (108.8)

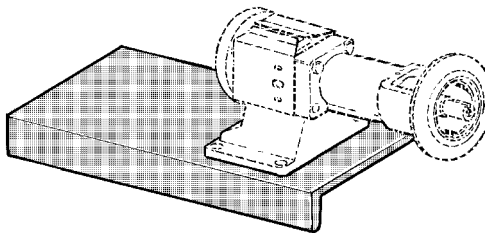

Figure 11 - Base Weight (add to Pedestal Weight)

MOTOR	SMALL BORE LBS (KG)	LARGE BORE LBS (KG)
48	30 (13.6)	--
56	30 (13.6)	--
143/145T	31 (14.6)	--
182/184T	32 (14.5)	50 (22.6)
213/215T	33 (14.9)	50 (22.6)
254/256T	40 (18.1)	52 (23.5)
284/286T	35 (15.8)	62 (28.1)
284/286TS	--	64 (29.0)
324/326T	--	65 (29.4)
324/326TS	--	65 (29.4)
364TS	--	65 (29.4)

Installation

Pump Location

Consider the following when determining a location for the installation of your pump:

- Locate the pump as near as is practical to the liquid supply.
- Keep the supply piping short and straight to keep the pump supplied with liquid and prevent damaging cavitation.
- Make sure the pump is accessible for service and inspection during operation.
- Protect the motor from flooding.

Pump Leveling

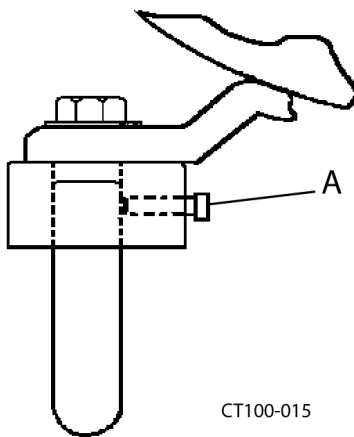

CT100-015

Figure 12 - Leveling Leg Set Screw Location

Level the pump by loosening the set screws (Figure 12, item A) to adjust the length of the legs.

Supply and Discharge Piping/Valves

Consider the following when determining supply/discharge piping and valve installation of your pump:

- Use a line size equal to or larger than the connection size on the pump, especially the inlet supply line.
- Keep the supply line as short and straight as possible and use as few elbows, valves, or other types of restriction as possible. Avoid up and down rises which will trap air.
- Be certain all joints in the suction line are well-sealed to prevent air leaks.
- Maintain a straight length of pipe (Figure 13, item A) at least 8 diameters long at the pump inlet.

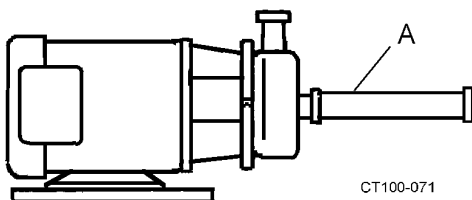

CT100-071

Figure 13 - Straight Pipe Length

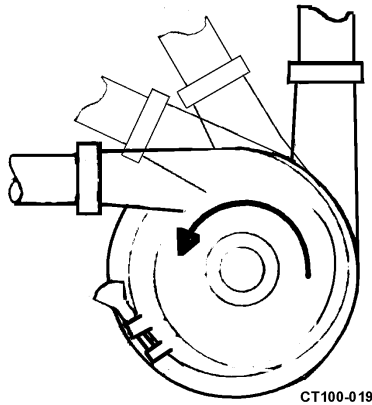

Figure 14 - Recommended Discharge Positions

- The pump casing may be rotated with the discharge connection pointing in any direction. The best pump performance will be with the outlet up, to the left, or positions in between; these positions ensure a flooded casing and prevent problems caused by air in the system (Figure 14).
- All joints in the suction line must be well-sealed to prevent air from being sucked into the system.

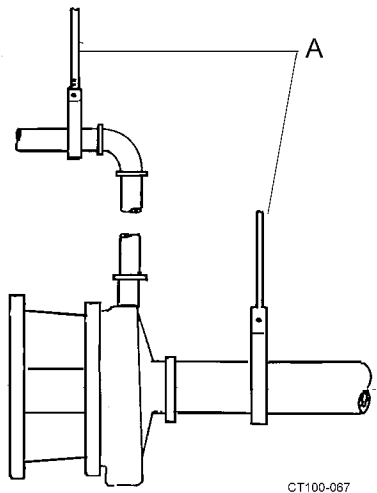

Figure 15 - Pipe Supports

- Support the supply and discharge piping near the pump so that no strain is put on the pump casing.
- If an expansion joint is used, install a pipe anchor between the joint and the pump.
- If a reducer is connected to an inlet, use an eccentric-type reducer to prevent problems caused by trapped air (Figure 16).



CAUTION: The pump and piping may contain sharp edges. Wear gloves while installing and servicing the pump to help avoid injuries from these hazards.

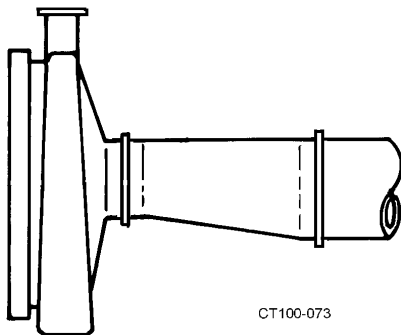

Figure 16 - Correct Eccentric Installation

- The line slope will depend on application requirements; the best pump operation is with the supply line sloped slightly upward toward the pump to prevent trapping air. If the system must drain into the pump casing, keep the downward slope to a minimum or priming problems may occur.
- Install shutoff valves to isolate the pump from the supply and discharge lines. This will allow the pump to be serviced without draining the system.

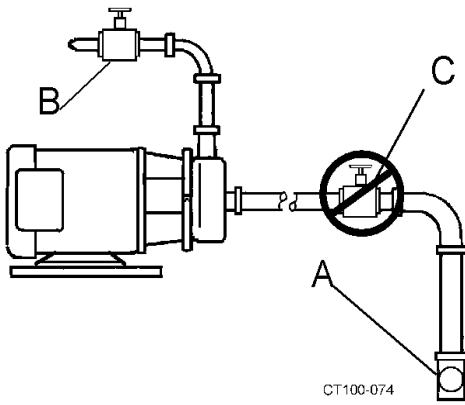

Figure 17 - Valve Piping Installation

Installations That May Cause Operation Problems

- This pump is not self priming. If the pump is installed above the supply liquid level, install a foot valve or other system check valve to keep the system flooded for priming (Figure 17, item A)
- A throttling valve may be required to control the pump flow rate to prevent motor overload. Always install the throttling valve (Figure 17, item B) in the discharge piping, at least 10 pipe diameters from the pump outlet.
- **Never** install a throttling valve in the supply piping (Figure 17, item C).
- Any system throttling valves or similar devices to control the flow rate must be installed in the discharge line. **Do not** install any system throttling valves or similar devices to control the flow rate in the supply line. Restriction in the supply line may cause cavitation and pump damage.
- “Water hammer” in the system can damage the pump and other system components. Water hammer often occurs when valves in the system are suddenly closed, causing lines to move violently and with a loud noise. When this condition is present, find and eliminate the source of the water hammer. One way to eliminate water hammer is to slow down the actuation speed of the valve.
- Do not expose the pump to freezing temperatures with liquid in the casing. Frozen liquid in the casing will damage the pump. Drain the casing before exposing it to freezing temperatures.

Electrical Connections



WARNING: To avoid electrocution, ALL electrical installation should be done by a registered Electrician, following Industry Safety Standards. All power must be OFF and LOCKED OUT during installation.



Figure 18 - Direction of Motor Rotation

- Read the motor manufacturer's instructions before starting the installation. Follow the manufacturer's lubrication schedules.
- Check the motor nameplate to be sure the motor is compatible with the electrical supply and all wiring, switches, and starters. Make sure all overload protections are correctly sized (Figure 18).
- Check the pump rotation following the electrical installation. The correct rotation is counterclockwise when facing the pump inlet connection (Figure 14 and Figure 18).

Flush Seal Option

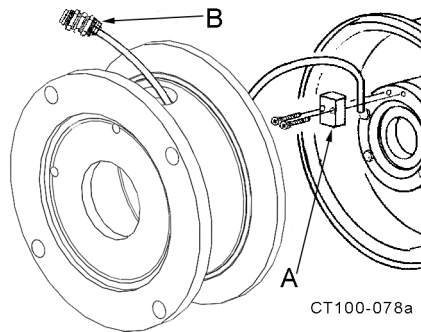

Figure 19 - Cascade System Installation

When this option is ordered, a fitting assembly (Figure 19, item A) is supplied for directing a flow of water onto the backplate/seal area.

- The water cascade block must be above the seal on the assembled backplate to flow water onto the seal face.
- The connection (Figure 19, item B) is 1/4 inch O.D. tubing.
- The required flow is approximately 5 U.S. gallons per hour.
- The recommended water supply is cool and filtered. If the product solidifies at a cool temperature, warm or hot water can be used.

NOTE: To prevent hose contact with the rotating shaft and seal parts during operation, pull the excess hose to the outside of the adapter.

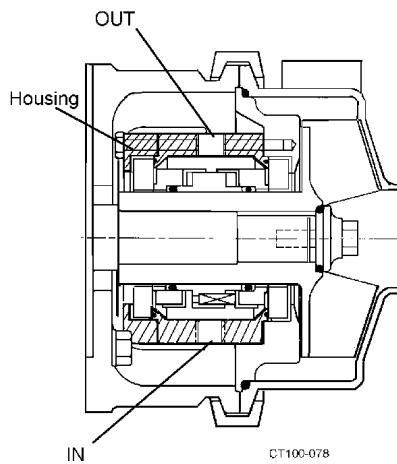

Figure 20 - Type 4 Flush Housing

Type 4 Seal (Double mechanical with flush)

Attach the seal flush supply to the bottom 1/4-inch pipe-threaded hole in the flush housing. The drain tubing attached to the top hole allows moderate pressure to be supplied to the seals and allows continuous flooding. (Figure 20).

Before First Startup

Cleaning Safety Procedures

Clean Pump and Piping

Disassemble the pump and clean all product contact parts and seal parts prior to the first operation. Follow the instructions in the “Cleaning Safety Procedures,” below and “Routine Maintenance” on page 32. Thoroughly clean the pump of any materials which could have accumulated during installation.

Manual Cleaning

Address the following recommendations when manually cleaning your pump:

- Do not use toxic and/or flammable solvents.
- Lock out electrical power and shut off all air prior to cleaning the equipment.
- Keep electrical panel covers closed and power off when washing the equipment.



WARNING: To prevent an accidental start-up, lock out the power source with lock and key.

- Clean up spills as soon as possible.
- Never attempt to clean the equipment while it is operating.
- Wear proper protective clothing.

Cleaning-In-Place (CIP)

When performing CIP:

1. Make certain that all connections in the cleaning circuit are properly applied and tight to avoid contact with hot water or cleaning solutions.
2. When the cleaning cycle is controlled from a remote or automated cleaning center, establish safe procedures to avoid automatic start-up while servicing equipment in the circuit.

NOTE: Always replace the o-rings when reassembling the pump. If the area behind these seals becomes soiled, contact WCB Application Engineering for a specific cleaning and sanitizing procedure validated to remove bacteria.

Preliminary Test Run

Test the system using a preliminary run with the materials that will be pumped. **DO NOT** run the pump at this time to produce final product.

See “Starting the Pump” on page 30.

Check For Possible Motor Overload Conditions

Certain combinations will overload the motor when operated with open unrestricted discharge, resulting in an unacceptably high flow rate. Additional discharge restriction may be required to lower the flow rate and lower the horsepower requirement. **DO NOT** add a restriction to the supply line. If the pump was incorrectly selected, a smaller impeller or a higher motor horsepower may be required.

If you are uncertain about pump selection and application, temporarily install an ammeter in the electrical service.

Ammeter Test



WARNING: To avoid electrocution and equipment damage, only a qualified electrician should install the ammeter.

Operate the pump under process conditions and check the motor amp draw versus the nameplate full load rating. If the amp draw exceeds the motor rating, a system change or pump change is required.

If the process conditions and/or liquid changes (higher viscosity, higher specific gravity), recheck the motor amp draw.

Operation

Before proceeding, make sure your pump has been correctly installed as described in "Installation" on page 24.

Starting the Pump

1. If the pump has a flush seal option, start the flow of flush water (approximately 5 US gallons per hour recommended rate) before operating the pump.
2. **Before** starting the pump, prime the pump by flooding the pump casing with liquid, to avoid damage to pump parts. See "Priming the Pump With the Feed Source Above Pump Level" on page 30 or "Priming the Pump With the Feed Source Below Pump Level" on page 31.
3. Start the pump motor.
4. Check the pump to see that liquid is flowing and that all piping connections and seals are leak-free.
5. Make sure that the pump is not operating against a closed discharge. Continued operation against a closed discharge will heat the liquid in the casing to boiling and lead to pump damage.
6. Slowly open the discharge valve until the desired flow is obtained. Observe the pressure gauges and if pressure is not attained quickly, stop the pump and prime it again.

Priming the Pump/ Stopping the Pump

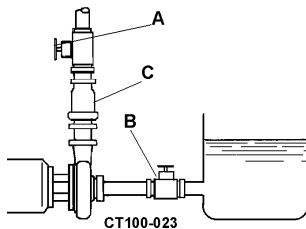

**Figure 21 - Pump Below Supply
(Feed Source Above Pump Level)**

Priming the Pump With the Feed Source Above Pump Level

1. Fill the supply tank with liquid; open the supply line (suction) valve (Figure 21, item B).
2. Vent any air trapped in the supply line or casing by opening the discharge valve (Figure 21, item A).
3. Start the pump.

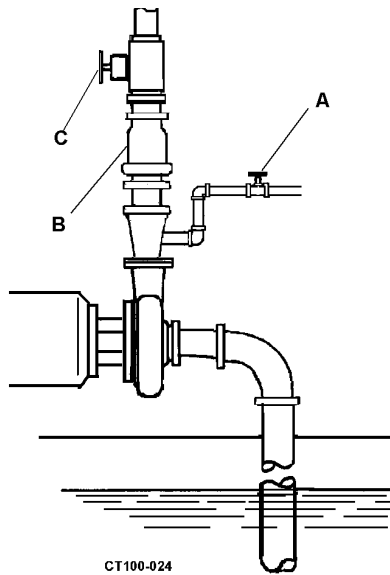

**Figure 22 - Pump Above Supply
(Feed Source Below Pump Level)**

Priming the Pump With the Feed Source Below Pump Level

The pump will not self-prime if the liquid supply is below the pump level. When the liquid supply is below the pump level, an outside source must be provided for priming.

1. Close the discharge valve (Figure 22, item C) and open the air vents.
2. Open the valve installed in the outside supply line (Figure 22, item A) until liquid flows from vent valves.
3. Close the vent valves.
4. Close the outside supply line.

NOTE: Use a check valve system (Figure 22, item B) to keep the supply line and pump casing flooded with liquid; otherwise the pump must be primed before each operation.

Stopping the Pump

1. To stop the pump, shut off power to the pump motor.

NOTE: Liquid in the system can flow freely through the pump; the pump does not act as a shutoff valve.

2. Shut off supply and discharge lines.

Maintenance

Scheduled Maintenance

A routine maintenance program can extend the life of your pump. Make sure to keep maintenance records. These records will help pinpoint potential problems and causes.

Routine Maintenance

Your scheduled routine maintenance should include the following items:

- Check for unusual noise, vibration, and bearing temperatures
- Inspect the pump and piping for leaks
- Check the Mechanical Seal area for leakage (No leakage is desired)
- Check the backplate gasket for wear/damage
- Bearing lubrication (See motor manufacturer for correct specifications)
- Seal Monitoring
- Vibration analysis
- Check the discharge pressure
- Temperature monitoring

Disassembly of Pump With a Type 1 Seal

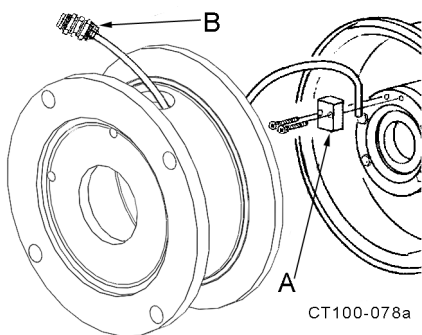

Figure 23 - Removal of the Water Cascade System

1. Shut off the product flow to the pump and relieve any product pressure.
2. Shut off and lock out power to the pump.
3. Disconnect the suction and discharge pipe fittings.
4. Remove the casing clamp and casing.
5. Slide the o-ring off of the backplate.
6. Remove the impeller retainer bolt and shaft o-ring.

NOTE: The retainer bolt has standard right-hand threads.

Removal of the Water Cascade

1. Loosen the socket head screws holding the water cascade block on the stationary seat retainer and remove the plastic hose.
2. Pull off the impeller/backplate assembly and place it on a clean flat surface with the impeller shaft up.



CAUTION: Handle the impeller/backplate assembly with care to prevent damage to the seal components.

NOTE: If the assembly cannot be removed from the motor shaft by hand, contact Waukesha Cherry-Burrell Customer Service.

3. Locate the shims on the motor shaft and remove them.

NOTE: Motor shaft shims may fall off the motor shaft or hang up inside the deflector. **Be sure to place all shims back on the motor shaft.**

4. Remove the deflector (Figure 24, item B).
5. Loosen the two (2) set screws (Figure 24, item D) in the spring retainer (item C) and slide the retainer and washer (item F) off the shaft. Save the three (3) springs (item E).

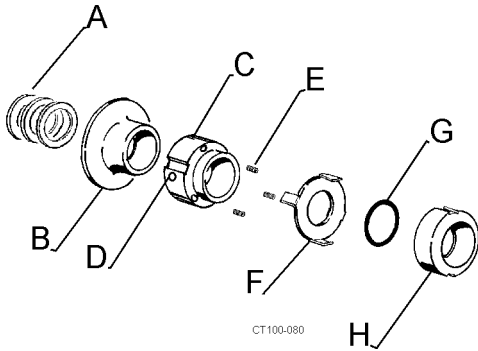

Figure 24 - Type 1 Seal Items

6. Use the backplate to slide the rotary seal up the impeller shaft approximately 1-1/2 inches (Figure 25).



Figure 25 - Moving Rotary Seal Up the Shaft

7. With the backplate resting on the impeller, push the rotary seal toward the backplate until the o-ring is free (Figure 26).
8. Remove the o-ring, then lift the rotary seal off the shaft (Figure 24, items G and H).
9. Lift the backplate off the impeller.



CAUTION: To avoid seal failure, DO NOT place fingers on the carbon seal face.



Figure 26 - Push Rotary Seal Down

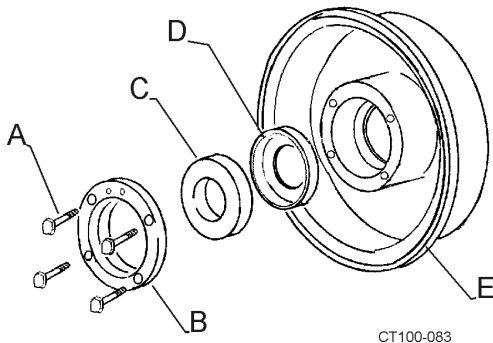

Figure 27 - Removing Stationary Seal

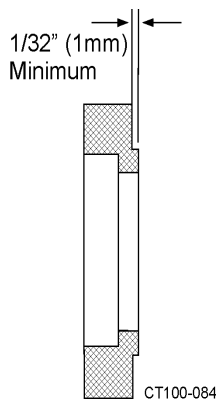

Figure 28 - Rotary Seal Replacement Minimum

Assembly of Pump With a Type 1 Seal

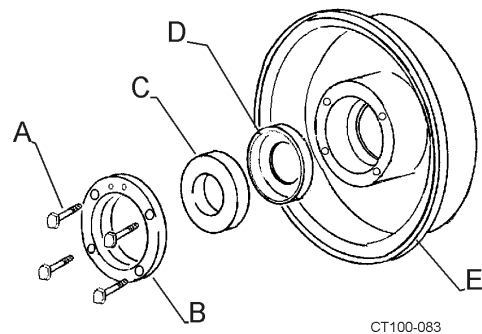

Figure 29 - Stationary Seal Assembly

10. Remove the four 1/4" hex bolts and stationary seat retainer ring (Figure 27, items A and B).
11. Pull the stationary seal and L-gasket out of the backplate (Figure 27, items C and D).

NOTE: The stationary seal is brittle. Prying or hammering on the seal plate can shatter the seal. If the stationary seal cannot be removed by hand, place a 2-1/4 inch diameter plastic or wood rod on the impeller side of the seal and apply even pressure to dislodge the seal.

Inspect Parts

Once disassembly is complete, perform the following inspections:

- Examine all seal surfaces and replace seals that are scratched, cracked and/or braised.
- Inspect all o-rings and o-ring seats for abrasions, cuts or other wear that could cause leakage.
- Clean all seat areas and alignment surfaces.

NOTE: Stationary seals are **reversible**. Use **both sides** before replacing them.

NOTE: Replace the rotary seal when the seal face extends less than 1/32 inch (1 mm) from the body (Figure 28).

Backplate Assembly

1. Lightly lubricate both sides of the L-gasket (Figure 29, item D) with a sanitary lubricant and insert it into the backplate seal cavity.
2. Place the stationary seal into the L-gasket (Figure 29, items C and D).
3. Place the seat retainer over the stationary seal and secure the retainer with four 1/4-20 x 1/2 inch hex head cap screws (Figure 29, items B and A).
4. Tighten the cap screws evenly.

Backplate/Impeller Assembly

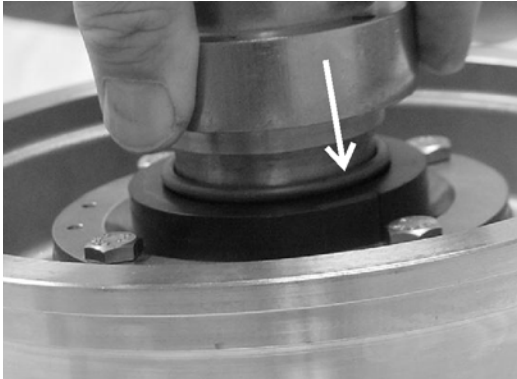

Figure 30 - Installing O-ring Using Spring Retainer

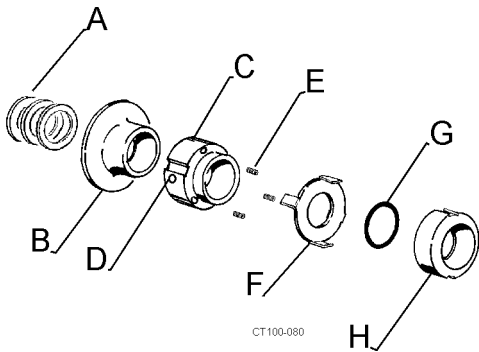

Figure 31 - Type 1 Seal Assembly

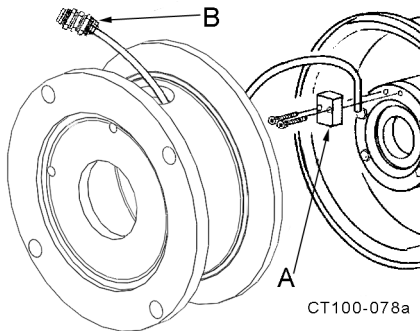

Figure 32 - Installing Water Cascade System

1. Place the impeller on a clean flat surface, shaft-end up, and slide the assembled backplate onto the impeller shaft.

NOTE: Avoid hitting the stationary seal against the impeller shaft, as it could break the seal.

2. Carefully place the rotary seal in position over the impeller shaft and down against the stationary seal.
3. Lubricate and slide the seal o-ring onto the impeller shaft. Use the spring retainer as a tool to push the o-ring into the rotary seal (Figure 30).
4. Slide the tabbed washer (Figure 29, item F) over the impeller shaft and engage the tabs of the washer into notches on the outside of the rotary seal (Figure 31, items F and H).
5. Install the three seal springs into the holes in the spring retainer (Figure 31, items C and E). Hold the springs in place with RTV silicone sealant.
6. Slide the spring retainer over the impeller shaft until the slots in the spring retainer engage the drive tabs on the washer and the springs rest against the washer (Figure 31).
7. With the backplate against the impeller, push the spring retainer down to compress the springs until the length of visible spring is approximately 1/8".
8. Lock the spring retainer in place by tightening the set screws (Figure 31, item D).
9. Install the deflector onto the impeller shaft (Figure 31, item B).
10. If your system has a water cascade, thread the water cascade hose through the adapter and install the cascade block on the backplate (Figure 32, items A and B).
11. Slide the motor shims onto the shaft. Use the same number of shims that were removed when the pump was disassembled.
12. Install the impeller assembly on the stub shaft of the motor.
13. Hand-tighten the impeller retainer bolt on the shaft.

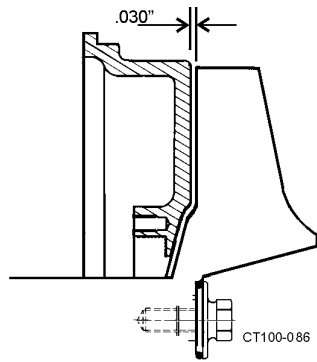

Figure 33 - Clearance Between Impeller and Backplate

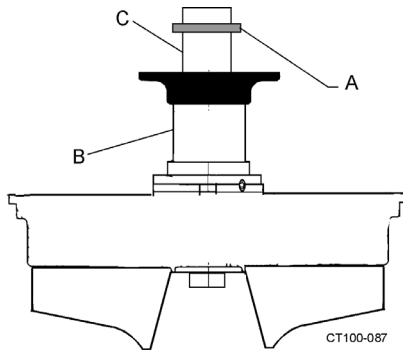

Figure 34 - Locations of Shims

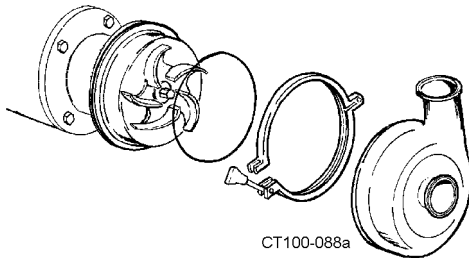

Figure 35 - Install Casing

14. Check the space between the back of the impeller and the backplate with a feeler gauge (0.030" nominal) while holding the backplate tight against the bearing housing flange. (Any axial movement of the shaft should not be added to the 0.030" nominal clearance) (Figure 33). If needed, change this clearance by adding or removing shims. Shims (Figure 34, item A) are added on the drive shaft (Figure 34, item C) behind the impeller shaft (Figure 34, item B).

15. Confirm the operating clearances by clamping the casing to the bearing housing flange and rotating the shaft/impeller manually to be sure the impeller does not touch the casing or backplate.

16. When the proper shim pack is confirmed, remove the casing, impeller, and backplate, leaving the shim pack on the shaft.

17. Remove the backplate/impeller assembly and apply anti-seize or equal compound to the motor shaft and install the key.

NOTE: Always replace the o-rings and L-gasket when reassembling the pump. If the area behind these seals becomes soiled, contact WCB Application Engineering for a specific cleaning and sanitizing procedure validated to remove bacteria.

18. Install the casing o-ring on the backplate and clamp the casing in place (Figure 35).

NOTE: Rotate the impeller manually to ensure it does not rub on the backplate or casing.

Type 4 Double Seal

The Type 4 Seal is essentially two Type 1 seals assembled back to back in a chamber which bolts to the backplate in place of the stationary seat retainer. Except for the additional components (chamber, seals), Type 1 and Type 4 components are interchangeable (Figure 36).

Disassembly of Type 4 Seal

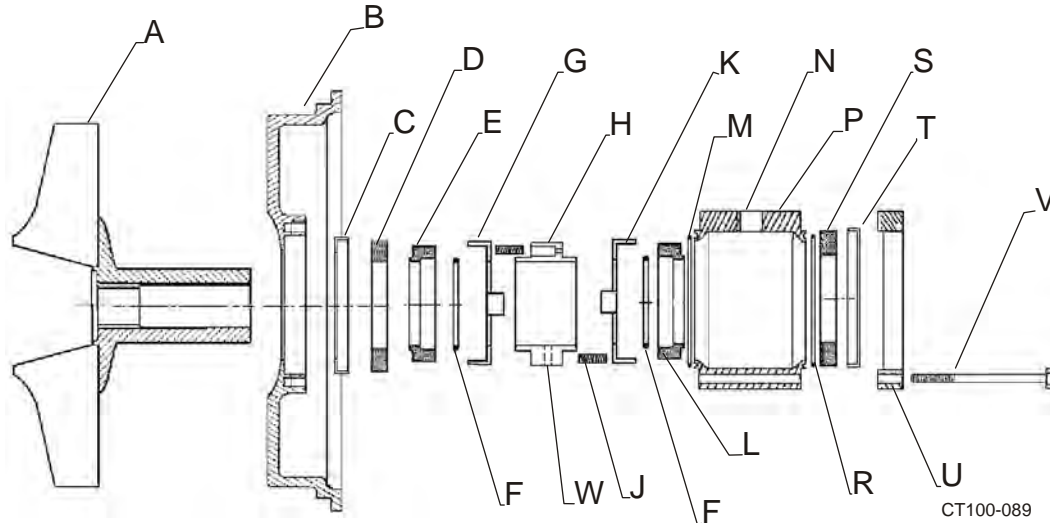

Figure 36 - Type 4 Seal Components

A. Impeller	F. O-ring	L. Rotary Seal	S. Stationary Seal
B. Backplate	G. Washer	M. O-ring	T. L-gasket
C. L-gasket	H. Spring Retainer	N. NPT Port	U. Seat Retainer
D. Stationary Seal	J. Spring	P. Flush Housing	V. Hex Head Screw (4)
E. Rotary Seal	K. Washer	R. O-ring	W. Set Screw



CAUTION: Handle the impeller/backplate assembly with care to prevent damage to the seal components.

1. Shut off the product flow to the pump and relieve any product pressure.
2. Shut off and lock out power to the pump.
3. Disconnect the suction and discharge pipe fittings.
4. Remove the casing clamp and casing. Slide the o-ring off the backplate.
5. Remove the impeller retainer bolt and shaft o-ring.

NOTE: The retainer bolt has standard right-hand threads.

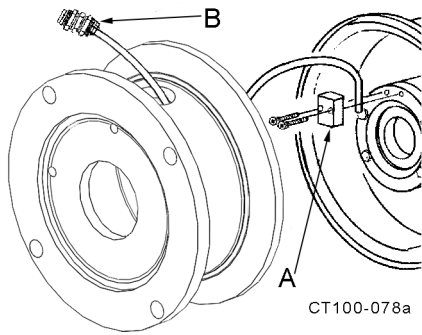

Figure 37 - Removal of Water Cascade System

CAUTION: Handle the impeller/backplate assembly with care to prevent damage to the seal components.



Figure 38 - Move Rotary Seal Up Shaft



Figure 39 - Push Rotary Seal Down

Removal of the Water Cascade

If your system is equipped with a water cascade system, remove it before proceeding.

1. Loosen the socket head screws holding the water cascade block on the stationary seat retainer and remove the plastic hose.
2. Pull off the impeller/backplate assembly and place it on a clean flat surface with the impeller shaft facing up.

NOTE: If the assembly cannot be removed from the motor shaft by hand, contact Waukesha Cherry-Burrell Customer Service.

3. Locate the shims on the motor shaft and remove them.

NOTE: Motor shaft shims may fall off the motor shaft or hang up inside the deflector. **Be sure to place all shims back on the motor shaft.**

4. Place the impeller assembly **face down** (on impeller vanes) and remove the hex head screws (Figure 36, item V) from the back of the seal assembly.
5. Carefully lift off the seat retainer, o-ring, L-gasket, stationary seal, and flush housing (Figure 36, items P, R, T, S and U).
6. Loosen (2) set screws in the spring retainer (Figure 36, items W and H).
7. Lift off rotating seal components See Figure 36:
 Rotary Seal (item L)
 O-ring (item M)
 Washer (item K)
 Spring Retainer (item H)
 Springs (there are six springs, 3 up and 3 down) (item J)
 Washer (item G)
8. Use the backplate to slide the rotary seal up the impeller shaft approximately 1-1/2 inches (Figure 38).
9. With the backplate resting on the impeller, push the rotary seal toward the backplate until the o-ring is free (Figure 39).
10. Remove the stationary seal and L-gasket from the backplate. (Figure 40, items D and C)

NOTE: The stationary seal is brittle. Prying or hammering on the seal plate can shatter the seal. If the stationary seal cannot be removed by hand, place a 2-1/4 inch diameter plastic or wood rod on the impeller side of the seal and apply even pressure to dislodge the seal.

11. Inspect and replace all damaged and worn parts.

Assembly of Type 4 Seal

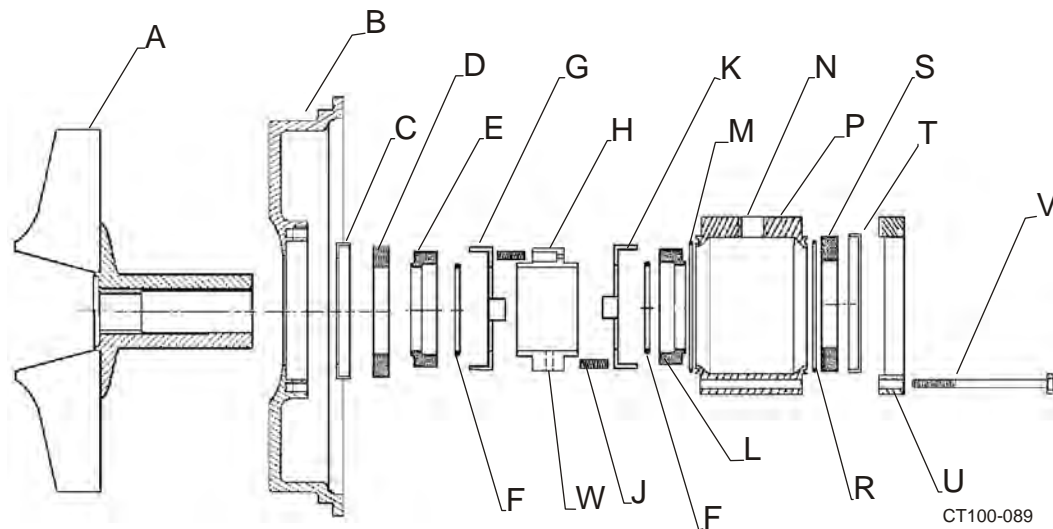

Figure 40 - Type 4 Seal Components

A. Impeller	F. O-ring	L. Rotary Seal	S. Stationary Seal
B. Backplate	G. Washer	M. O-ring	T. L-gasket
C. L-gasket	H. Spring Retainer	N. NPT Port	U. Seat Retainer
D. Stationary Seal	J. Spring	P. Flush Housing	V. Hex Head Screw (4)
E. Rotary Seal	K. Washer	R. O-ring	W. Set Screw



CAUTION: Handle the impeller/backplate assembly with care to prevent damage to the seal components.

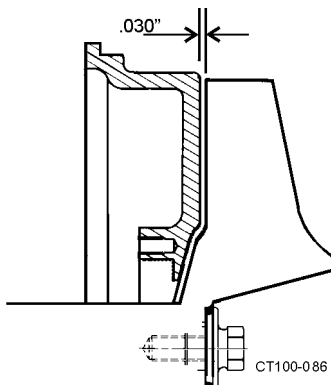

Figure 41 - Shim Placement

1. Clean all parts and lubricate all elastomer (rubber-like) parts.
2. Install the L-gasket in the backplate (Figure 40, items B and C).
3. Install the L-gasket in the seat retainer (Figure 40, item T).
4. Install the stationary seals (Figure 40, item S) in the L-gaskets.
5. Place the backplate and rotary seal onto the impeller shaft.
6. Temporarily put 0.03" shims between the impeller vane and back plate to a preset clearance. **Be sure to remove the shims before final assembly** (Figure 41).
7. Place the o-ring (Figure 40, item F) on the shaft and use the spring retainer to push the o-ring into the rotary seal (Figure 42).
8. Place the washer (Figure 40, item G) over the rotary seal with tabs in the outside diameter notches.
9. Place three springs (Figure 40, item J) in one side of the spring retainer (item H). Hold them in place with silicone sealer, and slide the spring retainer (with the springs down) onto the impeller shaft the against the washer.

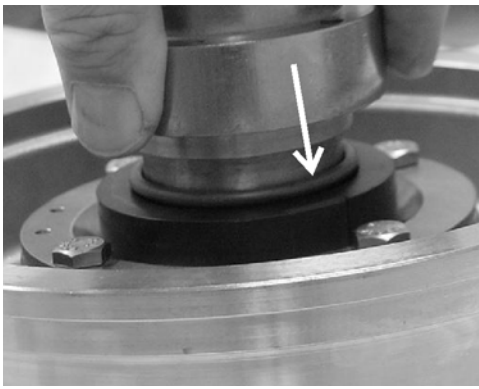

Figure 42 - Installing O-ring Using Spring Retainer

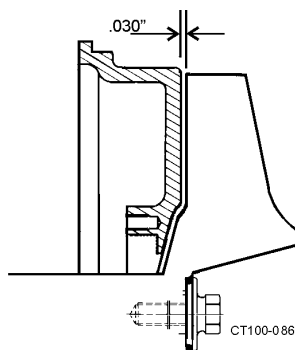

Figure 43 - Clearance Between Impeller and Backplate

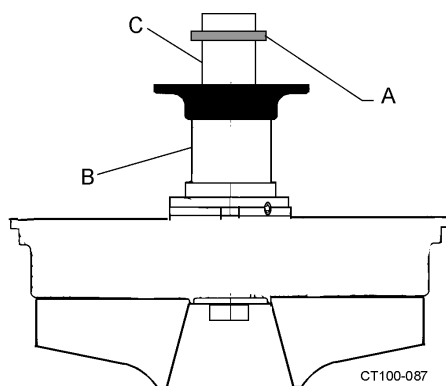

Figure 44 - Locations of Shims

10. Place the remaining three (3) springs in the spring retainer.
 11. Slide the washer and o-ring (Figure 40, items K and F) onto the shaft against the spring retainer.
 12. Use the spring retainer to press the o-ring into the rotary seal.
 13. Remove the 1/4 NPT plug from the center port on the flush housing (Figure 40, item N).
 14. Install an o-ring (Figure 40, items M and R) in both ends of the housing.
 15. Install the L-gasket in the seat retainer (Figure 40, items T and U).
 16. Install the stationary seal (Figure 40, item S) in the L-gasket.
 17. Install the housing over the seal assembly.
 18. With flush ports facing away from the backplate, place the seat retainer (Figure 40, item U) on the housing.
 19. Tighten the seat retainer in place with four (4) hex screws (Figure 40, item V).
- NOTE:** Be sure to tighten the screws evenly until full metal-to-metal contact is made on the backplate and seat retainer.
20. Install the original shims on the motor adapter shaft.
 21. Install the backplate with the seal assembly and impeller on the motor shaft.
 22. Check the impeller/backplate clearance with the backplate held firmly in position against the motor adapter. Check the space between the back of the impeller and the backplate with a feeler gauge (0.030" nominal) while holding the backplate tight against the bearing housing flange. Any axial movement of the shaft should not be added to the 0.030" nominal clearance (Figure 43). If needed, change this clearance by adding or removing shims. Shims (Figure 44, item A) are added on the drive shaft (Figure 44, item C) behind the impeller shaft (Figure 44, item B).
 23. Confirm the operating clearances by clamping the casing to the bearing housing flange and rotating the shaft/impeller manually to be sure the impeller does not touch the casing or backplate.
 24. Tighten the set screws in the spring retainer through the 1/4" NPT center port in the flush housing (Figure 40, item N).
 25. Insert the plug in the port and tighten it.
 26. Remove the backplate/impeller assembly and apply anti-seize or equal compound to the motor shaft and install the key.
 27. Install the backplate/impeller assembly and lock it in place using the o-ring and impeller retainer bolt.

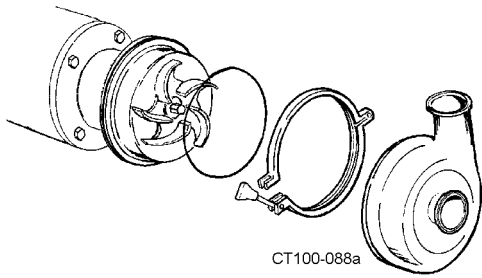

Figure 45 - Install Casing

NOTE: Always replace the o-rings and L-gasket when reassembling the pump. If the area behind these seals becomes soiled, contact WCB Application Engineering for a specific cleaning and sanitizing procedure validated to remove bacteria.

28. Install the casing o-ring on the backplate and clamp the casing in place (Figure 45).

NOTE: Rotate the impeller manually to ensure it does not rub on the backplate or casing.

Disassembly of Modular Base-Mounted Pumps

Refer to “Disassembly of Pump With a Type 1 Seal” on page 32 and “Type 4 Double Seal” on page 37 for information on disassembling the pump seal items.

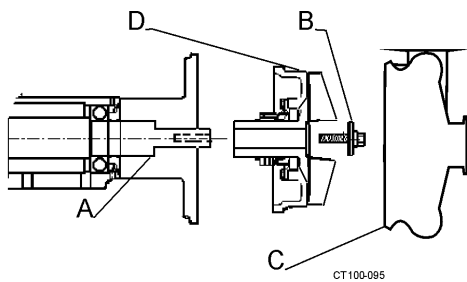

Figure 46 - Removing the Impeller Assembly

1. Shut off the product flow to the pump and relieve any product pressure.
2. Shut off and lock out power to the pump.
3. Disconnect the suction and discharge pipe fittings.
4. Remove the casing clamp and casing (Figure 46, item C). Slide the o-ring off of the backplate
5. Remove the impeller retainer bolt and shaft o-ring (Figure 46, item B).
6. Pull the impeller/backplate assembly off the bearing housing shaft (Figure 46, items D and A).

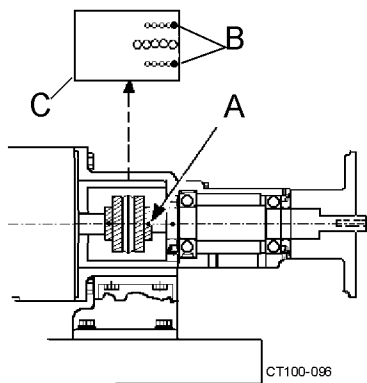

Figure 47 - Removing Coupling Covers

7. Remove the coupling cover cap screws (Figure 47, item B).
8. Loosen the set screws on the pump coupling (Figure 47, item A).
9. Remove the stand/housing assembly, then remove the end cap (Figure 51, item C on page 42).
10. Push the shaft and bearing assembly out of the housing from the impeller end. (Figure 48).
11. Remove the retaining ring and press the bearings off the shaft (Figure 48, items A and B).

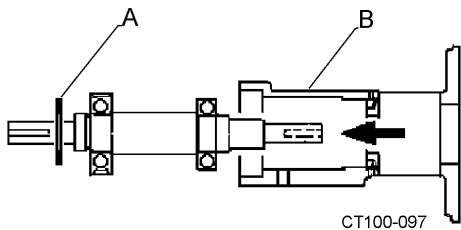

Figure 48 - Bearing Shaft Assembly Removal

Disassembling the Outer Seal Assemblies

1. Using an 1/8" hex wrench, loosen the set screws (Figure 49, item A).

NOTE: The set screws are located opposite the grease fittings in the adapter or end cap.

2. Remove the impeller end of the bearing housing (Figure 49, item B).

3. Remove the outer seal ring assemblies (the inner seal ring and o-rings). See Figure 49 and Figure 50.

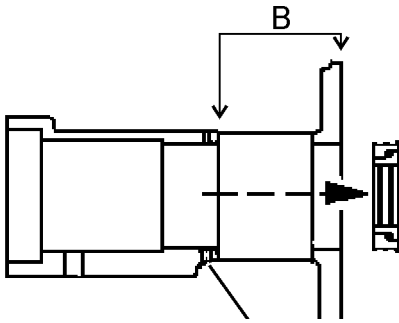
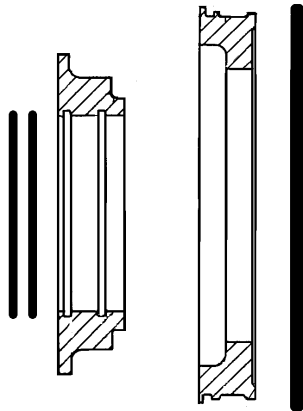

Figure 49 - Remove Set Screws

Assembling the Outer Seal Assemblies

Reverse the disassembly procedure (above) with the added step of installing new o-rings in the seal rings.

NOTE: Figure 49 shows the seal position at the motor end. Seals at the pump end face inward. Make sure to tighten the set screws when installing the outer seal assemblies (Figure 51).



Inner Seal

Outer Seal

Figure 50 - Seal Configuration

NOTE: Replace all rubber parts whenever a unit is dismantled for inspection or repair. Lubricate the rubber parts with an approved/sanitary lubricant prior to assembly.

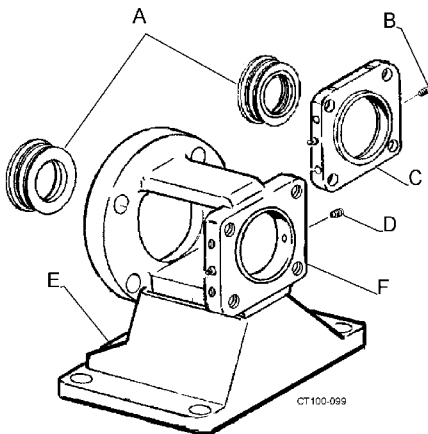

Figure 51 - Outer Seal Assemblies

A. Outer Seal Assembly	D. Set Screw
B. Set Screw	E. Adapter
C. End Cap	F. Stand

Pre-assembled (Cartridge) Seals

Pre-assembled (Cartridge) seals have all of the seal components mounted to a flange, and are pre-adjusted at the factory. Follow the seal manufacturer's (John Crane, A.W. Chesterton, etc.) recommendations regarding application, operation and maintenance.

NOTE: The cartridge seal comes with a set of removable lugs/spacers in place that are used to hold the assembly together until installation is final. Do not remove these lugs until installation is complete and you are instructed to do so in step 17 on page 46.

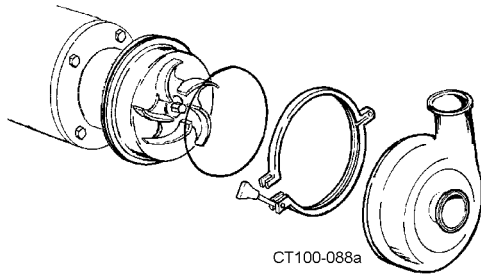

Figure 52 - Remove Casing Clamp, Casing and O-ring

Disassembly of Pre-assembled (Cartridge) Seals

1. Remove all flush connections and fittings.
2. Remove the casing clamp, casing, and o-ring from the housing flange (Figure 52).
3. Remove the impeller retainer bolt and o-ring; then loosen the seal set screws (Figure 53, item A).
4. Pull the impeller, backplate, and seal off the bearing shaft as a unit. Set the assembly face down (on the impeller).

NOTE: The clearance shims that position the impeller within the casing are at the end of the impeller hub (inside the seal.) Keep the shims together as a set for reassembly (Figure 54).

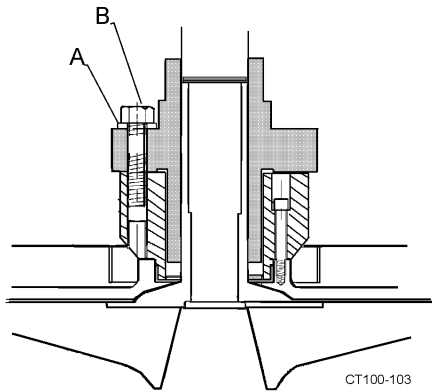

Figure 53 - Removal of Wet End

5. Remove the cap screws (Figure 54, item B) holding the cartridge seal to the seal adapter (Figure 54, items C and E).
6. Remove the seal unit from the backplate assembly.
7. Pull the seal from the seal adapter. (Figure 54, items C and E)
8. Remove the seal adapter by removing the socket head cap screws (Figure 54, item D) holding the adapter to the backplate.

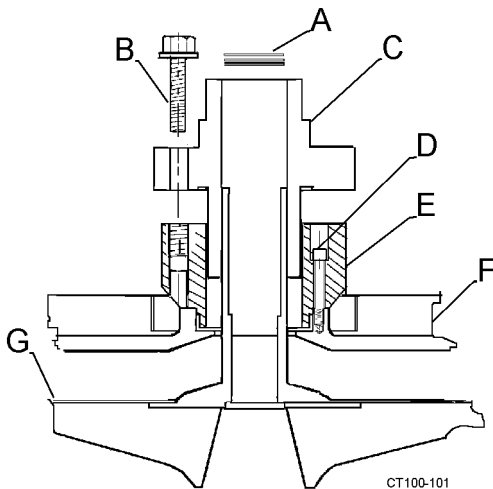

Figure 54 - Remove Seal Assembly.

A. Shims	E. Adapter
B. Cap Screw	F. Backplate
C. Cartridge Seal	G. Impeller
D. Socket Head Screw	

Assembly of a Pump With Pre-assembled (Cartridge) Seals

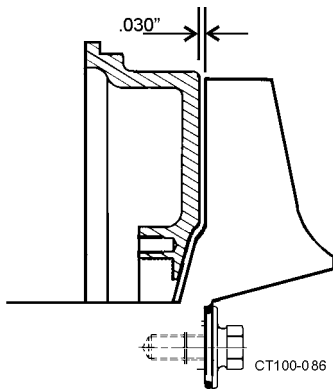

Figure 55 - Clearance Between Impeller and Backplate

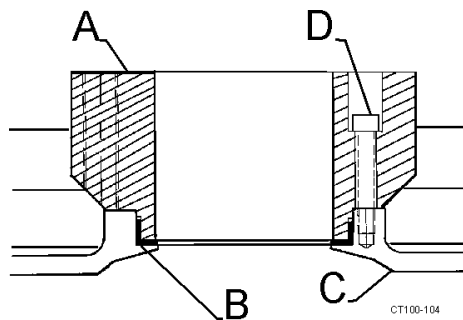

Figure 56 - Insert L-gasket, Fasten Adapter in Place

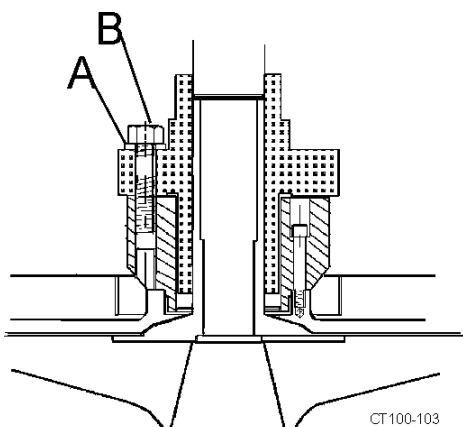

Figure 57 - Fastening Seal Unit in Place

1. Place the shims, backplate and impeller on the shaft assembly. Hand-tighten the impeller retainer bolt on the shaft.
2. Check the impeller/backplate clearance with the backplate held firmly in position against the motor adapter. Check the space between the back of the impeller and the backplate with a feeler gauge (0.030" nominal) while holding the backplate tight against the bearing housing flange. Any axial movement of the shaft should not be added to the 0.030" nominal clearance (Figure 55). If needed, change this clearance by adding or removing shims. Shims (Figure 54, item A) are added on the drive shaft behind the impeller shaft (Figure 54, item G).
3. Confirm the operating clearances by clamping the casing to the bearing housing flange and rotating the shaft/impeller manually to be sure the impeller does not touch the casing or backplate.
4. When the proper shim pack is confirmed, remove the casing, impeller and backplate, leaving the shim pack on the shaft.
5. Insert the L-gasket into the backplate (Figure 56, items B and C).
6. Insert the cartridge adapter (Figure 56, item A) into the backplate (Figure 56, item C) and tighten with four socket head cap screws (Figure 56, item D).
7. Install the cartridge seal unit and use the retaining bolts (Figure 57, item B) and flat washers (Figure 57, item A) to secure the unit to the cartridge adapter. Do not tighten the retaining bolts yet.



CAUTION: Be sure the removable lugs/spacers that position the rotating part of the seal in the housing are in place at this time.

8. Apply FDA-approved anti-seize compound to the shaft.

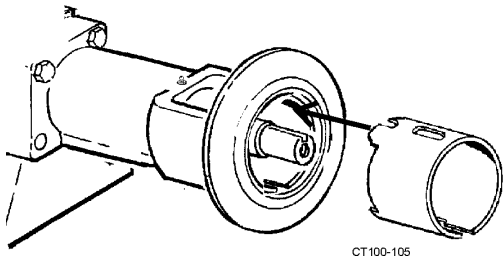

Figure 58 - Installing the Guard

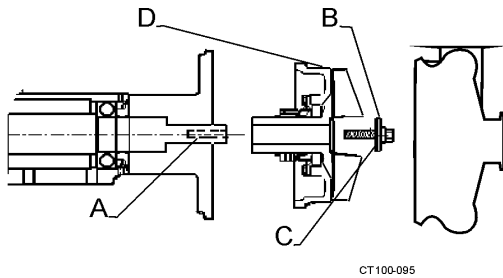

Figure 59 - Installing Impeller Assembly

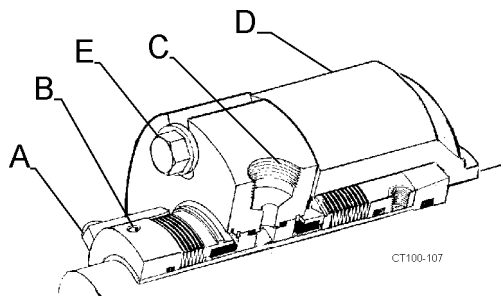

Figure 60 - Typical Cartridge Seal

A. Lugs/Spacers	D. Seal Adapter
B. Set Screw (2)	E. Cap Screws
C. Flush Pots	

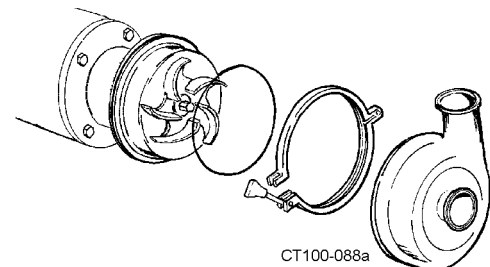

Figure 61 - Install O-ring, Casing, Clamp

9. (Pedestal Pump only)
Install and position the seal guard (Figure 58).
10. Slide the impeller, backplate and seal unit onto the shaft.

NOTE: Be sure the flushing ports in the cartridge seal are positioned with the inlet toward the bottom and the outlet toward the top (Figure 60, item C).

11. Install the impeller key (Figure 59, item A).
12. Install the o-ring on the impeller retainer bolt (Figure 59, item C).
13. Install the impeller retainer bolt and tighten it (Figure 59, item B).
14. Hold the backplate in place and tighten the cartridge seal into the cartridge adapter by tightening the cap screws (Figure 60, item E).

NOTE: The backplate and seal can be rotated to give access to the bolts through the holes in the guard.

15. Install the o-ring and casing; clamp in place (Figure 61).
16. Tighten the two set screws to the shaft (Figure 60, item B).
17. Remove the lugs/spacers (Figure 60, item A).

NOTE: Keep the lugs/spacers to reinstall on the seal cartridge if removal is ever required.

18. Connect the flushing fluid and flood seal.
19. Turn the shaft manually to be sure the shaft rotates without the impeller hitting or binding.

Pedestal Base-Mounted Pump Housing Lubrication

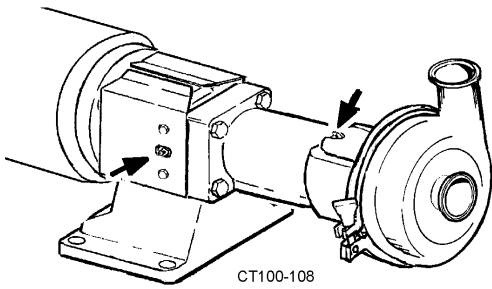

Figure 62 - Grease Fittings on the Pedestal Pump

Waukesha Series 200 Pedestal Pumps are lubricated with NLGI grade 2 Lithium Complex Grease. Use only NLGI grade 2 Lithium Complex thickened greases to replenish the bearing grease supply. The location of the grease fittings is indicated in Figure 62.

NOTE: Combining greases that will not mix with the products above can change the viscosity/consistency of the grease, resulting in bearing damage. If there is doubt, remove the bearings, clean, and re-pack them.

For compatible lubricants, contact Waukesha Cherry-Burrell Application Engineering at 1-800-252-5200 or 262-728-1900.

Lubrication Schedule

Size/RPM	Hours
Small Bore/1750 RPM	4400
Small Bore/3500 RPM	2000
Large Bore/1750 RPM	2000
Large Bore/3500 RPM	1000

NOTE: If operating temperatures are over 158°F (70°C), reduce hours by half for every 27°F (15°C) over the operating temperature.

Pump Alignment

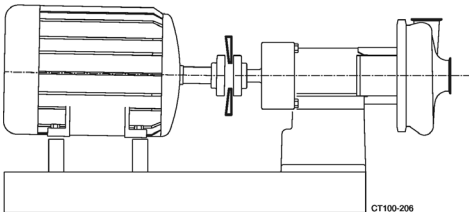
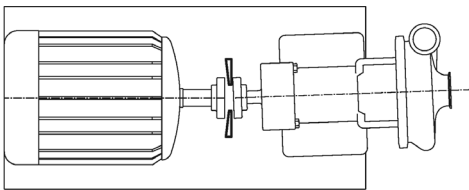

Figure 63 - Checking Angular Alignment

A flexible coupling is used to compensate for end play and small differences in alignment. The pump and drive shaft should be aligned as closely as possible.

Checking Angular Alignment

Using feeler gauges or taper gauges, adjust to get equal dimension at all points. At the same time, set space between the coupling halves to the manufacturer's recommended distance.

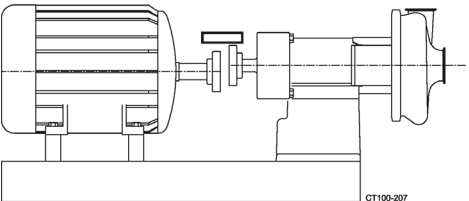
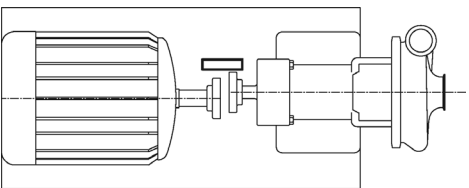

Figure 64 - Checking Parallel Alignment

Checking Parallel Alignment

Using straight edges and shims, move the drive and shim height as needed.

Servicing the Electric Motor



CAUTION: *Do not over-grease. Excessive lubrication may damage the unit.*



WARNING: *Disconnect all power sources to the unit and discharge all parts which may retain an electrical charge before attempting any maintenance or repair. Screens and covers must be maintained in place when the unit is in operation.*

See the motor manufacturer's instructions for specific service information.

General Service Information

Inspect units at regular intervals.

Keep units clean and ventilation openings clear of dust, dirt or other debris.

Lubricate the units per the manufacturer's instructions and the instruction plate on the unit.

Motor Lubrication Instructions

Some small motors have sealed-for-life bearings which require no lubrication.

Greasable bearings are shipped with a high-quality, wide-temperature-range grease in the bearings.

Some motors can be greased. Refer to the motor manufacturer's instructions for more information regarding lubrication procedures and additional service procedures.

Standard Seal Dimensions

The following seal assemblies are available with the 200 Series Pumps. These sketches provide the installed length dimension for each seal to facilitate assembly.

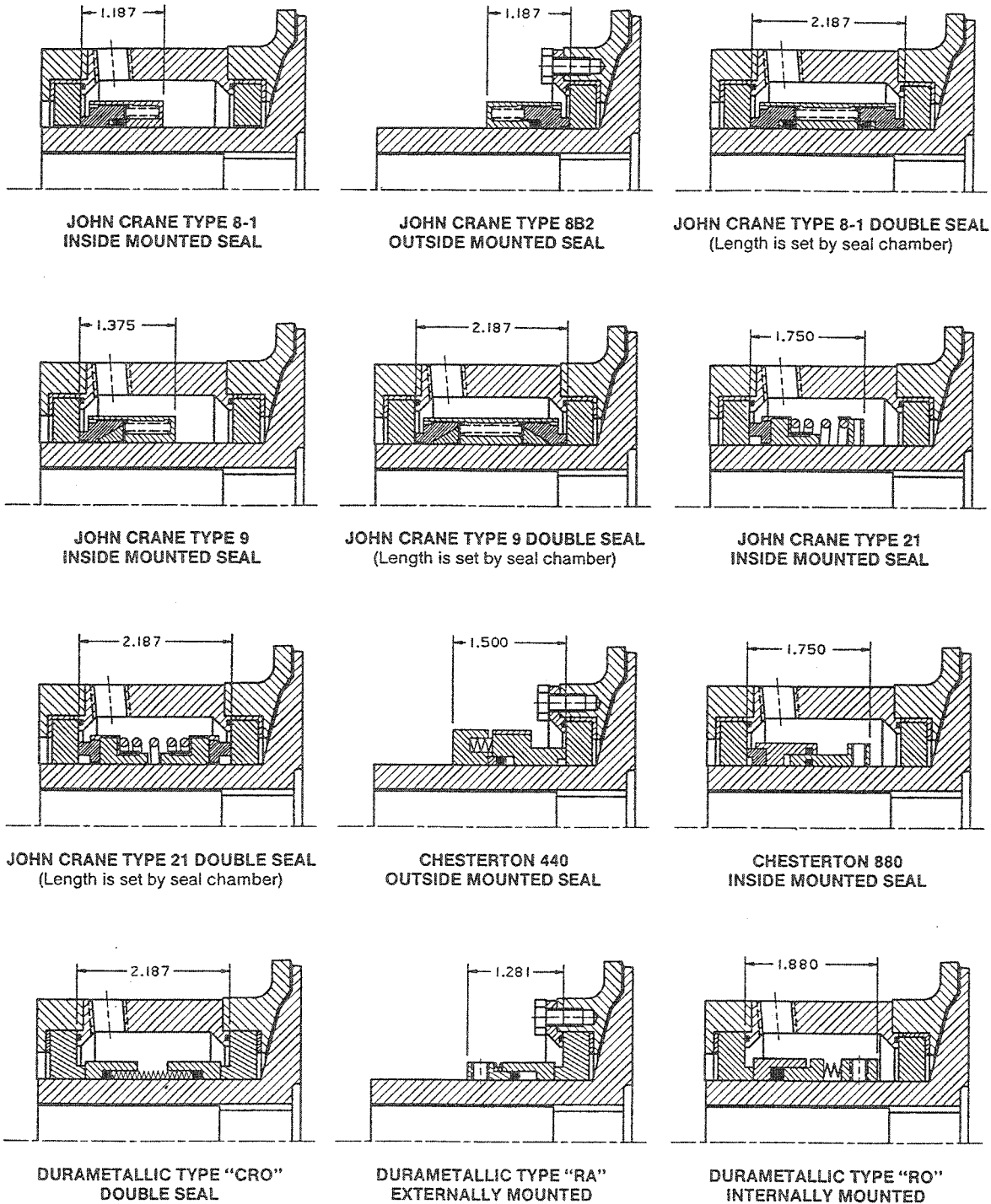

Figure 65 - Installed Seal Length (for aid of assembly)

Cartridge Seal Dimensions

The following pictorial list of cartridge seals is provided to assist in identifying some of the seals provided with the Model 200 centrifugal pumps. Use of these cartridges requires a cartridge seal adapter.

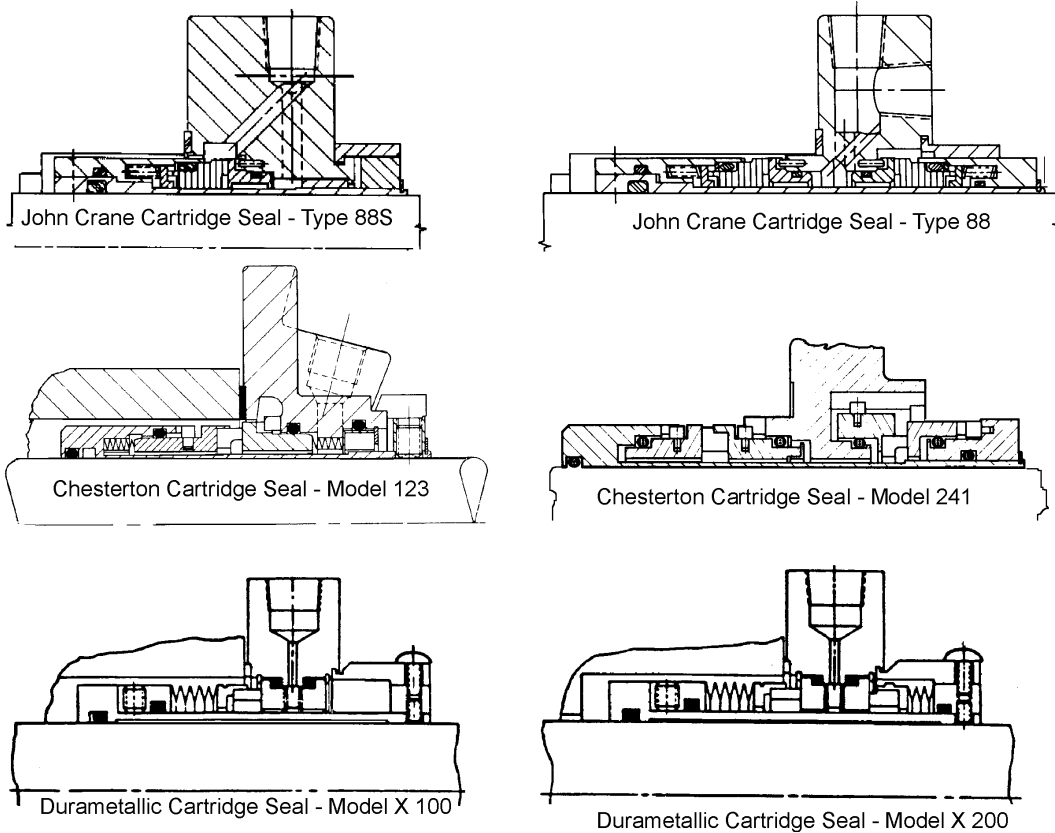
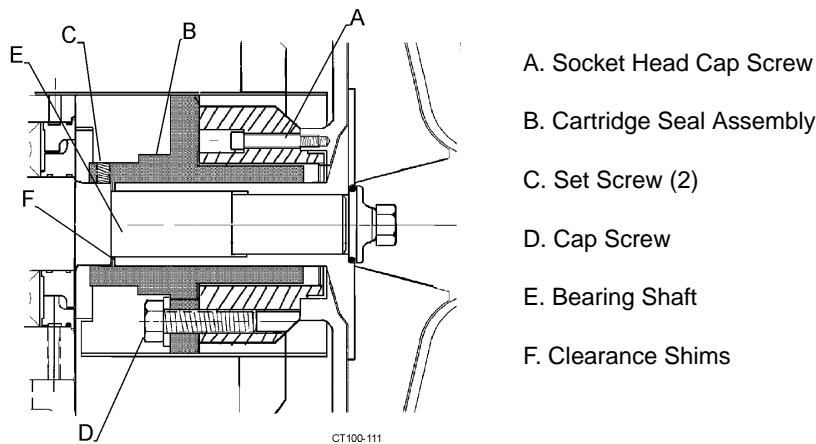

Figure 66 - Installed Cartridge Seal Length (for aid of assembly)



- A. Socket Head Cap Screw
- B. Cartridge Seal Assembly
- C. Set Screw (2)
- D. Cap Screw
- E. Bearing Shaft
- F. Clearance Shims

Figure 67 - Typical Cartridge Seal Installation

Parts Lists

Type 1 Seal Kits

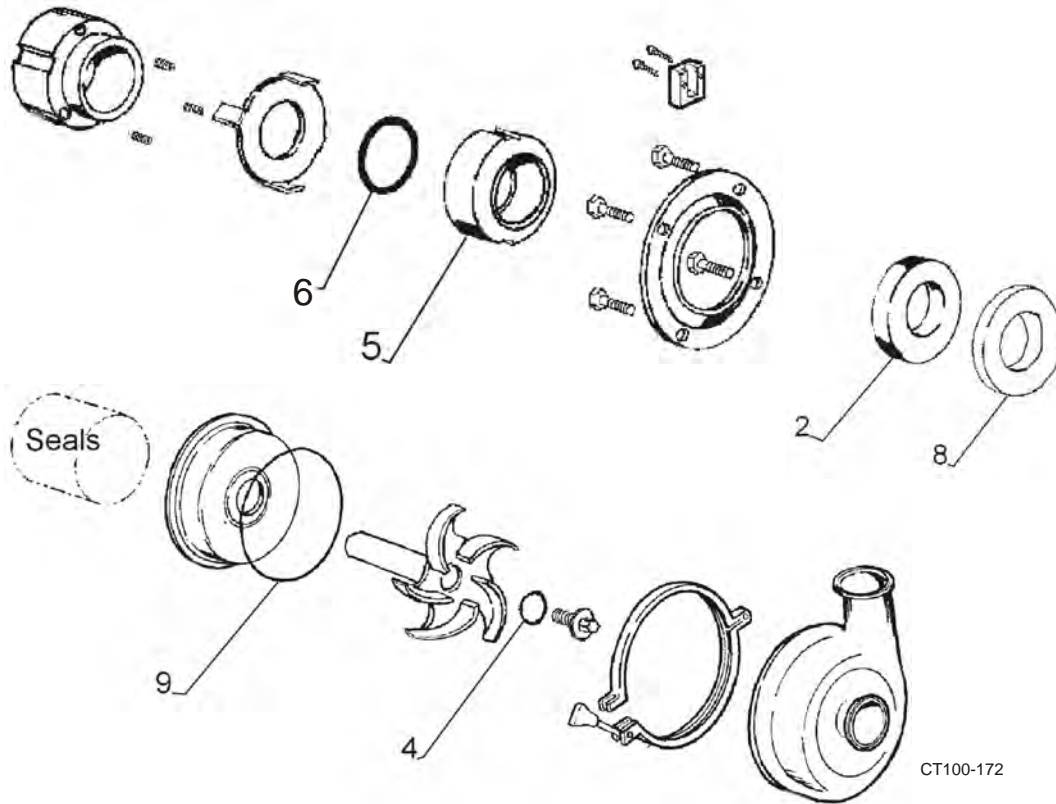

Basic Seal Kit

KIT CONTAINS		QTY. REQ. PER PUMP	QTY. IN TYPE 1 BASIC	2045	2065LV 2065 2065HV	2075	2085LV 2085	2105
ITEM NO.	DESCRIPTION							
4	Impeller Retainer O-Ring, FKM	1	1	V70214	V70220	V70220	V70220	V70220
5	Rotary Seal, Carbon	1	1	9-225A	9-225A	9-225A	9-225A	9-225A
6	Seal O-Ring, FKM	1	1	V70224	V70224	V70224	V70224	V70224
9	Casing O-Ring, FKM	1	1	V70252	V70439	V70446	V70446	V70450
KIT PART NUMBER				309-241	309-242	309-243	309-243	309-244

FL5030-CH13

Complete Seal Kit

KIT CONTAINS		QTY. REQ. PER PUMP	QTY. IN TYPE 1 BASIC	2045	2065LV 2065 2065HV	2075	2085LV 2085	2105
ITEM NO.	DESCRIPTION							
2	Stationary Seal, Purebide	1	1	23-17	23-17	23-17	23-17	23-17
4	Impeller Retainer O-Ring, FKM	1	1	V70214	V70220	V70220	V70220	V70220
5	Rotary Seal, Carbon	1	1	9-225A	9-225A	9-225A	9-225A	9-225A
6	Seal O-Ring, FKM	1	1	V70224	V70224	V70224	V70224	V70224
8	L-Gasket, FKM	1	1	9-37	9-37	9-37	9-37	9-37
9	Casing O-Ring, FKM	1	1	V70252	V70439	V70446	V70446	V70450
KIT PART NUMBER				309-245	309-246	309-247	309-247	309-248

FL5030-CH14

Type 4 Seal Kits

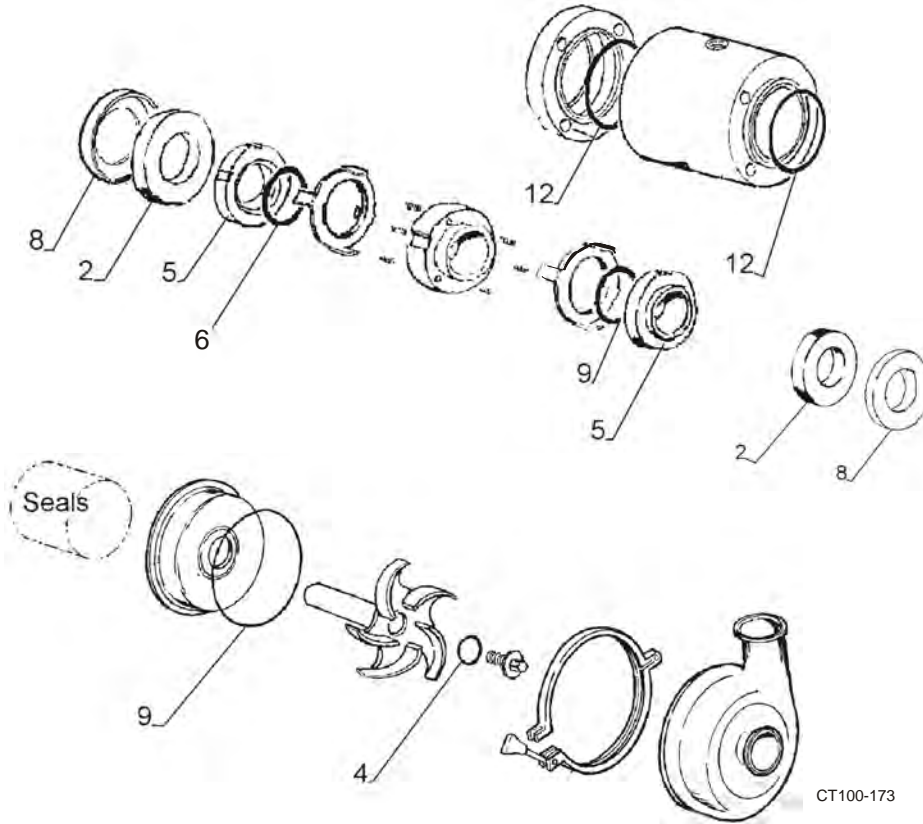

Basic Seal Kit

KIT CONTAINS		QTY.	QTY. IN	2045	2065LV	2075	2085LV	2105
ITEM NO.	DESCRIPTION	REQ. PER PUMP	TYPE 1 BASIC	2045	2065 2065HV	2075	2085 2085	2105
4	Impeller Retainer O-Ring, FKM	1	1	V70214	V70220	V70220	V70220	V70220
5	Rotary Seal, Carbon	2	2	9-225A	9-225A	9-225A	9-225A	9-225A
6	Seal O-Ring, FKM	2	2	V70224	V70224	V70224	V70224	V70224
9	Casing O-Ring, FKM	1	1	V70252	V70439	V70446	V70446	V70450
12	Seal Housing O-Ring, FKM	2	2	V70039	V70039	V70039	V70039	V70039
KIT PART NUMBER				309-249	309-250	309-251	309-251	309-252

PL5030-CH15

Complete Seal Kit

KIT CONTAINS		QTY.	QTY. IN	2045	2065LV	2075	2085LV	2105
ITEM NO.	DESCRIPTION	REQ. PER PUMP	TYPE 1 BASIC	2045	2065 2065HV	2075	2085 2085	2105
2	Stationary Seal, Purebide	2	2	23-17	23-17	23-17	23-17	23-17
4	Impeller Retainer O-Ring, FKM	1	1	V70214	V70220	V70220	V70220	V70220
5	Rotary Seal, Carbon	2	2	9-225A	9-225A	9-225A	9-225A	9-225A
6	Seal O-Ring, FKM	2	2	V70224	V70224	V70224	V70224	V70224
8	L-Gasket, FKM	2	2	9-37	9-37	9-37	9-37	9-37
9	Casing O-Ring, FKM	1	1	V70252	V70439	V70446	V70446	V70450
12	Seal Housing O-Ring, FKM	2	2	V70039	V70039	V70039	V70039	V70039
KIT PART NUMBER				309-253	309-254	309-255	309-255	309-256

PL5030-CH16

Type 1 Seal Components and Common Parts

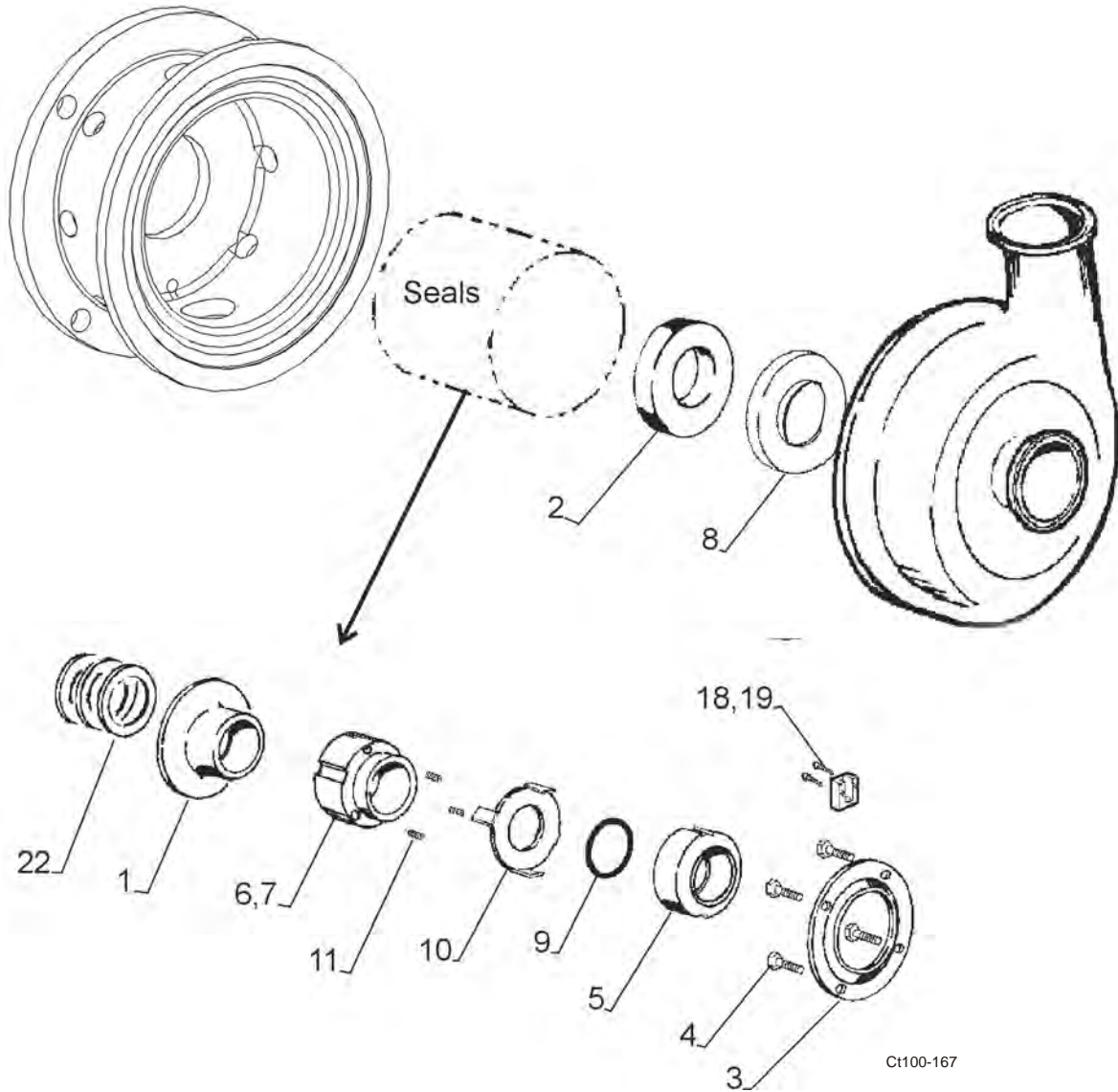

Type 1 Seal Components and Common Parts

ITEM NO.	DESCRIPTION	QTY. PER PUMP	PART NO.	NOTES
1	Deflector	1	69-1	
* 2	Stationary Seal, Purebide	1	23-17	
* 2	Stationary Seal, Silicon Carbide	1	23-17A	
* 2	Stationary Seal, Tungsten Carbide	1	23-17F	
3	Stationary Seal Retainer	1	23-78	
4	1/4-20 x 1/2 Bolt	4	30-62	
* 5	Rotary Seal, Carbon	1	9-225A	
* 5	Rotary Seal, Purebide	1	9-225B	
* 5	Rotary Seal, Silicon Carbide	1	9-225C	
* 5	Rotary Seal, Tungsten Carbide	1	9-225F	
6	1/4-20 x 3/8 Set Screw	2	30-178	
7	Spring Retainer	1	23-77	
* 8	L-Gasket, FKM	1	9-37	
* 8	L-Gasket, EPDM	1	9-37E	
* 8	L-Gasket, Silicone	1	9-37R	
* 8	L-Gasket, FFKM	1	9-37K	
* 8	L-Gasket, substitute, Teflon	1	20-278	1
* 8	Gasket Seal, Gore-Tex (used with 20-278)	1	T80041	1
* 9	Seal O-Ring, FKM	1	V70224	
* 9	Seal O-Ring, EPDM	1	E70224	
* 9	Seal O-Ring, Silicone	1	S75224	
* 9	Seal O-Ring, FFKM	1	K75224	
10	Washer, tabbed	1	43-87	
11	Spring	3	24-65	
18	Block, Water (For type 1 cascade)	1	134-2	
19	8-32 x 1/4 Screw (For type 1 cascade)	1	30-176	
20	1/4" Plastic Hose (For type 1 cascade)	1	74-1	
21	1/4" Hose Fitting (For type 1 cascade)	1	78-18	
22	Shim, 1" x .005" 143-215JM	as req'd	35-1	
	Shim, 1" x .010" 143-215JM	as req'd	35-2	
	Shim, 1" x .020" 143-215JM	as req'd	35-3	
	Shim, 1-3/8" x .005" 254-326JM	as req'd	35-4	
	Shim, 1-3/8" x .010" 254-326JM	as req'd	35-5	
	Shim, 1-3/8" x .020" 254-326JM	as req'd	35-6	

PL5030-CH11

NOTES:

* **Recommended Spare Parts**

1. T80041 must be used in conjunction with 20-278 if 20-278 is selected.

Type 4 Seal Components and Common Parts

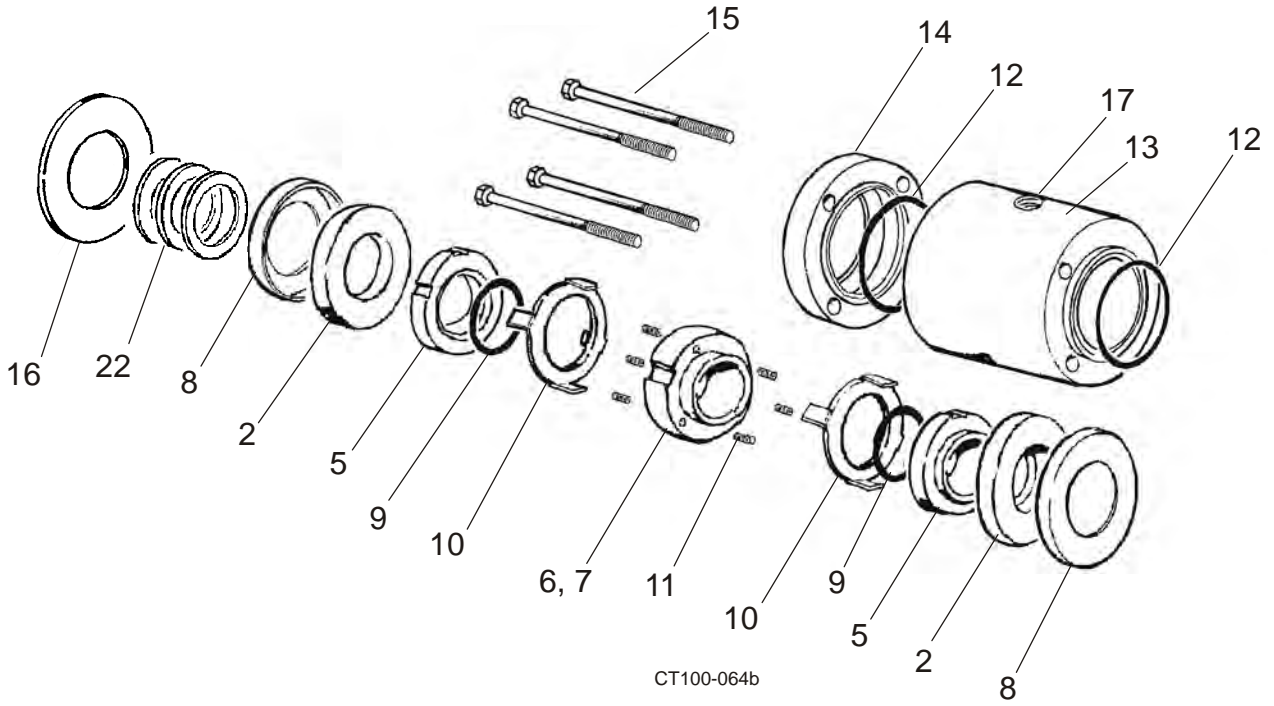

Type 4 Seal Components and Common Parts

ITEM NO.	DESCRIPTION	QTY. PER PUMP	PART NO.	NOTES
* 2	Stationary Seal, Purebide	2	23-17	
* 2	Stationary Seal, Silicon Carbide	2	23-17A	
* 2	Stationary Seal, Tungsten Carbide	2	23-17F	
* 5	Rotary Seal, Carbon	2	9-225A	
* 5	Rotary Seal, Purebide	2	9-225B	
* 5	Rotary Seal, Silicon Carbide	2	9-225C	
* 5	Rotary Seal, Tungsten Carbide	2	9-225F	
6	1/4-20 x 3/8 Set Screw	2	30-178	
7	Spring Retainer	1	23-77	
* 8	L-Gasket, FKM	2	9-37	
* 8	L-Gasket, EPDM	2	9-37E	
* 8	L-Gasket, Silicone	2	9-37R	
* 8	L-Gasket, FFKM	2	9-37K	
* 8	L-Gasket, substitute, Teflon	2	20-278	1
* 8	Gasket Seal, Gore-Tex (used with 20-278)	2	T80041	1
* 9	Seal O-Ring, FKM	2	V70224	
* 9	Seal O-Ring, EPDM	2	E70224	
* 9	Seal O-Ring, Silicone	2	S75224	
* 9	Seal O-Ring, FFKM	2	K75224	
10	Washer, tabbed	2	43-87	
11	Spring	6	24-65	
* 12	O-Ring, Housing, FKM	2	V70039	
13	Housing, Seal	1	23-80	
14	Retainer, Seal	1	23-79	
15	1/4-20 x 3 Cap Screw	4	30-175	
16	Slinger, 143-215JM	1	69-4	
16	Deflector, 254-326JM	1	69-1	
17	1/4" NPT Plug	2	78-155	
22	Shim, 1" x .005" 143-215JM	as req'd	35-1	
22	Shim, 1" x .010" 143-215JM	as req'd	35-2	
22	Shim, 1" x .020" 143-215JM	as req'd	35-3	
22	Shim, 1-3/8" x .005" 254-326JM	as req'd	35-4	
22	Shim, 1-3/8" x .010" 254-326JM	as req'd	35-5	
22	Shim, 1-3/8" x .020" 254-326JM	as req'd	35-6	

PL5030-CH12

NOTES:

* Recommended Spare Parts

1. T80041 must be used in conjunction with 20-278 if 20-278 is selected.

2045 Pump Parts

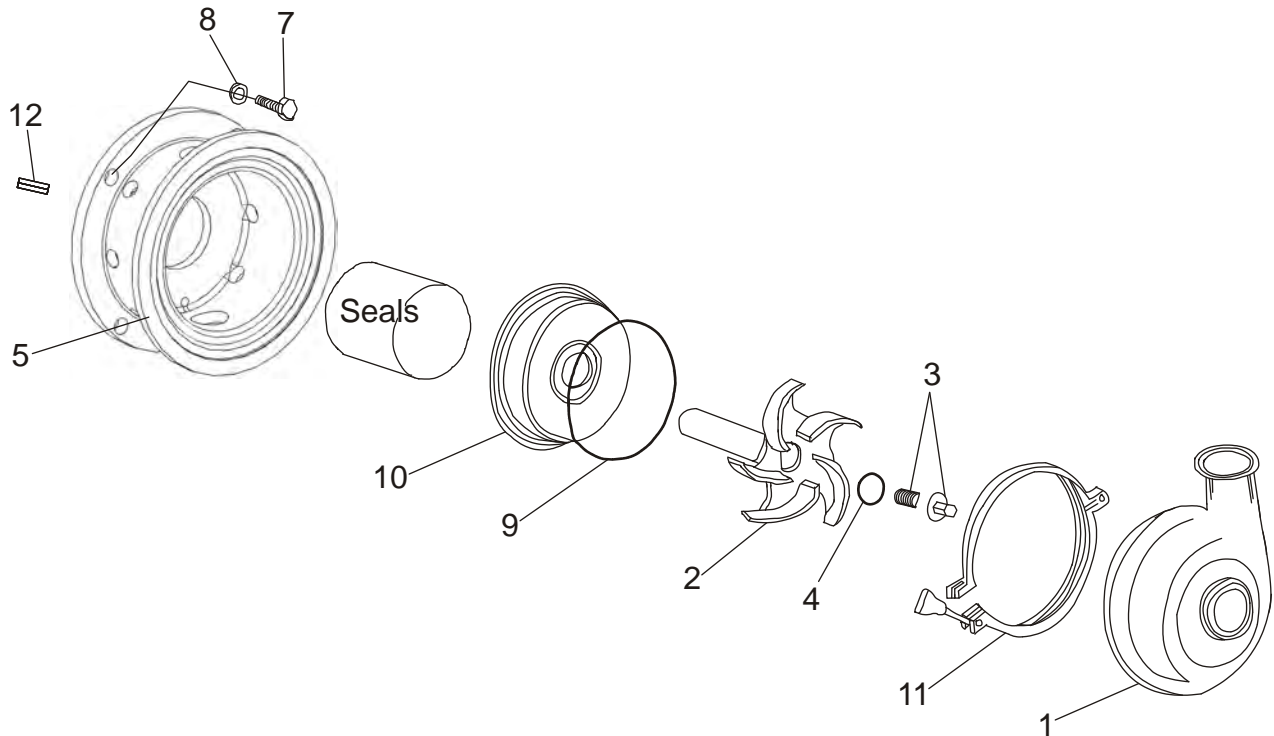

CT100-113a

2045 Casing Parts

FITTING TYPE	SANITARY		NOTES
	1-1/2 x 1-1/2	2 x 1-1/2	
S-Line (MP)	CENTPT00549	CENTPT00550	
Bevel Seat	CENTPT00551	CENTPT00552	
I-Line; Female	CENTPT00553	CENTPT00554	
I-Line; Male	CENTPT00555	CENTPT00556	
Q-Line	CENTPT00557	CENTPT00558	
Weld	CENTPT00559	CENTPT00560	
NPT; Male	CENTPT00561	CENTPT00562	1
NPT; Female	CENTPT00563	CENTPT00564	1
150 LB. Flange	CENTPT00565	CENTPT00566	1

PL5030-CH2

NOTES:

- 1. These casings **do not** meet the requirements of 3A Sanitary Standards.

2045 Pump Parts

ITEM NO.	DESCRIPTION	QTY. PER PUMP	PART NO.	NOTES
1	Casing (see 2045 Casing Parts List)	1		
2	Impeller, Full 4.5" Diameter	1	5-80X	1
3	Impeller Retainer	1	129-773X	
* * * * *	Impeller O-Ring, FKM	1	V70214	
	Impeller O-Ring, EPDM	1	E70214	
4	Impeller O-Ring, Silicone	1	S75214	
	Impeller O-Ring, FFKM	1	K75214	
	Impeller O-Ring, PTFE ENCAP.	1	T80214	
5	Adapter, 143JM - 184JM Frame, SS	1	122059+	2
7	3/8 - 16 x 3/4" Hex Screw	4	30-50	
8	3/8" Lockwasher	4	43-28	
* * * * *	Casing O-Ring, FKM	1	V70252	
	Casing O-Ring, EPDM	1	E70252	
9	Casing O-Ring, Silicone	1	S75252	
	Casing O-Ring, FFKM	1	K75252	
	Casing O-Ring, PTFE ENCAP.	1	T80252	
10	Backplate	1	1-59X	
11	Casing Clamp	1	119-71	
12	Key - 3/16"	1	65-3	

PL5030-CH1

NOTES:

- * **Recommended Spare Parts - available as kits for standard seals-see seal kit pages.**
- 1. Trimmed impellers use the same part number and price; specify the diameter required in 1/8" increments on order.
- 2. Previously supplied as 2 pieces, an adapter and a seal guard; now a single piece.

2065LV - 2065 - 2065HV Pump Parts

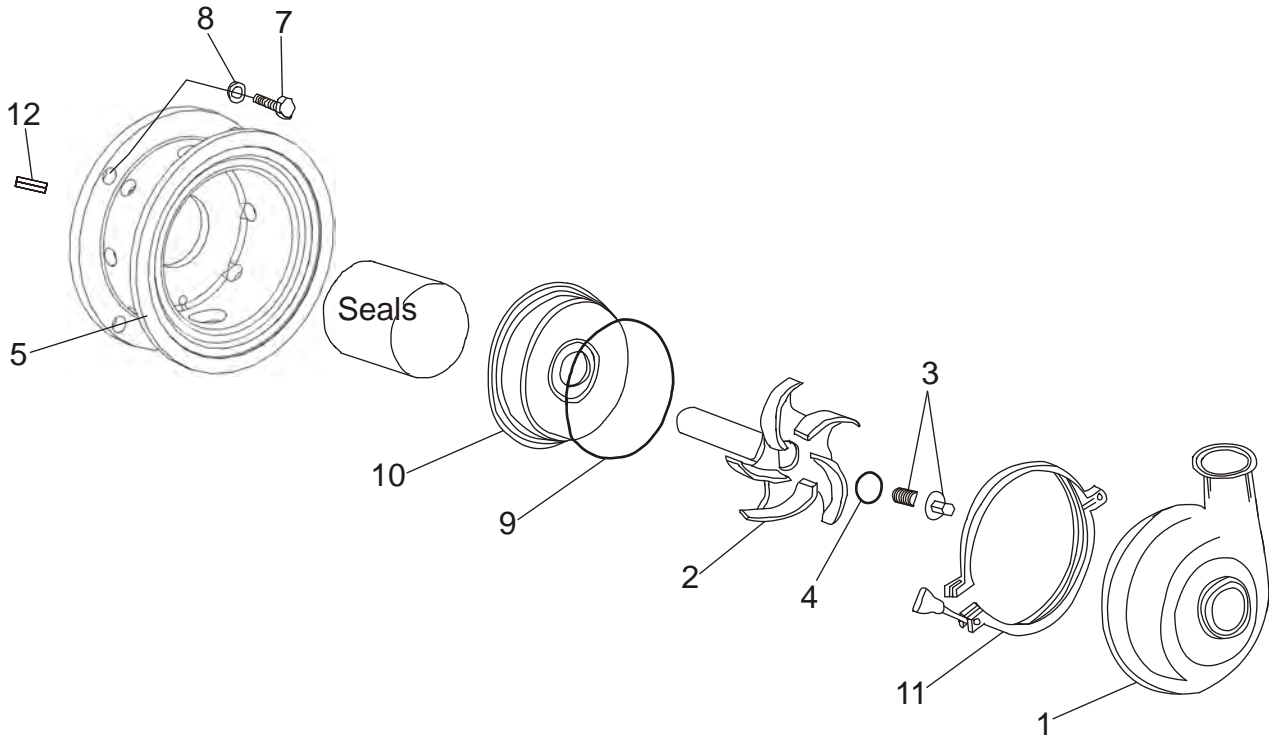

CT100-113a

2065LV - 2065 - 2065HV Casing Parts

FITTING TYPE	2065LV SANITARY			2065 SANITARY	2065HV SANITARY	NOTES
	1-1/2 x 1-1/2	2 x 1-1/2	2-1/2 x 1-1/2	2-1/2 X 2	3 X 2	
S-Line (MP)	CENTPT00569	CENTPT00455	CENTPT00413	CENTPT00417	CENTPT00570	
Bevel Seat	CENTPT00571	CENTPT00572	CENTPT00573	CENTPT00574	CENTPT00575	
I-Line; Female	CENTPT00576	CENTPT00577	CENTPT00578	CENTPT00579	CENTPT00580	
I-Line; Male	CENTPT00581	CENTPT00582	CENTPT00583	CENTPT00584	CENTPT00585	
Q-Line	CENTPT00586	CENTPT00587	CENTPT00588	CENTPT00589	CENTPT00590	
Weld	CENTPT00591	CENTPT00592	CENTPT00593	CENTPT00594	CENTPT00595	
NPT; Male	CENTPT00596	CENTPT00597	CENTPT00598	CENTPT00599	CENTPT00600	1
NPT; Female	CENTPT00601	CENTPT00602	CENTPT00603	CENTPT00604	CENTPT00605	1
150 LB. Flange	CENTPT00606	CENTPT00607	CENTPT00608	CENTPT00609	CENTPT00280	1

PL5030-CH4

NOTES:

1. These casings **do not** meet the requirements of 3A Sanitary Standards.

2065LV - 2065 - 2065HV Pump Parts

ITEM NO.	DESCRIPTION	QTY. PER PUMP	PART NO.	NOTES
1	Casing (see 2065LV-2065-2065HV Casing Parts List)	1		
2	2065LV Impeller, 6.5" Dia., 143-215JM, SM Bore	1	109256+	1
	2065LV Impeller, 6.5" Dia., 254-326JM, LG Bore	1	109258+	1
	2065 Impeller, 6.5" Dia., 143-215JM, SM Bore	1	109260+	1
	2065 Impeller, 6.5" Dia., 254-326JM, LG Bore	1	109262+	1
	2065HV Impeller, 6.5" Dia., 143-215JM, SM Bore	1	109264+	1
	2065HV Impeller, 6.5" Dia., 254-326JM, LG Bore	1	109266+	1
3	Impeller Retainer, 143-215JM SM Bore	1	129-771X	
	Impeller Retainer, 254-326JM LG Bore	1	129-772X	
* * * * *	Impeller O-Ring, FKM	1	V70220	
	Impeller O-Ring, EPDM	1	E70220	
	Impeller O-Ring, Silicone	1	S75220	
	Impeller O-Ring, FFKM	1	K75220	
	Impeller O-Ring, PTFE ENCAPSULATED	1	T80220	
5	Adapter, 143-184JM Frame, SS	1	122045+	2
	Adapter, 213-215JM Frame, SS	1	122035+	2
	Adapter, 254-256JM Frame, SS	1	121888+	2
	Adapter, 284-326JM Frame, SS	1	122069+	2
7	3/8-16 x 1" Hex Screw, 143-184JM Frame	4	30-30	
	1/2-13 x 1-1/4" Hex Screw, 213-256JM Frame	4	30-36X	
	5/8-11 x 1-1/2" Hex Screw, 284-326JM Frame	4	30-105	
8	3/8" Lockwasher	4	43-28	
	1/2" Lockwasher	4	43-16	
	5/8" Lockwasher	4	43-33	
* * * * *	Casing O-Ring, FKM	1	V70439	
	Casing O-Ring, EPDM	1	E70439	
	Casing O-Ring, Silicone	1	S75439	
	Casing O-Ring, FFKM	1	K75439	
	Casing O-Ring, PTFE ENCAPSULATED	1	T80439	
10	Backplate	1	1-60X	
11	Casing Clamp	1	119-70	
12	Key-3/16", 143-215JM, SM Bore	1	65-3	
	Key-1/4", 254-326JM, LG Bore	1	65-4	

PL5030-CH3

NOTES:

- * **Recommended Spare Parts - available as kits for standard seals-see seal kit pages.**
- 1. Trimmed impellers use the same part number and price; specify the diameter required in 1/8"
- 2. Previously supplied as 2 pieces, an adapter and a seal guard; now a single piece.

2075 Pump Parts

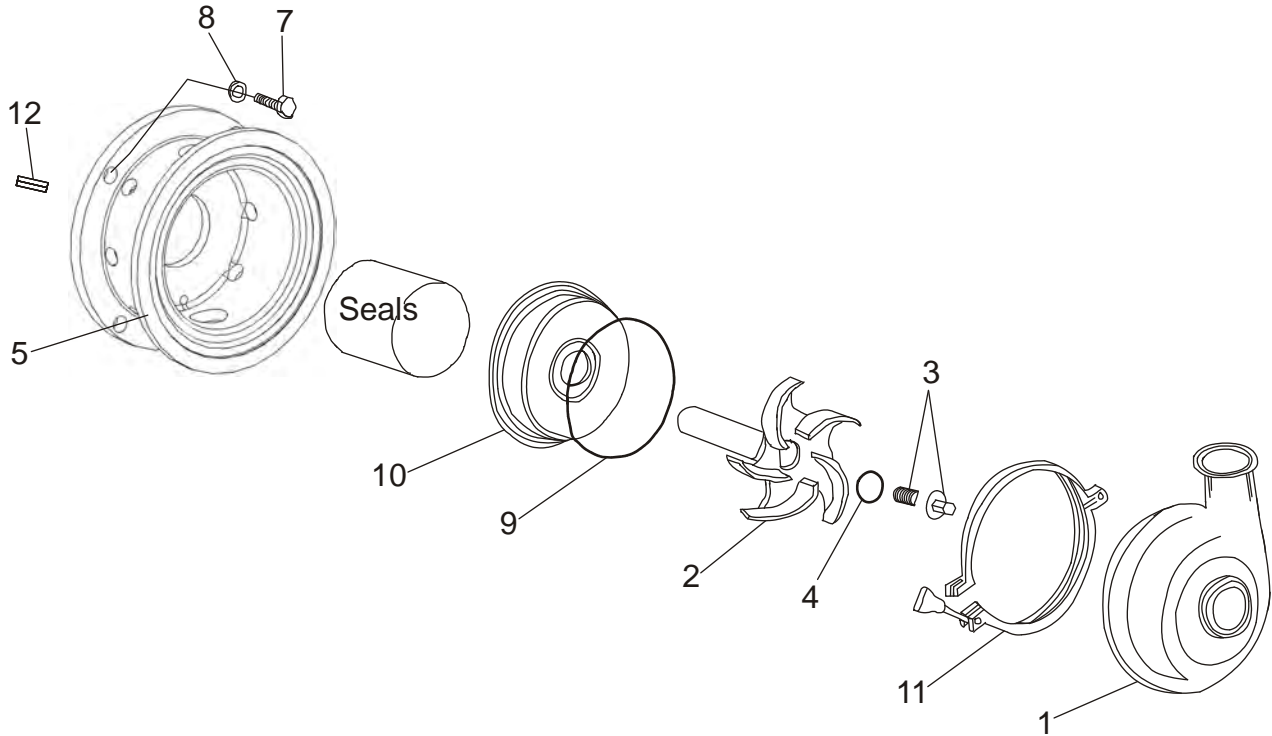

CT100-113a

2075 Casing Parts

FITTING TYPE	SANITARY	NOTES
	3 x 1-1/2	
S-Line	CENTPT00669	
Bevel Seat	CENTPT00670	
I-Line; Female	CENTPT00671	
I-Line; Male	CENTPT00672	
Q-Line	CENTPT00673	
Weld	CENTPT00674	
NPT; Male	CENTPT00675	1
NPT; Female	CENTPT00676	1
150 LB. Flange	CENTPT00677	1

PL5030-CH6

NOTES:

1. These casings **do not** meet the requirements of 3A Sanitary Standards.

2075 Pump Parts

ITEM NO.	DESCRIPTION	QTY. PER PUMP	PART NO.	NOTES
1	Casing (see 2075 Casing Parts List)	1		
2	2075 Impeller, 8.7" Dia., 143-215JM, SM Bore	1	109723+	1
	2075 Impeller, 8.7" Dia., 254-326JM, LG Bore	1	109741+	1
3	Impeller Retainer, 143-215JM, SM, Bore	1	129-771X	
	Impeller Retainer, 254-326JM, LG, Bore	1	129-772X	
* * * * *	Impeller O-Ring, FKM	1	V70220	
	Impeller O-Ring, EPDM	1	E70220	
	Impeller O-Ring, Silicone	1	S75220	
	Impeller O-Ring, FFKM	1	K75220	
	Impeller O-Ring, PTFE ENCAPSULATED	1	T80220	
5	Adapter, 143-184JM Frame, SS	1	122053+	2
	Adapter, 213-215JM Frame, SS	1	122055+	2
	Adapter, 254-256JM Frame, SS	1	122096+	2
	Adapter, 284-326JM Frame, SS	1	122057+	2
7	3/8-16 x 1" Hex Screw, 143-184JM Frame	4	30-30	
	1/2-13 x 1-1/4 Hex Screw, 213-256JM Frame	4	30-36X	
	5/8-11 x 1-1/2" Hex Screw, 284-326JM Frame	4	30-105	
8	3/8" Lockwasher	4	43-28	
	1/2" Lockwasher	4	43-16	
	5/8" Lockwasher	4	43-33	
* * * * *	Casing O-Ring, FKM	1	V70446	
	Casing O-Ring, EPDM	1	E70446	
	Casing O-Ring, Silicone	1	S75446	
	Casing O-Ring, FFKM	1	K75446	
	Casing O-Ring, PTFE ENCAPSULATED	1	T80446	
10	Backplate	1	1-61X	
11	Casing Clamp	1	119-69	
12	Key-3/16", 143-215JM, SM Bore	1	65-3	
	Key-1/4", 254-326JM, LG Bore	1	65-4	

PL5030-CH5

NOTES:

- * **Recommended Spare Parts - available as kits for standard seals-see seal kit pages.**
- 1. Trimmed impellers use the same part number and price; specify the diameter required in 1/8"
- 2. Previously supplied as 2 pieces, an adapter and a seal guard; now a single piece.

2085LV - 2085 Pump Parts

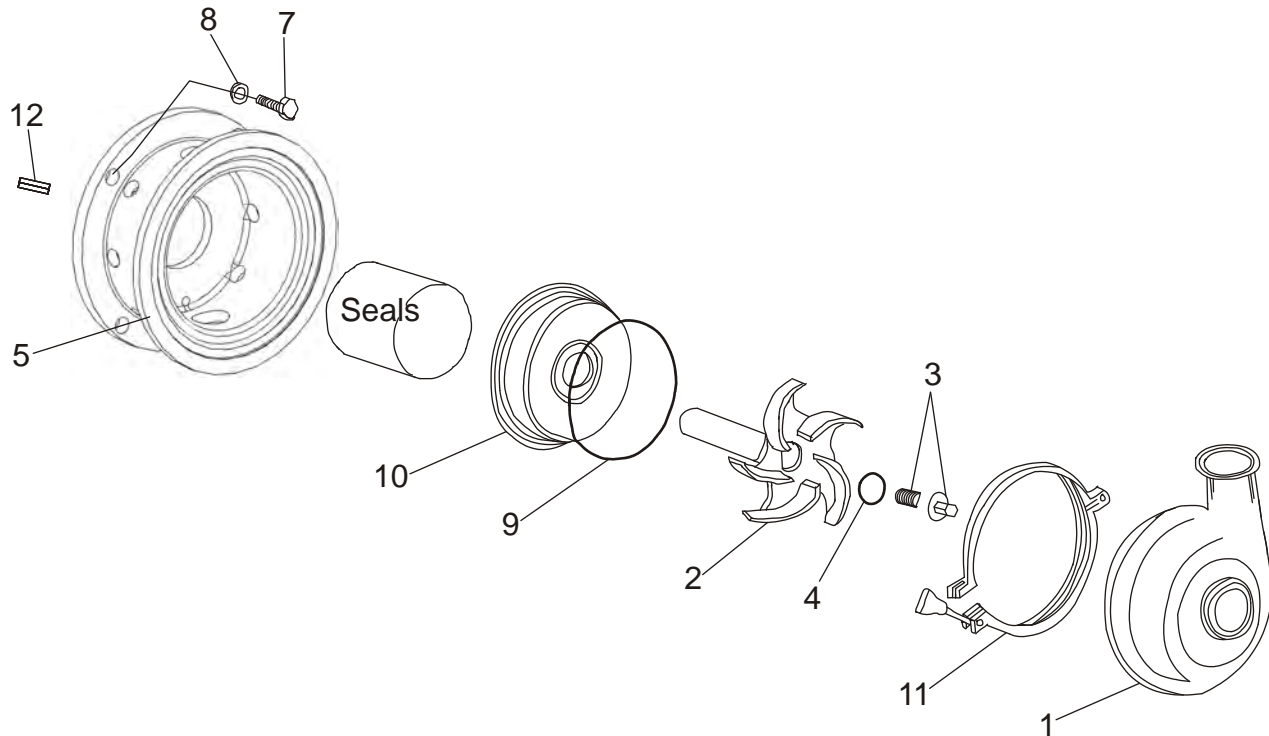

CT100-113a

2085LV - 2085 Casing Parts

FITTING TYPE	2085LV SANITARY	2085 SANITARY		NOTES
	2 X 1-1/2	3 x 2-1/2	4 x 2-1/2	
S-Line	CENTPT00613	CENTPT00462	CENTPT00477	
Bevel Seat	CENTPT00614	CENTPT00615	CENTPT00616	
I-Line; Female	CENTPT00617	CENTPT00618	CENTPT00619	
I-Line; Male	CENTPT00620	CENTPT00621	CENTPT00622	
Q-Line	CENTPT00623	CENTPT00624	CENTPT00625	
Weld	CENTPT00626	CENTPT00627	CENTPT00628	
NPT; Male	CENTPT00629	CENTPT00630	CENTPT00631	1
NPT; Female	CENTPT00632	CENTPT00633	CENTPT00634	1
150 LB. Flange	CENTPT00635	CENTPT00636	CENTPT00637	1

PL5030-CH8

NOTES:

1. These casings **do not** meet the requirements of 3A Sanitary Standards.

2085LV - 2085 Pump Parts

ITEM NO.	DESCRIPTION	QTY. PER PUMP	PART NO.	NOTES
1	Casing (see 2085LV-2085 Casing Parts List)	1		
2	2085LV Impeller, 8.7" Dia., 143-215JM, SM Bore	1	109723+	1
	2085LV Impeller, 8.7" Dia., 254-326JM, LG Bore	1	109741+	1
	2085 Impeller, 8.7" Dia., 143-215JM, SM Bore	1	109248+	1
	2085 Impeller, 8.7" Dia., 254-326JM, LG Bore	1	109249+	1
3	Impeller Retainer, 143-215JM, SM, Bore	1	129-771X	
	Impeller Retainer, 254-326JM, LG, Bore	1	129-772X	
* * * * *	Impeller O-Ring, FKM	1	V70220	
	Impeller O-Ring, EPDM	1	E70220	
	Impeller O-Ring, Silicone	1	S75220	
	Impeller O-Ring, FFKM	1	K75220	
	Impeller O-Ring, PTFE ENCAPSULATED	1	T80220	
5	Adapter, 143-184JM Frame, SS	1	122053+	2
	Adapter, 213-215JM Frame, SS	1	122055+	2
	Adapter, 254-256JM Frame, SS	1	122096+	2
	Adapter, 284-326JM Frame, SS	1	122057+	2
7	3/8-16 x 1" Hex Screw, 143-184JM Frame	4	30-30	
	1/2-13 x 1-1/4" Hex Screw, 213-256JM Frame	4	30-36X	
	5/8-11 x 1-1/2" Hex Screw, 284-326JM Frame	4	30-105	
8	3/8" Lockwasher	4	43-28	
	1/2" Lockwasher	4	43-16	
	5/8" Lockwasher	4	43-33	
* * * * *	Casing O-Ring, FKM	1	V70446	
	Casing O-Ring, EPDM	1	E70446	
	Casing O-Ring, Silicone	1	S75446	
	Casing O-Ring, FFKM	1	K75446	
	Casing O-Ring, PTFE ENCAPSULATED	1	T80446	
10	Backplate	1	1-61X	
11	Casing Clamp	1	119-69	
12	Key-3/16", 143-215JM, SM Bore	1	65-3	
	Key-1/4", 254-326JM, LG Bore	1	65-4	

PL5030-CH7

NOTES:

- * **Recommended Spare Parts - available as kits for standard seals-see seal kit pages.**
- 1. Trimmed impellers use the same part number and price; specify the diameter required in 1/8" increments on order.
- 2. Previously supplied as 2 pieces, an adapter and a seal guard; now a single piece.

2105 Pump Parts

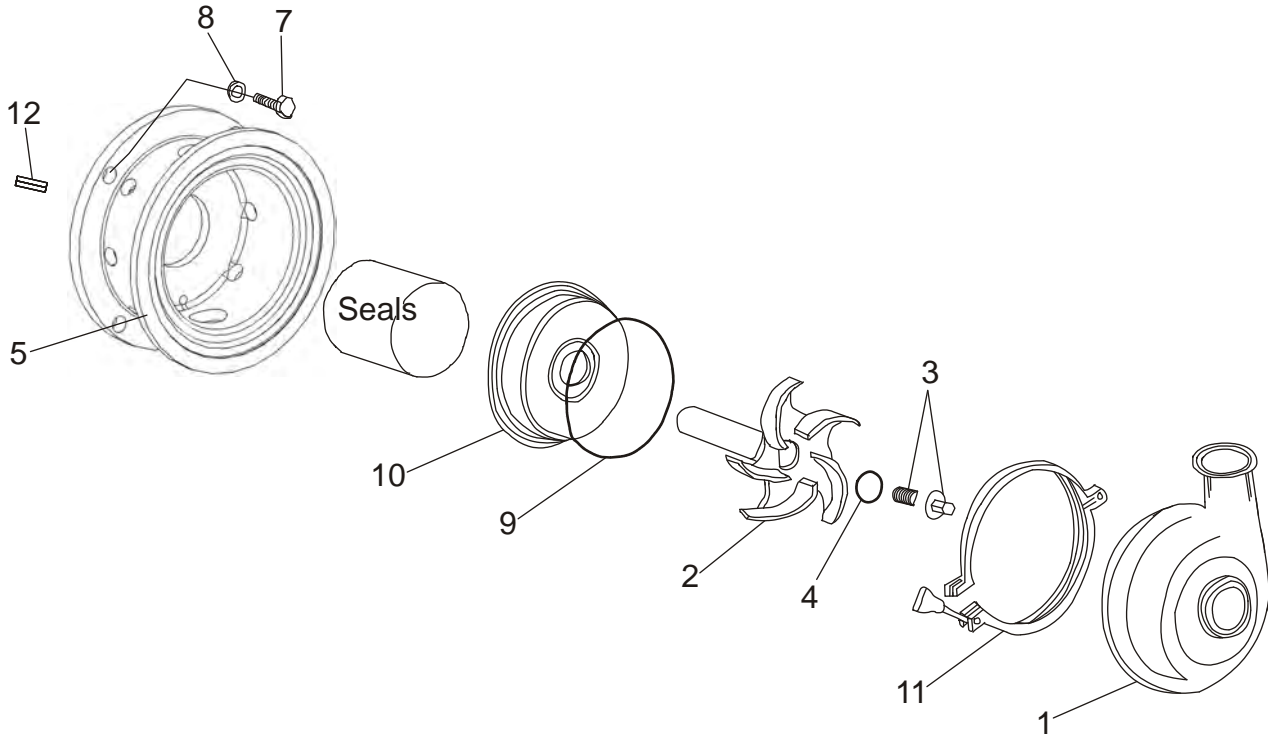

CT100-113a

2105 Casing Parts

FITTING TYPE	SANITARY		NOTES
	4 X 4	6 X 4	
S-Line	CENTPT00645	CENTPT00646	
Bevel Seat	CENTPT00647	N/A	
I-Line; Female	CENTPT00649	CENTPT00650	
I-Line; Male	CENTPT00651	CENTPT00652	
Q-LINE	CENTPT00653	CENTPT00654	
Weld	CENTPT00655	CENTPT00656	
NPT; Male	CENTPT00657	CENTPT00658	1
NPT; Female	CENTPT00659	CENTPT00660	1
150 LB. Flange	CENTPT00661	CENTPT00662	1

PL5030-CH10

NOTES:

1. These casings **do not** meet the requirements of 3A Sanitary Standards.

2105 Pump Parts

ITEM NO.	DESCRIPTION	QTY. PER PUMP	PART NO.	NOTES
1	Casing (see 2105 Casing Parts List)	1		
2	Impeller, 10.5" Dia., 184-215JM Frame SM Bore	1	5-72X	1
	Impeller, 10.5" Dia., 254-326JM Frame LG Bore	1	5-70X	1
3	Impeller Retainer, 184-214JM, SM Bore	1	129-771X	
	Impeller Retainer, 254-326JM, LG Bore	1	129-772X	
* * * * *	Impeller O-Ring, FKM	1	V70220	
	Impeller O-Ring, EPDM	1	E70220	
	Impeller O-Ring, Silicone	1	S75220	
	Impeller O-Ring, FFKM	1	K75220	
	Impeller O-Ring, PTFE ENCAPSULATED	1	T80220	
5	Adapter, 184JM Frame, SS	1	122059+	2
	Adapter, 213-215JM Frame, SS	1	122063+	2
	Adapter, 254-256JM Frame, SS	1	122065+	2
	Adapter, 284-326JM Frame, SS	1	122067+	2
7	3/8-16 x 1" Hex Screw, 184JM Frame	4	30-30	
	1/2-13 x 1-1/4" Hex Screw, 213-256JM Frame	4	30-36X	
	5/8-11 x 1-1/2" Hex Screw, 284-326JM Frame	4	30-105	
8	3/8" Lockwasher	4	43-28	
	1/2" Lockwasher	4	43-16	
	5/8" Lockwasher	4	43-33	
* * * * *	Casing O-Ring, FKM	1	V70450	
	Casing O-Ring, EPDM	1	E70450	
	Casing O-Ring, Silicone	1	S75450	
	Casing O-Ring, FFKM	1	K75450	
	Casing O-Ring, PTFE ENCAPSULATED	1	T80450	
10	Backplate	1	1-29X	
11	Casing Clamp	1	119-223	
12	Key-3/16", 184-215JM, SM Bore	1	65-3	
	Key-1/4", 254-326JM, LG Bore	1	65-4	

PL5030-CH9

NOTES:

- * Recommended Spare Parts - available as kits for standard seals-see seal kit pages.
- 1. Trimmed impellers use the same part number and price; specify the diameter required in 1/8" increments on order.
- 2. Previously supplied as 2 pieces, an adapter and a seal guard; now a single piece.

Style "C" Small Bore Pedestal Mount Parts

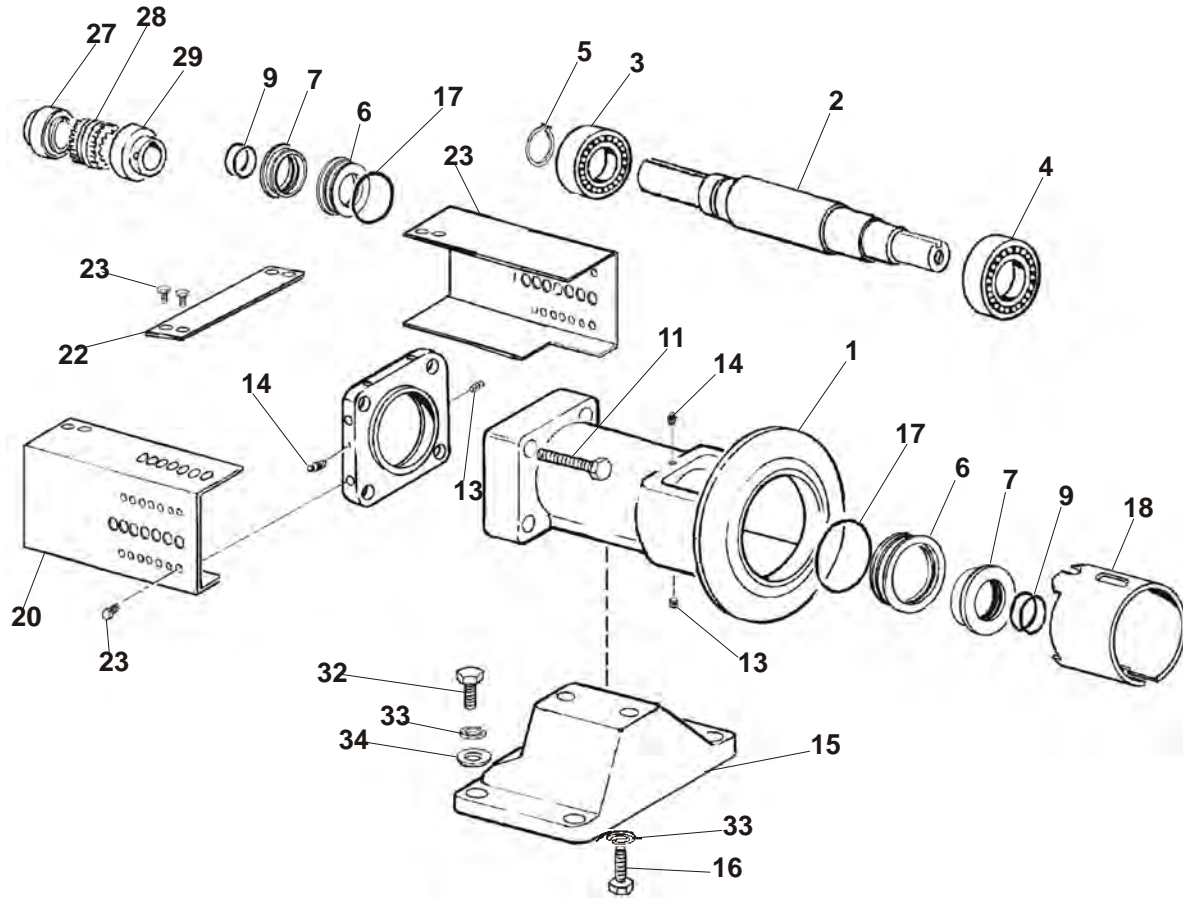

CT100-175

SMALL BORE PEDESTAL FOR:
MP2045 FOR MOTOR FRAME SIZE UP TO 215JM
MP2065LV FOR MOTOR FRAME SIZE UP TO 256T
MP2065 FOR MOTOR FRAME SIZE UP TO 256T
MP2065HV FOR MOTOR FRAME SIZE UP TO 256T
MP2085LV FOR MOTOR FRAME SIZE UP TO 256T
MP2085 FOR MOTOR FRAME SIZE UP TO 256T

Style "C" Small Bore Pedestal Mount Parts

ITEM NO.	DESCRIPTION	QTY. PER PUMP	PART NO.	NOTES
1	Bearing Housing, 2045	1	68-6	
	Bearing Housing, 2065	1	68-7	
	Bearing Housing, 2075 - 2085	1	68-8	
2	Shaft	1	62-528X	
* 3	Rear Bearing	1	23-101	
* 4	Front Bearing	1	23-100	
* 5	Retaining Ring	1	43-139	
6	Seal, Outer	2	23-90	
7	Seal, Inner	2	23-89	
* 9	O-Ring, Inner	4	N70031	
11	1/2-13 x 2 HHCS	4	30-138X	
13	1/4-20 x 3/8" SHSS	2	30-178	
14	Grease Fitting	2	BD0092000	
15	Stand	1	4-34	
16	1/2-13 x 1" HHCS	2	30-78X	
* 17	O-Ring, Outer	2	N70041	
18	Seal Guard, 2045	1	70-32	
	Seal Guard, 2065 / 2085, Small Bore	1	70-33	
20	Cover Coupling, L.H.	1	70-29	
21	Cover Coupling, R.H.	1	70-30	
22	Brace, Cover Coupling	1	2-251	
23	1/4-20 x 1/2" HHCS	8	30-62	
26	End Cap Housing, Small Bore	1	23-92	
27	56 Frame Coupling Half .625W	1	11-37	
	143T-145T Frame Coupling Half .875" 5S	1	11-101	
	182T-184T Frame Coupling Half 1.125" 5S	1	11-102	
	213T-215T Frame Coupling Half 1.375" 6S	1	11-103	
	254T-256T Frame Coupling Half 1.625" 7S	1	11-41	
28	56 Frame Coupling Sleeve 4J	1	11-29	
	143T-184T Frame Coupling Sleeve 5JE	1	11-30	
	213T-215T Frame Coupling Sleeve 6JE	1	11-31	
	254T-256T Frame Coupling Sleeve 7JE	1	11-32	
29	56 Frame Coupling Half 1.0" 4J	1	11-95	
	143T-184T Frame Coupling Half 1.0" 5S	1	11-94	
	213T-215T Frame Coupling Half 1.0" 6S	1	11-96	
	254T-256T Frame Coupling Half 1.0" 7S	1	11-97	
32	1/2-13 x 1-1/2" HHCS	4	30-103	
33	1/2" Washer	6	43-31	
34	1/2" Lockwasher	4	43-16	

PL5030-CH17

NOTES:

* Recommended Spare Parts

Style "C" Large Bore Pedestal Mount Parts

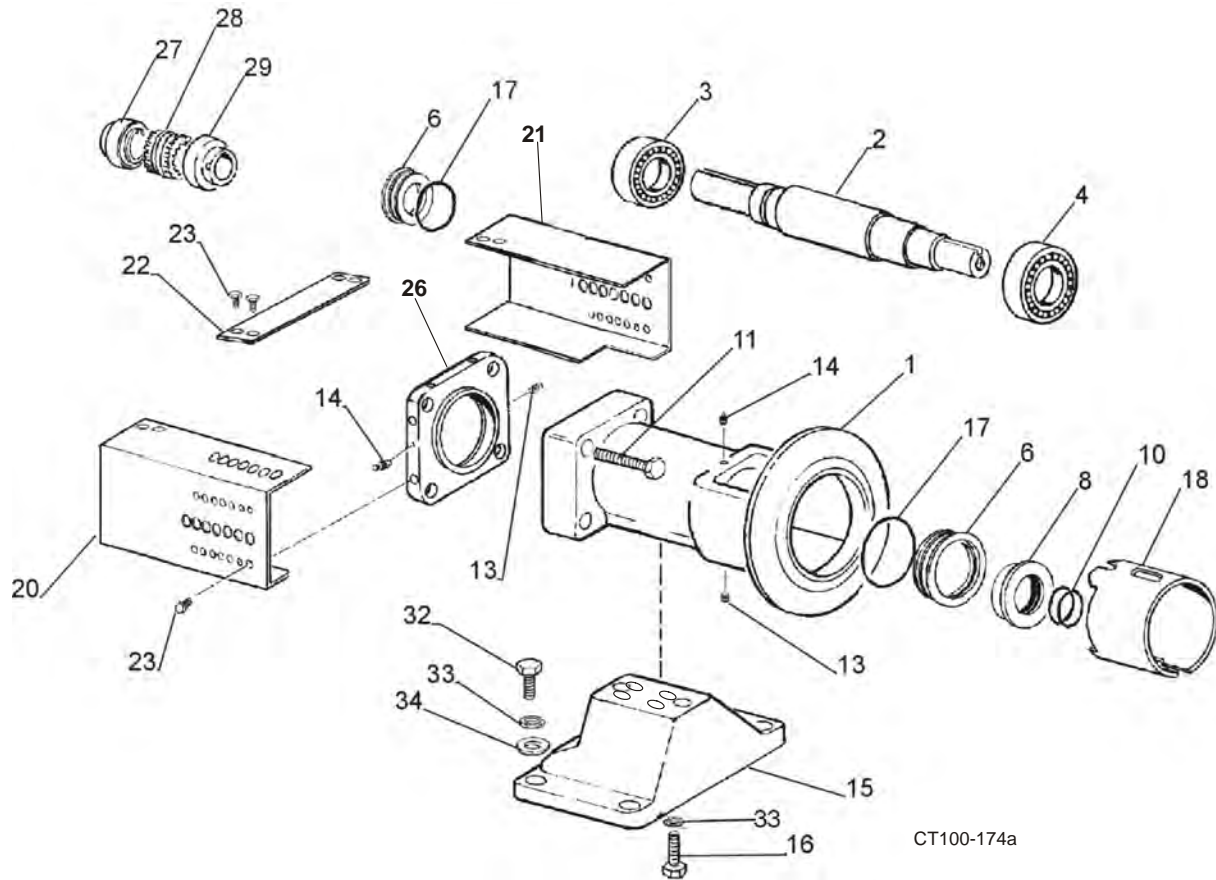

LARGE BORE PEDESTAL FOR:
MP2065 FOR MOTOR FRAME SIZE 284T THROUGH 365T
MP2065HV FOR MOTOR FRAME SIZE 284T THROUGH 365T
MP2085LV FOR MOTOR FRAME SIZE 284T THROUGH 365T
MP2085 FOR MOTOR FRAME SIZE 284T THROUGH 365T
MP2105 FOR MOTOR FRAME SIZE 284T THROUGH 365T

Style "C" Large Bore Pedestal Mount Parts

ITEM NO.	DESCRIPTION	QTY. PER PUMP	PART NO.	NOTES
1	Bearing Housing, 2065	1	68-9	
	Bearing Housing, 2075 - 2085	1	68-10	
	Bearing Housing, 2105	1	68-11	
2	Shaft	1	126985+	
* 3	Rear Bearing	1	23-98	
* 4	Front Bearing	1	CD0036300	
6	Seal, Outer	2	23-95	
8	Seal, Inner	1	23-93	
* 10	O-Ring, Buna N, Inner	2	N70033	
11	1/2-13 x 3-1/4" HHCS	4	30-221X	
13	1/4-20 x 3/8" SHSS	2	30-178	
14	Grease Fitting	2	BD0092000	
15	Stand	1	4-35	
16	1/2-13 x 1-1/4" HHCS	4	30-36X	
* 17	O-Ring, Buna N, Outer	2	N70045	
18	Seal Guard, 2065 / 2085	1	70-33	
	Seal Guard, 2105	1	70-37	
20	Cover Coupling, L.H.	1	70-35	
21	Cover Coupling, R.H.	1	70-36	
22	Brace, Cover Coupling	1	2-252	
23	1/4-20 x 1/2" HHCS	8	30-62	
26	End Cap Housing, Large Bore	1	23-97	
27	213T-215T Frame Coupling Half 1.375" 6S	1	11-103	
	254T-256T Frame Coupling Half 1.625" 7S	1	11-41	
	284T-286T Frame Coupling Half 1.875" 7S	1	11-105	
	324T-326T Frame Coupling Half 2.125" 8S	1	11-106	
	364T-365T Frame Coupling Half 2.375" 8S	1	11-107	
28	213T-215T Frame Coupling Sleeve 6JE	1	11-31	
	254T-286T Frame Coupling Sleeve 7JE	1	11-32	
	324T-326T Frame Coupling Sleeve 8JE	1	11-33	
	364T-365T Frame Coupling Sleeve 8H	1	11-108	
29	213T-215T Coupling Half 1.250" 6S	1	11-98	
	254T-286T Coupling Half 1.250" 7S	1	11-99	
	324T-365T Coupling Half 1.250" 8S	1	11-100	
32	1/2-13 x 1-1/2" HHCS	4	30-103X	
33	1/2" Washer	4	43-31	
34	1/2" Lockwasher	4	43-16	

PL5030-CH18

NOTES:

* Recommended Spare Parts

Motor Mounts

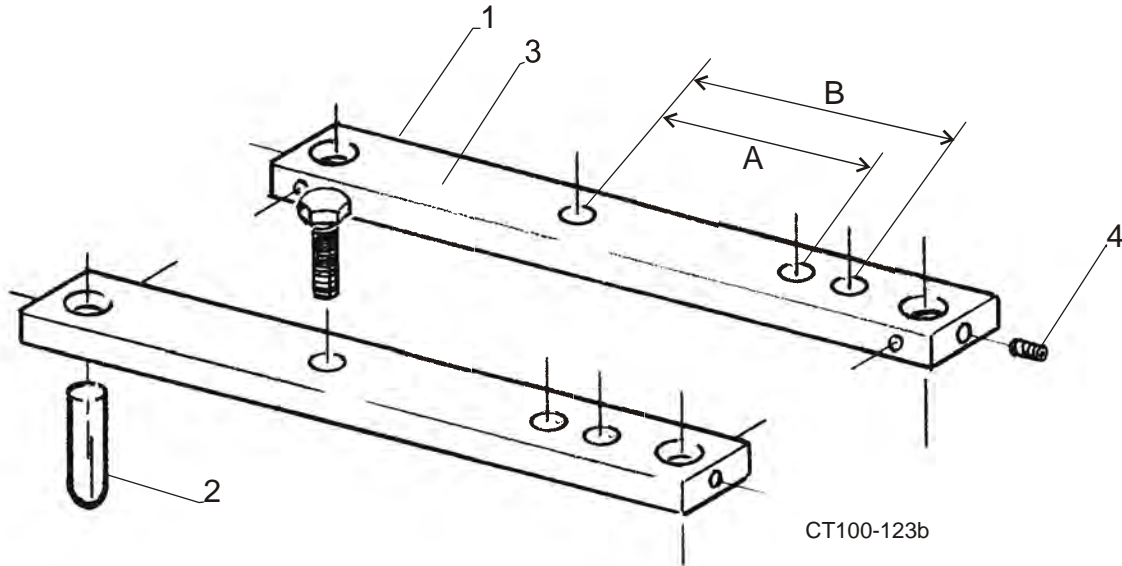

FRAME	COMPLETE MOUNTING KIT	ITEM 1 (BAR) PART NO.	ITEM 2 (LEG) PART NO.	ITEM 3 (HHCS) PART NO.	ITEM 4 (SHSS) PART NO.	"A" DIMENSION (in.)	"B" DIMENSION (in.)
143/145 JM/TC	110256+	110262+	110264+	30-151	30-625	4.0	5.0
182/184 JM/TC	110255+	110261+	110264+	30-30	30-625	4.5	5.5
213/215 JM/TC	110254+	110260+	110264+	30-30	30-625	5.5	7.0
254/256 JM/TC	110253+	110259+	110263+	30-36X	30-626	8.25	10.0
284/286 JM/TC	110252+	110258+	110263+	30-36X	30-626	9.5	11.0
324/326 JM/TC	110251+	110257+	110263+	30-24	30-626	10.5	12.0
364 JM/TC	110251A	110257+	110263+	30-24	30-626	10.5	12.0

PL5030-CH26

Motor Shaft Shims

MOTOR SHAFT SHIM	PART #	MOTOR NEMA FRAME SIZE	QTY.
.005" THICK	35-4	254JM-326JM	AS REQUIRED
.010" THICK	35-5	254JM-326JM	AS REQUIRED
.020" THICK	35-6	254JM-326JM	AS REQUIRED
.005" THICK	35-1	142JM-215JM	AS REQUIRED
.010" THICK	35-2	142JM-215JM	AS REQUIRED
.020" THICK	35-3	142JM-215JM	AS REQUIRED

PL5030-CH27

Troubleshooting

PROBLEM	POSSIBLE CAUSE	SUGGESTED ACTION
Not Enough Liquid Delivered	Pump not primed	Prime pump. Install a priming system if possible.
	Suction or discharge plugged or closed	Open suction. If plugged, shut down pump and remove blockage.
	Air leak in supply or at seal area	Check system for air leaks and repair as necessary. Replace seals if required.
	Wrong direction of rotation	Adjust motor electrical wiring to correct rotation.
	Discharge head too high	Lower discharge head until pump can move material without turning to freely, causing overload.
	Suction lift too high	Lower pump in system until the pump is easily supplied with material.
	Speed too slow (low voltage, wrong frequency, wrong motor)	Adjust voltage and frequency. Change motor if necessary.
	Excessive air in material	Adjust system to remove excess air from material before it reaches the pump.
	Insufficient NPSH (Net Positive Suction Head) available	Adjust system to provide correct NPSH.
	Impeller diameter too small for duty	Contact your Waukesha Cherry-Burrell customer service representative for sizing information. WCB Customer Service: 1-800-252-5200 or 262-728-1900
Not Enough Pressure	Air leak in supply or at seal area	Check system for air leaks and repair as necessary. Replace seals if required.
	Wrong direction of rotation	Adjust motor electrical wiring to correct rotation.
	Speed too slow (low voltage, wrong frequency, wrong motor)	Adjust voltage and frequency. Change motor if necessary.
	Excessive air in material	Adjust system to remove excess air from material before it reaches the pump.
		Impeller diameter too small for duty
Motor Overload	Faulty electrical connections	Check wiring and repair/replace as necessary.
	Unrestricted discharge resulting in too high a flow rate	Add discharge restriction to lower flow rate.
	Impeller interference	Disassemble pump and inspect for damage. Remove interference if still present. Replace worn/damaged parts.
	Seal binding	Disassemble pump and inspect for damage. Check for material crystallization on seals.
	Discharge head too low allowing pump to deliver too much liquid	Raise discharge head until pump achieves proper resistance to flow.

PROBLEM	POSSIBLE CAUSE	SUGGESTED ACTION
Motor Overload	Liquid heavier or more viscous than rating	Contact your Waukesha Cherry-Burrell customer service representative for sizing information. WCB Customer Service: 1-800-252-5200 or 262-728-1900
	Overload heaters too small for motor	Inspect and replace as necessary.
	Electrical supply, voltage, frequency, incorrect	Adjust voltage and frequency. Change motor if necessary.
	Impeller diameter too large for duty	Contact your Waukesha Cherry-Burrell customer service representative for sizing information. WCB Customer Service: 1-800-252-5200 or 262-728-1900
	Defective motor	Replace motor.
Vibration/Noise	Pump not level	Make sure all legs are touching the floor. Level pump.
	Piping not supported	Support all piping as described in the installation section.
	Starved suction/Supply line blocked	Shut down pump and remove blockage.
	Foreign material in pump	Disassemble pump, remove all foreign material and inspect for damage. Replace worn/damaged parts.
	Starved suction/Insufficient NPSH (Net Positive Suction Head) available	Adjust system to provide correct NPSH.
	Impeller hub/impeller shaft worn	Disassemble pump and inspect for damage. Replace worn parts.
	Impeller shaft loose or bent	Disassemble pump and inspect for damage.
	Impeller out of balance	Disassemble pump and inspect for damage. Replace impeller.
	Motor bearings worn	Disassemble motor and inspect for damage. Replace worn parts.
	Starved suction/supply line too long	Shorten system supply line.
	Starved suction/supply line too small	Install larger supply lines.
	Excessive air in material	Adjust system to remove excess air from material before it reaches the pump.
Rapid Seal Wear	Incorrect impeller shaft location; excessive spring loading	Adjust pump alignment to motor and piping.
	Water hammer	Adjust system to reduce air in system and sudden starts or stops in flow.
	Impeller shaft loose or bent	Disassemble pump and inspect for damage. Replace worn/damaged parts.
	Abrasive product	Contact your Waukesha Cherry-Burrell customer service representative for sizing information. WCB Customer Service: 1-800-252-5200 or 262-728-1900

PROBLEM	POSSIBLE CAUSE	SUGGESTED ACTION
Rapid Seal Wear	Prolonged "dry" running	Adjust process to insure pump has a continual fresh supply of product during operation.
	Abrasive solids (unfiltered) in flush water supplied to seal	Use only filtered water in seal flush system.
Seal Leaks	Gasket damaged or worn	Disassemble pump and inspect for damage.
	Seal not installed correctly	Disassemble pump and inspect seal for damage (replace if necessary). Install seal correctly and assemble pump.
	Carbon seal worn or damaged	Disassemble pump and inspect seal for damage (replace if necessary).
	Inlet/Outlet connection loose or no gasket	Inspect Inlet/outlet connection for gasket and tighten connection.
	Casing clamp loose	Tighten clamp.

Notes



Your local contact:



Waukesha Cherry-Burrell, An SPX Brand
611 Sugar Creek Road
Delavan, WI 53115
Phone: (262)728-1900 or (800)252-5200 Fax: (262)728-4904 or (800)252-5012
E-mail: wcb@spx.com

For more information about our worldwide locations, approvals, certifications, and local representatives, please visit www.gowcb.com.

SPX Corporation reserves the right to incorporate our latest design and material changes without notice or obligation. Design features, materials of construction and dimensional data, as described in this bulletin, are provided for your information only and should not be relied upon unless confirmed in writing.