



Read and understand this manual prior to installing, operating or maintaining this pump.



Effective Date
June 8 2000

Waukesha Centrifugal Pump Cart Assembly

Introduction

The purpose of this manual is to provide instructions for the assembly of the WCB centrifugal pump cart.

Read and understand the entire manual before removing from the crate and installing the equipment.

Receiving and Inspection

1. WCB equipment is inspected prior to shipment. When leaving the factory, it is well crated for normal transportation procedures. WCB cannot, however, guarantee safe arrival. Therefore, upon receipt of this equipment, check the received items against the packing list for damage or missing parts. Check the packing material thoroughly for small parts.
2. Visually inspect for damage or loss. Damage or loss should be reported immediately to the delivery carrier while present. Following the immediate notification of the lost or damaged parts, a detailed description including quantity, description of the loss or damage, and a cash value should be claimed against the carrier with respect to the guidelines set forth by the responsible carrier's policies. WCB's responsibility terminates F.O.B. point of manufacture unless otherwise specified per the General Terms and Conditions of Sale as published by WCB and amended from time to time. Contact WCB Order Services if shipping information is required for handling

claims.

3. In the case of damage or loss to the equipment, WCB may perform three major functions:

- a. **Manufacturer Function** – WCB manufactures quality equipment and stands behind the WCB Standard Warranty. Refer to the Standard Warranty.
- b. **Assessor Function** – WCB offers assessment services for filing claims. The WCB assessor will accurately determine the extent of the damage (or loss), and cost of repairs to the equipment. Reimbursement for this service will be agreed upon prior to the assessment.
- c. **Repair House Function** – WCB offers services for repairing the damage(s) or replacement of loss(es) to the equipment. WCB has the option to alter the Standard Warranty on refurbished or replacement parts. The cost of this service will be dependent upon the assessment that is made.

Kit Components

The following items are include with the centrifugal pump cart kit.

- a. Hand Rail -1 (Part # 112510)
- b. Bracket - 4 (Part # 112507)
- c. Bracket Spacers -2 (Part # 112508)
- d. Washers - 4 (Part # 43-169)
- e. Shoulder Bolts - 2 (Part # 30-197)

- f. Cap Screws and Nuts - 2 (Part # 30-138 & 36-38)
- g. Axle Sleeve - 2 (Part # 112464)
- h. Bracket Sleeve - 2 (Part # 112509)
- i. Cap Screws and Nuts - 8 (Part # 30-63 & 36-45)
- j. Wheels -2 (Part # 112513)

If any of these part are missing contact Waukesha Cherry-Burrell customer service for replacement parts.

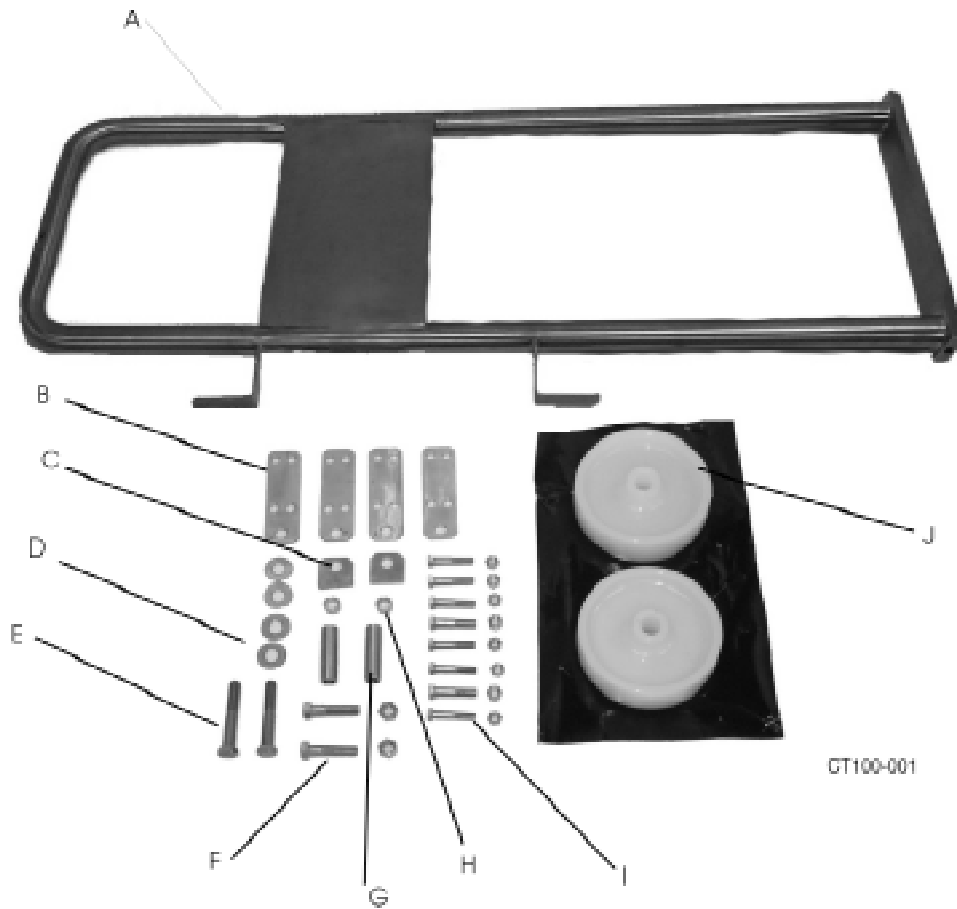

Figure 1. Kit Parts

Assembly

Assembling the Cart

1. Assemble the Axle bolt (item E, Figure 2) with two Washers (items A & D, Figure 2) and the Axle Sleeve (item C, Figure 2) through Wheel (item B, Figure 2).
2. Place the Axle Assembly through the wheel and thread the axle bolt in the bottom rail on the Handrail.
3. Assemble four brackets (loosely) on the handrail base (item A, Figure 3) using four cap screws, 4 nuts and two brackets for each assembly. (see Figure 3).
4. Place the pump on blocking that is approximately 3 inches high (item A, Figure 4).
5. Install the two sleeves (item B, Figure 4) in the leg brackets on the pump and lock in place using the set screw (item C, Figure 4).
6. Raise the handrail and align the pump leg brackets with the bracket assemblies on the handrail base.
7. Place the spacer (item A, Figure 5) between the bottom of the pump leg bracket and bottom bracket piece of the bracket assembly. (See Figure 5).

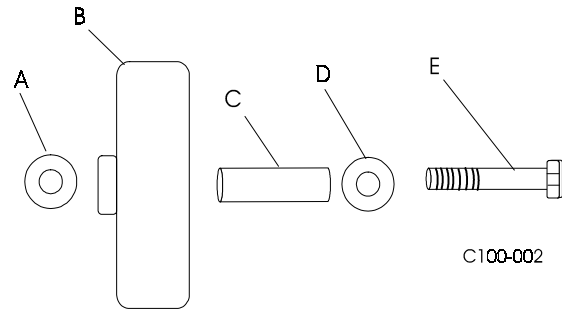

Figure 2. Wheel Assembly

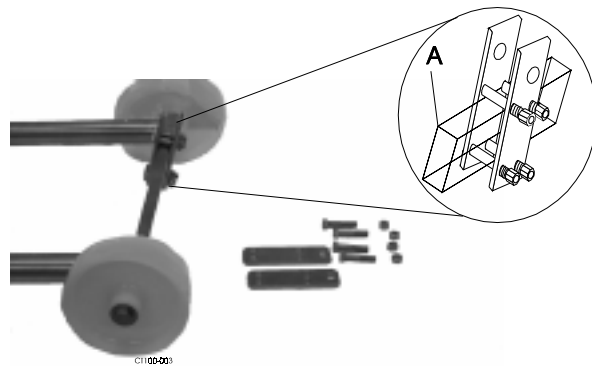

Figure 3. Bracket Assembly

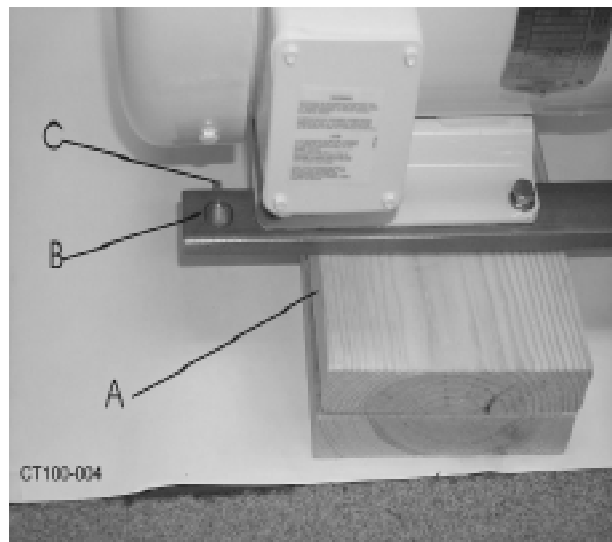

Figure 4. Blocking and Sleeve

8. Install the large bolt and capscrew. (Items B and C, Figure 5).
9. Repeat step 7 for the second pump leg bracket.
10. Center the pump on the the handrail base and tighten the five bolts and cap screws on each bracket assembly.
11. Tilt cart and verify that pump is centered and all cap screws are tight.

Assembly is now complete.

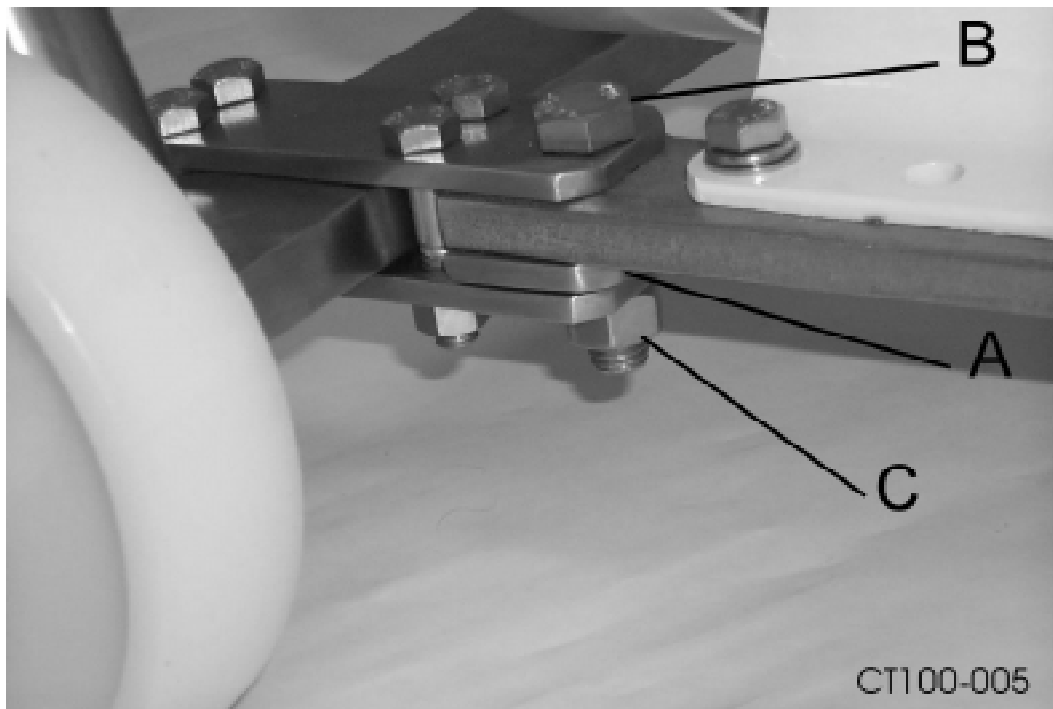

Figure 5. Spacer Location



**Waukesha
Cherry-Burrell**

®

95-03047

611 SUGAR CREEK ROAD
DELAVAN, WI 53115 U.S.A.

CUSTOMER SERVICE TELEPHONE

1-800-252-5200 OR 262-728-1900

TOLL FREE TELEFAX

1-800-252-5012 OR 262-728-4904

Customer Service E-mail address is

custserv@gowcb.com

Visit us at our Web site at www.gowcb.com

Effective Date: **June 8, 2000**