



® An SPX Process Equipment Operation

## Operation and Maintenance Manual S200 Series Centrifugal Pumps



**Read and understand this manual  
prior to installing, operating or servicing this equipment.**





611 Sugar Creek Road  
Delavan, WI 53115 USA

Tel: (800) 252-5200 or (262) 728-1900  
Fax: (800) 252-5012 or (262) 728-4904

E-mail: [info@processequipment.spx.com](mailto:info@processequipment.spx.com)  
Web site: [www.spxprocessequipment.com](http://www.spxprocessequipment.com)

Information contained in this manual is subject to change without notice and does not represent a commitment on the part of Waukesha Cherry-Burrell. No part of this manual may be reproduced or transmitted in any form or by any means, electronic or mechanical, including photocopying and recording, for any purpose, without the express written permission of Waukesha Cherry-Burrell.

Copyright © 2005 All Rights Reserved.

Issued Date: **January 2005**

Revision Date: **June 2005**

Publication: **95-03080**

# Table of Contents

<b>Waukesha Cherry-Burrell Warranty .....</b>	<b>6</b>
Shipping Damage or Loss .....	6
Warranty Claim .....	6
<b>Safety .....</b>	<b>7</b>
<b>Care of Stainless Steel .....</b>	<b>8</b>
Stainless Steel Corrosion .....	8
Alloy 88 .....	8
Elastomer Seal Replacement Following Passivation .....	8
<b>Introduction .....</b>	<b>9</b>
Manual Content .....	9
Factory Inspection .....	9
Receiving Your Pump .....	9
Receiving and Inspection .....	9
Pump Characteristics .....	9
S200 Series Base Mount Description .....	10
Base Mount Components .....	10
Motor Adapter .....	10
Stand .....	10
Base (Optional) .....	10
Performance Characteristics .....	13
Quality Control .....	13
Authorization .....	13
Standard Construction .....	13
Construction Options .....	13
Operating Parameters .....	13
S200 Series Capacities .....	14
Dimensions .....	15
Centrifugal S200 Series Pump and Pedestal Weights .....	21
<b>Installation .....</b>	<b>23</b>
Pump Location .....	23
Pump Leveling .....	23
Supply and Discharge Piping/Valves .....	23
Installations That May Cause Operation Problems .....	24
Electrical Connections .....	25
Flush Seal Option .....	25
Type 4 Seal .....	25
Before First Startup .....	25
Clean Pump and Piping .....	25
Cleaning Safety Procedures .....	26
Manual Cleaning .....	26
Cleaning-In-Place (CIP) .....	26
Preliminary Test Run .....	26
Ammeter Test .....	26

# Table of Contents

<b>Operation .....</b>	<b>27</b>
Starting the Pump .....	27
Priming the Pump .....	27
Priming the Pump With the Feed Source Above Pump Level .....	27
Priming the Pump With the Feed Source Below Pump Level .....	27
Stopping the Pump .....	27
<b>Maintenance .....</b>	<b>28</b>
Scheduled Maintenance .....	28
Routine Maintenance .....	28
Disassembly of Pump With a Type 1 Seal .....	28
Removal of the Water Cascade .....	28
Inspect Parts .....	29
Assembly of Pump With a Type 1 Seal .....	30
Backplate Assembly .....	30
Backplate/Impeller Assembly .....	30
Disassembly Type 4 Seal .....	33
Removal of the Water Cascade .....	33
Standard Seal Dimensions .....	37
Disassembly of Modular Base Mounted Pumps .....	38
Disassembling The Outer Seal Assemblies .....	38
Assembling the Outer Seal Assemblies .....	39
Pre-assembled (Cartridge) Seals .....	39
Disassembly of Pre-assembled (Cartridge) Seals .....	39
Assembly of a Pump With Pre-assembled (Cartridge) Seals .....	40
Pedestal Base Mounted Pump Housing Lubrication .....	42
Lubrication Schedule .....	42
Cartridge Seal .....	43
Servicing the Electric Motor .....	44
General Service Information .....	44
Motor Lubrication Instructions .....	44
<b>Parts Lists .....</b>	<b>45</b>
Seal Kits .....	45
Basic Seal Kit - Type 1 Seal - Sanitary Pump Model .....	45
Complete Seal Kit - Type 1 Seal - Sanitary Pump Model .....	45
Basic Seal Kit - Type 4 Seal - Sanitary Pump Model .....	46
Complete Seal Kit - Type 4 Seal - Sanitary Pump Model .....	46
<b>Troubleshooting .....</b>	<b>67</b>

## **Waukesha Cherry-Burrell Warranty**

Seller warrants its products to be free from defect in materials and workmanship for a period of one (1) year from the date of shipment. This warranty shall not apply to products which require repair or replacement due to normal wear and tear or to products which are subjected to accident, misuse or improper maintenance. This warranty extends only to the original Buyer. Products manufactured by others but furnished by Seller are exempted from this warranty and are limited to the original manufacturer's warranty.

Seller's sole obligation under this warranty shall be to repair or replace any products that Seller determines, in its discretion, to be defective. Seller reserves the right either to inspect the products in the field or to request their prepaid return to Seller. Seller shall not be responsible for any transportation charges, duty, taxes, freight, labor or other costs. The cost of removing and/or installing products which have been repaired or replaced shall be at Buyer's expense.

Seller expressly disclaims all other warranties, express or implied, including without limitation any warranty of merchantability of fitness for a particular purpose. The foregoing sets forth Seller's entire and exclusive liability, and Buyer's exclusive and sole remedy, for any claim of damages in connection with the sale of products. In no event shall Seller be liable for any special consequential incidental or indirect damages (including without limitation attorney's fees and expenses), nor shall Seller be liable for any loss of profit or material arising out of or relating to the sale or operation of the products based on contract, tort (including negligence), strict liability or otherwise.

### **Shipping Damage or Loss**

If equipment is damaged or lost in transit, file a claim at once with the delivering carrier. The carrier has signed the Bill of Lading acknowledging that the shipment has been received from WCB in good condition. WCB is not responsible for the collection of claims or replacement of materials due to transit shortages or damages.

### **Warranty Claim**

Warranty claims must have a **Returned Goods Authorization (RGA)** from the Seller before returns will be accepted.

Claims for shortages or other errors, exclusive of transit shortages or damages, must be made in writing to Seller within ten (10) days after delivery. Failure to give such notice shall constitute acceptance and waiver of all such claims by Buyer.

## Safety

### READ AND UNDERSTAND THIS MANUAL PRIOR TO INSTALLING, OPERATING OR SERVICING THIS EQUIPMENT

Waukesha Cherry-Burrell recommends users of our equipment and designs follow the latest Industrial Safety Standards. At a minimum, these should include the industrial safety requirements established by:

1. Occupational Safety and Health Administration (OSHA), Title 29 of the CFR  
Section 1910.212- General Requirements for all Machines
2. National Fire Protection Association, ANSI/NFPA 79  
ANSI/NFPA 79- Electrical Standards for Industrial Machinery
3. National Electrical Code, ANSI/NFPA 70  
ANSI/NFPA 70- National Electrical Code  
ANSI/NFPA 70E- Electrical Safety Requirement for Employee Workplaces
4. American National Standards Institute, Section B11

**Attention:** Servicing energized industrial equipment can be hazardous. Severe injury or death can result from electrical shock, burn, or unintended actuation of controlled equipment. Recommended practice is to disconnect and lockout industrial equipment from power sources, and release stored energy, if present. Refer to the National Fire Protection Association Standard No. NFPA70E, Part II and (as applicable) OSHA rules for Control of Hazardous Energy Sources (Lockout-Tagout) and OSHA Electrical Safety Related Work Practices, including procedural requirements for:

- Lockout-tagout
- Personnel qualifications and training requirements
- When it is not feasible to de-energize and lockout-tagout electrical circuits and equipment before working on or near exposed circuit parts

**Locking and Interlocking Devices:** These devices should be checked for proper working condition and capability of performing their intended functions. Make replacements only with the original manufacturer's renewal parts or kits. Adjust or repair in accordance with the manufacturer's instructions.

**Periodic Inspection:** Industrial equipment should be inspected periodically. Inspection intervals should be based on environmental and operating conditions and adjusted as indicated by experience. At a minimum, an initial inspection within 3 to 4 months after installation is recommended. Inspection of the electrical control systems should meet the recommendations as specified in the National Electrical Manufacturers Association (NEMA) Standard No. ICS 1.3, Preventative Maintenance of Industrial Control and Systems Equipment, for the general guidelines for setting-up a periodic maintenance program.

**Replacement Equipment:** Use only replacement parts and devices recommended by the manufacturer to maintain the integrity of the equipment. Make sure the parts are properly matched to the equipment series, model, serial number, and revision level of the equipment.

Warnings and cautions are provided in this manual to help avoid serious injury and/or possible damage to equipment:



**DANGER:** marked with a stop sign.  
Immediate hazards which **WILL** result in severe personal injury or death.



**WARNING:** marked with a warning triangle.  
Hazards or unsafe practices which **COULD** result in severe personal injury or death.



**CAUTION:** marked with a warning triangle.  
Hazards or unsafe practices which **COULD** result in minor personal injury or product or property damage.

## **Care of Stainless Steel**

### **Stainless Steel Corrosion**

Corrosion resistance is greatest when a layer of oxide film is formed on the surface of stainless steel. If film is disturbed or destroyed, stainless steel becomes much less resistant to corrosion and may rust, pit or crack.

Corrosion pitting, rusting and stress cracks may occur due to chemical attack. Use only cleaning chemicals specified by a reputable chemical manufacturer for use with 300 series stainless steel. Do not use excessive concentrations, temperatures or exposure times. Avoid contact with highly corrosive acids such as hydrofluoric, hydrochloric or sulfuric. Also avoid prolonged contact with chloride-containing chemicals, especially in presence of acid. If chlorine-based sanitizers are used, such as sodium hypochlorite (bleach), do not exceed concentrations of 150 ppm available chlorine, do not exceed contact time of 20 minutes, and do not exceed temperatures of 104°F (40°C).

Corrosion discoloration, deposits or pitting may occur under product deposits or under gaskets. Keep surfaces clean, including those under gaskets or in grooves or tight corners. Clean immediately after use. Do not allow equipment to set idle, exposed to air with accumulated foreign material on the surface.

Corrosion pitting may occur when stray electrical currents come in contact with moist stainless steel. Ensure all electrical devices connected to the equipment are correctly grounded.

### **Alloy 88**

Waukesha Alloy 88 is the standard rotor material for Universal I, Universal II, Universal Lobe, Universal 420/520 and 5000 Series Rotary PD pumps. This alloy was developed specifically for corrosion resistance and close operating clearance requirements of high performance rotary positive displacement pumps. Alloy 88 is a nickel based, corrosion-resistant, non-galling or seizing material. The ASTM designation is A494 Grade CY5SnBiM (UNS N26055), and the material is listed in the 3-A Sanitary Standards as acceptable for product contact surfaces.

The above properties make Alloy 88 the ideal material for Waukesha stainless steel PD pumps. The non-galling rotors permit close operating clearances in the liquid end. This provides low slip and minimum shear damage. The rotors will not gall or seize if they come in contact with the body or cover during operation.

The corrosion resistance of Alloy 88 is approximately equal to AISI 300 Series Stainless Steel. However, Alloy 88 has limited resistance to certain aggressive chemicals that may be commonly used in contact with AISI 300 Series Stainless Steel.

Do not use Alloy 88 in contact with nitric acid. Nitric acid is commonly used to passivate new installations of stainless steel equipment. Do not allow nitric acid based passivation chemicals to contact Alloy 88 rotors. Remove the rotors during passivation and use a separate pump to circulate the passivation chemicals. Also, if nitric acid-based CIP cleaning chemicals are used, remove the rotors prior to CIP cleaning and clean them separately by hand in a mild detergent.

If you have questions regarding other aggressive chemicals, please contact Waukesha Cherry-Burrell Application Engineering for assistance.

### **Elastomer Seal Replacement Following Passivation**

Passivation chemicals can damage product contact areas of WCB equipment. Elastomers (rubber components) are most likely to be affected. Always inspect all elastomer seals after passivation is completed. Replace any seals showing signs of chemical attack. Indications may include swelling, cracks, loss of elasticity or any other noticeable changes when compared with new components.

## **Introduction**

### **Manual Content**

Maintenance procedures in this manual do not cover aseptic or high pressure pump applications. These are covered in special addendums available from your Waukesha Cherry-Burrell representative.

### **Factory Inspection**

Each Waukesha pump is shipped completely assembled, lubricated and ready for use. (Make sure you review "Operation" on page 27 before operating your pump).

### **Receiving Your Pump**

All ports are covered at the factory to keep out foreign objects during transit. If the covers are missing or damaged, a thorough inspection of fluid head, by removing the pump cover, is recommended. Be sure pumping head is clean and free of foreign material before rotating shaft.

### **Receiving and Inspection**

1. WCB equipment is run tested or inspected prior to shipment. When leaving the factory, it is well crated for normal transportation procedures. WCB cannot, however, guarantee safe arrival. Therefore, upon receipt of this equipment, check the received items against the packing list for damaged or missing parts. Check the packing material thoroughly for small parts.
2. Visually inspect for damage or loss. Damage or loss should be reported immediately to the delivery carrier while present. Following the immediate notification of the lost or damaged parts, a detailed description of the loss or damage, and a cash value should be claimed against the carrier. WCB's responsibility terminates F.O.B. point of manufacture unless otherwise specified per the General Terms and Conditions of Sale as published by WCB and amended from time to time. Contact WCB Order Services if shipping information is required for handling claims.
3. In the case of damage or loss to the equipment, WCB may perform three major functions:
  - Manufacturer Function - WCB manufactures quality equipment and stands behind the WCB Standard Warranty. Refer to the Standard Warranty.

- Assessor Function - WCB offers assessment services for filing claims. The WCB assessor will accurately determine the extent of the damage (or loss), and cost of repairs to the equipment. Reimbursement for this service will be agreed upon prior to the assessment.
- Repair House Function -WCB offers services for repairing the damage(s) or replacement of loss(es) to the equipment. WCB has the option to alter the Standard Warranty on refurbished or replacement parts. The cost of this service will be dependent upon the assessment that is made.

### **Pump Characteristics**

The Waukesha S200 Series Pump is built for extremely durable service. The casing, backplate and impeller/stub shaft are machined from 316L stainless steel for extra strength and resistance to line shock and corrosion. Large bearings and shaft provide positive alignment and minimize vibration.

The casing is clamped to the motor adapter bracket (close coupled) or bearing housing (base mount) for easy disassembly while permitting 360 degree rotation of the discharge port.

S200 Series pumps are available with three standard seal types.

- Type 1- Single mechanical seal, external mounted and balanced.
- Type 1C- Single mechanical seal with water cascade flush.
- Type 4 - Double mechanical seal with flush housing.

All seal components are interchangeable between models. All seal assemblies utilize an externally mounted, balanced rotary seal for longer seal life and better sealing capability. The stationary seal face is reversible and replaceable.

S200 Series pumps are designed for a broad range of sanitary and industrial applications. Sanitary models are designed for clean-in-place and meet U.S.D.A. and 3A Standards.

## **S200 Series Base Mount Description**

The Waukesha S200 Series Modular Base Mounted Centrifugal Pump design consists of four components (in addition to pump and motor). These components are used in various combinations and arrangements to provide flexibility to meet various needs.

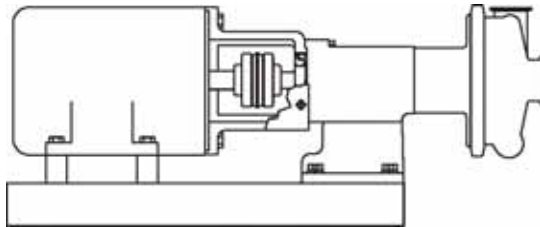
### **Base Mount Components**

#### ***Bearing Housing (Pump Adapter)***

- Bearing housing is made of epoxy coated cast iron w/ 316 SS shaft, ball bearings.
- The adapter mounts to the pump components (same components used for close coupled pumps).
- Bearing housing also includes coupling for motor shaft plus guards used in style "B" & "C" arrangements.

#### ***Style "B" Arrangement***

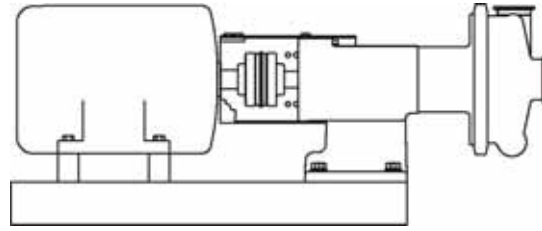
The style "B" arrangement is composed of the bearing housing, motor adapter and pedestal stand attached to bearing housing; for use with NEMA C-face motors. All motors must have feet for attachment of supports. (Figure 1).



***Figure 1 - Style B***

#### ***Style "C" Arrangement***

The style "C" arrangement is composed of the bearing housing, guard and pedestal stand attached to bearing housing; for use with foot mounted T-frame motors. Pump and motor are mounted and supported independently. (Figure 2).



***Figure 2 - Style C***

### **Motor Adapter**

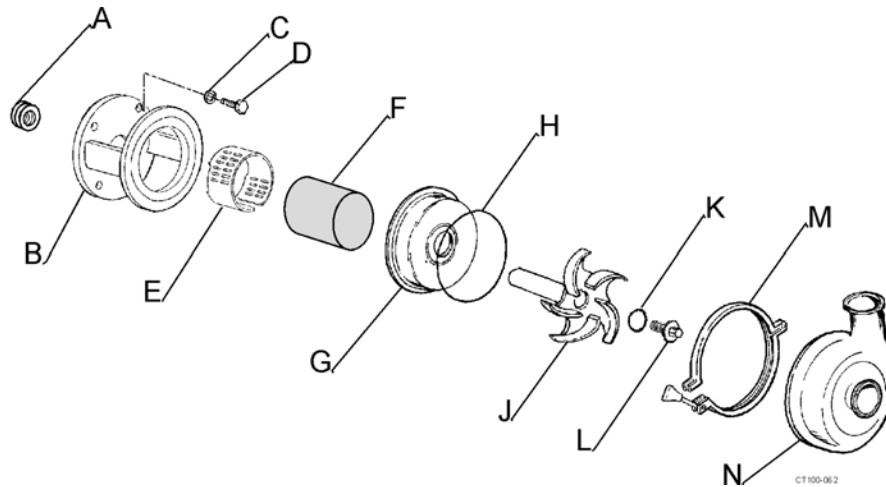
- The motor adapter is made of epoxy coated cast iron.
- The motor adapter is used to mount a std. NEMA C-face motor onto bearing housing.
- The motor adapter is used to provide an accurate, rigid shaft alignment.
- The motor adapter is used in style "B" arrangements.

### **Stand**

- The stand (pedestal) is made of epoxy coated cast iron.
- The stand attaches under motor adapter or bearing housing.

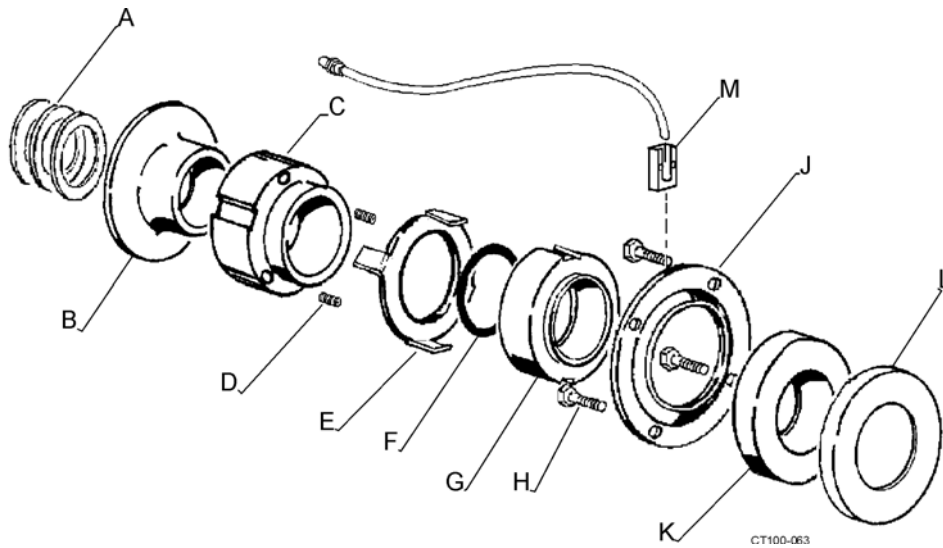
### **Base (Optional)**

- The epoxy coated channel base - used in style "B" & "C" arrangements. See "Table of Base Size Used On Pedestal Mounted Centrifugal Pumps" on page 19.



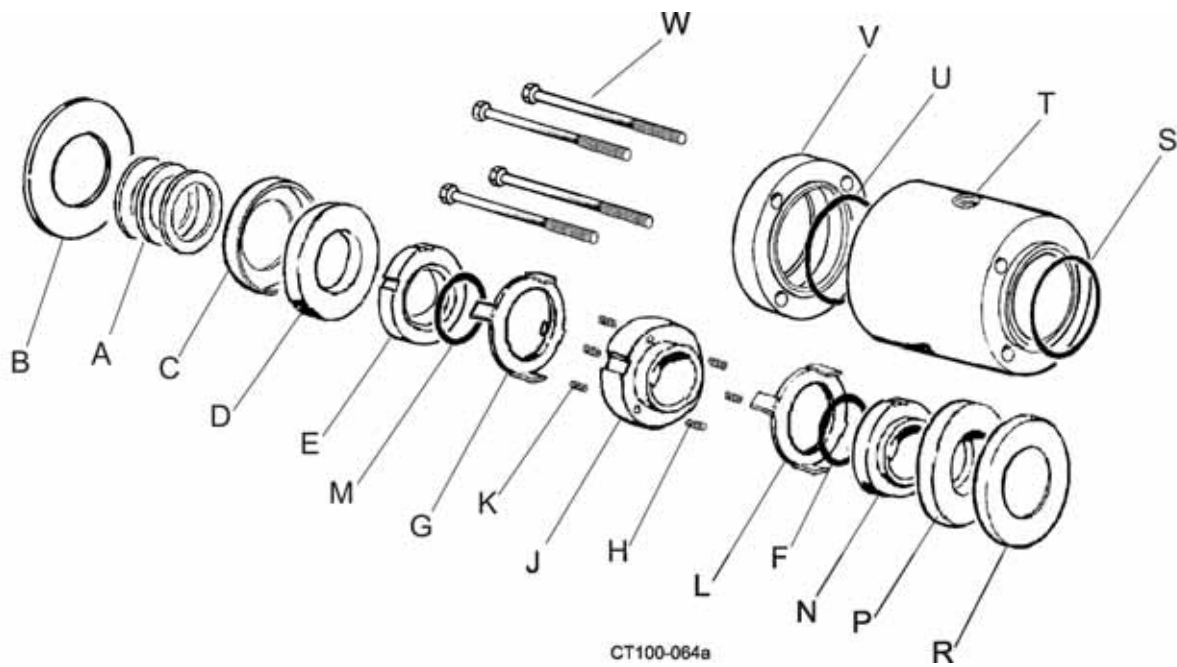
**Figure 3 - Common Part Identification**

- |                             |                      |
|-----------------------------|----------------------|
| A. Motor Shims              | H. O-ring            |
| B. Motor Adaptor            | J. Impeller          |
| C. Lock Washer              | K. O-ring            |
| D. Cap Screws               | L. Impeller Retainer |
| E. Seal Guard               | M. Clamp             |
| F. Seals (detail not shown) | N. Casing            |
| G. Backplate                |                      |



**Figure 4 - Common Part Identification**

- |                    |                        |
|--------------------|------------------------|
| A. Motor Shims     | G. Rotary Seal         |
| B. Deflector       | H. Cap Screws          |
| C. Spring Retainer | J. Seat Retainer       |
| D. Springs         | K. Stationary Seal     |
| E. Tabbed Washer   | L. L-gasket            |
| F. O-ring          | M. Water Cascade Block |



**Figure 5 - Common Part Identification**

- |                    |                    |
|--------------------|--------------------|
| A. Motor Shims     | L. Tabbed Washer   |
| B. Slinger         | M. O-ring          |
| C. L-gasket        | N. Rotary Seal     |
| D. Stationary Seal | P. Stationary Seal |
| E. Rotary Seal     | R. L-gasket        |
| F. O-ring          | S. O-ring          |
| G. Tabbed Washer   | T. Housing         |
| H. Springs         | U. O-ring          |
| J. Spring Retainer | V. Seat Retainer   |
| K. Springs         | W. Cap Screws      |

**Performance Characteristics****Quality Control**

Each pump undergoes a performance test for design flow rate and design pressure prior to shipment.

**Authorization**

3A/USDA (Sanitary Models)

**Standard Construction**

- Casing: 316L Stainless Steel.
- Port Connections: S-Line.
- Backplate: 316L Stainless Steel.
- Impeller W/Integral Shaft: 316L Stainless Steel.
- Impeller Retainer: 316L Stainless Steel.
- Shaft Seal: Single Mechanical, external balanced (Type 1).
- Rotary Seal Material: Carbon.
- Stationary Seal: Purebide
- Elastomers: FDA approved FKM.
- Finish: All product contact surfaces provided with a sanitary polish (20Ra mechanical). The motor adapter bracket is Nedox coated cast iron.
- Mounting: Close coupled for JM shafted motors.

**Construction Options****Ports**

Buttweld  
Flange 150# MSS  
Flange 150# ASA  
DIN  
DIN Form A  
SMS

**Seal Type**

- Water Cascade (Type 1C).
- Double Mechanical w/flush (Type 4 Shaft Seal).
- WFI - Special Type 4 shaft seal for water for injection applications.
- Commercially available seals (Contact your WCB representative for details).

**Rotary Seal Material**

Purebide  
Silicone Carbide  
Tungsten Carbide

**Stationary Seal**

Silicone Carbide  
Tungsten Carbide

**Elastomers**

EPDM (FDA approved)  
Silicone (FDA approved)  
Teflon Encapsulated (FDA approved)  
FKM  
FFKM

**Finishes/Product Contact Surfaces**

15RA  
20RA  
Electropolish

**Leg Kit**

See "Motor Mounts" on page 60.

**Base Mounting**

Footed C-face motors  
T-Frame motors. **Note:** T-Frame motors can be configured with or without bases, couplings or coupling covers.

**Pedestal Mounted**

Two types of stands see "Base Mount Components" on page 10.

**Motors**

NEMA JM (standard) totally enclosed fan cooled (TEFC) for close-coupled pumps.

1750 or 3500 RPM single phase 115/230 volt and 3 phase 230/460 volt.

**Optional Enclosures**

Washdown  
Explosion proof  
Severe Duty/Chemical Duty

**Operating Parameters****Nominal Capacity**

Up to 900 U.S. GPM (204 Cubic Meters/Hr.)

**Viscosity**

Up to 1500 CPS

**Differential Pressure**

UP to 340 Feet (100 Meters)

**Temperature**

Up to 450°F (230°C)

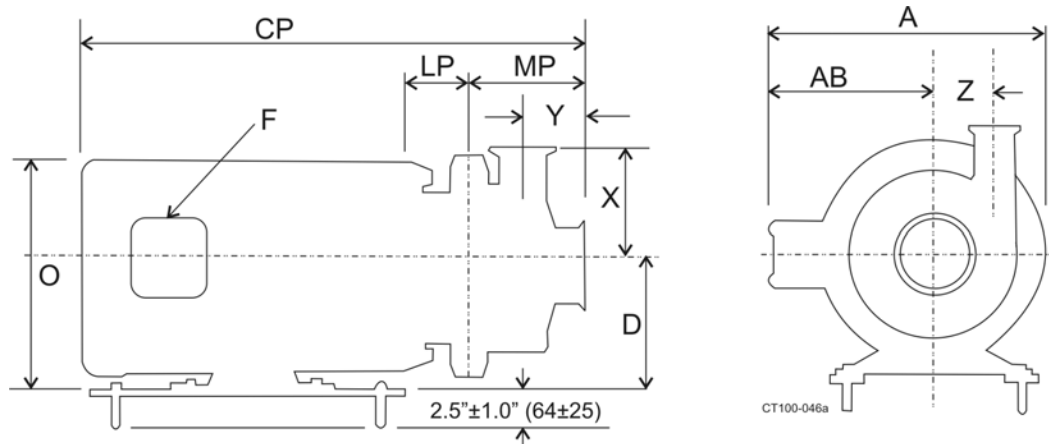
**Nominal Speeds**

1450 or 2900 RPM - 50HZ  
1750 or 3500 RPM - 60HZ

**S200 Series Capacities**

<b>SANITARY MODEL</b>	<b>INLET SIZE INCH (MM)</b>	<b>OUTLET SIZE INCH (MM)</b>	<b>MAXIMUM CAPACITY GPM (M3/HR)</b>
<b>S2045</b>	1.5 (40)	1.5 (40)	190 GPM (43)
	2.0 (50)	1.5 (40)	190 GPM (43)
<b>S2065LV</b>	1.5 (40)	1.5 (40)	195 GPM (44)
	2.0 (50)	1.5 (40)	195 GPM (44)
	2.5 (65)	1.5 (40)	194 GPM (44)
<b>S2065</b>	2.5 (65)	2.0 (50)	400 GPM (91)
<b>S2065HV</b>	3.0 (75)	2.0 (50)	500 GPM (114)
<b>S2075</b>	3.0 (75)	1.5 (40)	300 GPM (68)
<b>S2085LV</b>	2.0 (50)	1.5 (40)	140 GPM (32)
<b>S2085</b>	3.0 (75)	2.5 (65)	900 GPM (204)
	4.0 (100)	2.5 (65)	900 GPM (204)
<b>S2092</b>	3.0 (75)	2.0 (50)	700 GPM (159)

**Dimensions**



**Figure 6 - Foot Print Dimensions**

**Table 1: Table of Dimensions for Figure 6**

Frame	A inch (mm)	O inch (mm)	D inch (mm)	F inch (mm)	AB inch (mm)
<b>145JM</b>	9.32 (237)	7.1 (180)	3.5 (89)	.88 (22)	5.73 (145)
<b>182JM</b>	9.32 (237)	8.1 (206)	4.5 (114)	.88 (22)	5.73 (145)
<b>184JM</b>	11.11 (282)	8.49 (216)	4.5 (114)	1.09 (28)	6.87 (174)
<b>213JM</b>	13.18 (335)	10.39 (264)	5.25 (133)	1.38 (35)	8.04 (204)
<b>215JM</b>	13.18 (335)	10.39 (264)	5.25 (133)	1.38 (35)	8.04 (204)
<b>254JM</b>	15.34 (390)	11.39 (289)	6.25 (159)	1.38 (35)	9.40 (239)
<b>256JM</b>	15.34 (390)	11.39 (289)	6.25 (159)	1.38 (35)	9.40 (239)
<b>284JM</b>	20.78 (528)	14.44 (367)	7.0 (178)	2.0 (51)	13.12 (333)
<b>286JM</b>	20.49 (520)	14.44 (367)	7.0 (178)	2.0 (51)	13.12 (333)
<b>324JM</b>	23.05 (585)	16.25 (413)	8.0 (203)	2.5 (63)	14.61 (371)
<b>326JM</b>	23.05 (585)	16.25 (413)	8.0 (203)	2.5 (63)	14.61 (371)

*NOTE: Figure 6 dimensions for the Inlet, Outlet, items X,Y and Z are listed in Table 4 on page 17.*

**Table 2: Table of Dimensions for Figure 6**

FRAME	PUMP SIZE							
	S2045		S2065		S2065LV		S2065HV	
	LP	CP	LP	CP	LP	CP	LP	CP
	Inches (mm)	Inches (mm)	Inches (mm)	Inches (mm)	Inches (mm)	Inches (mm)	Inches (mm)	Inches (mm)
<b>145JM</b>	2.92 (74)	18.18 (461)	2.71 (69)	18.43 (468)	2.71 (69)	17.93 (455)	2.71 (69)	18.85 (479)
<b>182JM</b>	2.92 (74)	19.56 (497)	2.71 (69)	19.81 (503)	2.71 (69)	19.31 (490)	2.71 (69)	20.23 (514)
<b>184JM</b>	2.92 (74)	20.81 (529)	2.71 (69)	21.01 (534)	2.71 (69)	20.56 (522)	2.71 (69)	21.43 (544)
<b>213JM</b>	-	-	2.97 (75)	22.81 (579)	2.97 (75)	22.31 (567)	2.97 (75)	23.23 (590)
<b>215JM</b>	-	-	2.97 (75)	23.94 (608)	2.97 (75)	23.44 (595)	2.97 (75)	24.36 (618)
<b>254JM</b>	-	-	3.97 (101)	26.07 (662)	3.97 (101)	25.57 (649)	3.97 (101)	26.49 (673)
<b>256JM</b>	-	-	3.97 (101)	27.83 (707)	3.97 (101)	27.33 (694)	3.97 (101)	28.25 (718)
<b>284JM</b>	-	-	3.97 (101)	31.43 (798)	3.97 (101)	30.93 (786)	3.97 (101)	31.85 (809)
<b>286JM</b>	-	-	3.97 (101)	31.64 (804)	3.97 (101)	31.14 (791)	3.97 (101)	32.06 (814)
<b>324JM</b>	-	-	-	-	-	-	-	-
<b>326JM</b>	-	-	-	-	-	-	-	-

**Table 3: Table of Dimensions for Figure 6**

FRAME	PUMP SIZE							
	S2075		S2085		S2085LV		S2092	
	LP	CP	LP	CP	LP	CP	LP	CP
	Inches (mm)	Inches (mm)	Inches (mm)	Inches (mm)	Inches (mm)	Inches (mm)	Inches (mm)	Inches (mm)
<b>145JM</b>	2.75 (70)	18.17 (461)	2.75 (70)	18.84 (478)	2.75 (70)	18.17 (461)	2.75 (70)	18.78 (477)
<b>182JM</b>	2.75 (70)	19.55 (497)	2.75 (70)	21.21 (513)	2.75 (70)	19.55 (497)	2.75 (70)	20.16 (512)
<b>184JM</b>	2.75 (70)	20.80 (528)	2.75 (70)	21.46 (545)	2.75 (70)	20.80 (528)	2.75 (70)	21.41 (544)
<b>213JM</b>	2.84 (72)	22.39 (569)	2.84 (72)	23.06 (586)	2.84 (72)	22.39 (569)	2.84 (72)	23.00 (584)
<b>215JM</b>	2.84 (72)	23.52 (597)	2.84 (72)	24.19 (614)	2.84 (72)	23.52 (597)	2.84 (72)	24.13 (613)
<b>254JM</b>	3.84 (98)	25.65 (651)	3.84 (98)	26.32 (668)	3.84 (98)	25.65 (651)	3.84 (98)	26.26 (667)
<b>256JM</b>	3.84 (98)	27.41 (696)	3.84 (98)	28.08 (713)	3.84 (98)	27.41 (696)	3.84 (98)	28.02 (712)
<b>284JM</b>	3.84 (98)	31.01 (788)	3.84 (98)	31.68 (805)	3.84 (98)	31.01 (788)	3.84 (98)	31.62 (803)
<b>286JM</b>	3.84 (98)	31.22 (793)	3.84 (98)	31.89 (810)	3.84 (98)	31.22 (793)	3.84 (98)	31.83 (808)
<b>324JM</b>	3.84 (98)	33.11 (841)	3.84 (98)	33.78 (858)	3.84 (98)	33.11 (841)	-	-
<b>326JM</b>	3.84 (98)	33.11 (841)	3.84 (98)	33.78 (858)	3.84 (98)	33.11 (841)	-	-

**Table 4: Table of Dimensions for Figure 6**

<b>Model</b>	<b>Inlet inch (mm)</b>	<b>Outlet inch (mm)</b>	<b>X inch (mm)</b>	<b>Y inch (mm)</b>	<b>Z inch (mm)</b>	<b>MP inch (mm)</b>
<b>S2045</b>	1.5 (38)	1.5 (38)	3.88 (99)	2.56 (65)	1.99 (51)	4.08 (104)
	2.0 (51)	1.5 (40)	3.88 (99)	2.56 (65)	1.99 (51)	4.08 (104)
<b>S2065</b>	2.5 (64)	2.0 (51)	4.94 (125)	2.68 (68)	2.88 (73)	4.53 (115)
<b>S2065LV</b>	1.5 (38)	1.5 (38)	4.94 (125)	2.43 (62)	3.13 (79)	4.03 (102)
	2.0 (51)	1.5 (38)	4.94 (125)	2.43 (62)	3.13 (79)	4.03 (102)
	2.5 (64)	1.5 (38)	4.94 (125)	2.43 (62)	3.13 (79)	4.03 (102)
<b>S2065HV</b>	3.0 (76)	2.0 (51)	4.94 (125)	3.04 (77)	2.88 (73)	4.96 (126)
<b>S2075</b>	3.0 (76)	1.5 (40)	6.69 (170)	2.70 (69)	4.32 (110)	4.24 (108)
<b>S2085</b>	3.0 (76)	2.5 (64)	5.75 (146)	2.93 (74)	3.82 (97)	4.91 (125)
	4.0 (102)	2.5 (64)	5.75 (146)	2.93 (74)	3.82 (97)	4.91 (125)
<b>S2085LV</b>	2.0 (51)	1.5 (40)	6.69 (170)	2.70 (69)	4.32 (110)	4.24 (108)
<b>S2092</b>	3.0 (76)	2.0 (51)	6.64 (169)	3.09 (78)	4.62 (117)	4.85 (123)

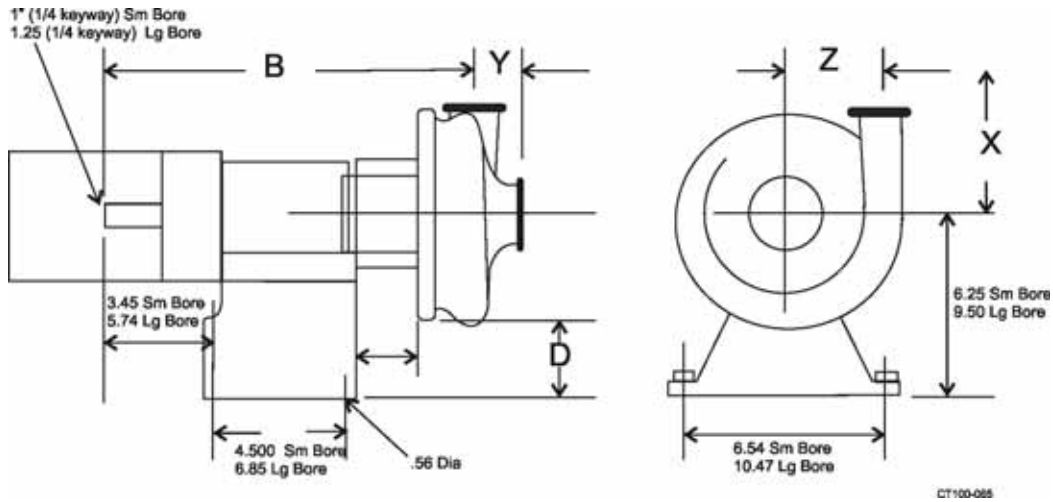


Figure 7 - Style "B" and "C" Less Base Plate

Table 5: Callout Table for Figure 7

Model	Inlet inch (mm)	Outlet inch (mm)	B		D	
			Sm Bore inch (mm)	Lg Bore inch (mm)	Sm Bore inch (mm)	Lg Bore inch (mm)
PS2045	1.5 (40)	1.5 (40)	15.0 (381)	---	2.7 (69)	---
	2.0 (50)	1.5 (40)	15.0 (381)	---	2.7 (69)	---
PS2065LV	1.5 (40)	1.5 (40)	14.9 (378)	18.6 (472)	1.7 (43)	4.9 (124)
	2.0 (50)	1.5 (40)	14.9 (378)	18.6 (472)	1.7 (43)	4.9 (124)
	2.5 (65)	1.5 (40)	14.9 (378)	18.6 (472)	1.7 (43)	4.9 (124)
PS2065	2.5 (65)	2.0 (50)	15.1 (384)	18.9 (480)	1.7 (43)	4.9 (124)
PS2065HV	3.0 (75)	2.0 (50)	15.2 (386)	18.9 (480)	1.7 (43)	4.9 (124)
PS2075	3.0 (75)	1.5 (40)	14.7 (373)	18.4 (472)	.6 (15)	3.9 (99)
PS2085LV	2.0 (50)	1.5 (40)	14.7 (373)	18.4 (472)	.6 (15)	3.9 (99)
PS2085	3.0 (75)	2.5 (65)	15.1 (384)	18.9 (480)	.6 (15)	3.9 (99)
	4.0 (100)	2.5 (65)	15.1 (384)	18.9 (480)	.6 (15)	3.9 (99)
PS2092	3.0 (75)	2.0 (50)	14.9 (378)	18.6 (472)	.6 (15)	3.9 (99)

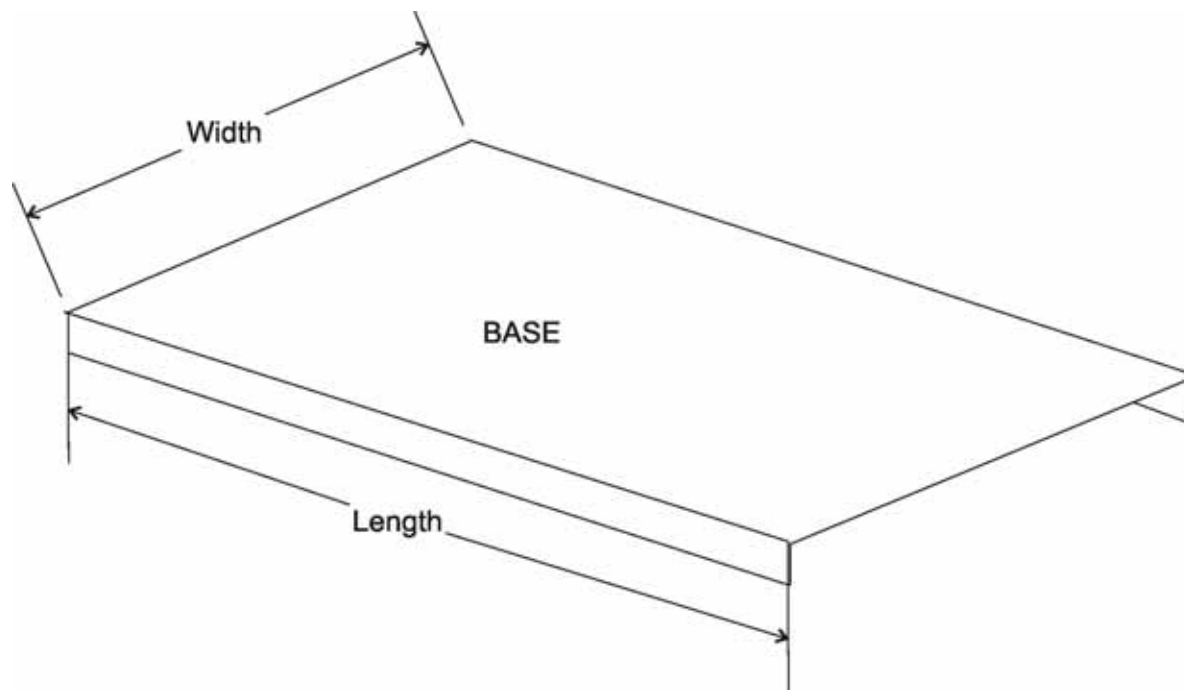
NOTE: Dimensions X,Y, B apply to pumps with clamp connections.

**Table 6: Table of Base Size Used On Pedestal Mounted Centrifugal Pumps**

MOTOR HP & RPM	SANITARY AND INDUSTRIAL MODELS						
	PS2045	PS2065LV	PS2065/ PS2065HV	PS2075	PS2085LV	PS2085	PS2092
Up to 5HP 1750 RPM	SM.B.	SM.B.	SM.B.	SM.B.	SM.B.	SM.B.	SM.B.
Up to 5HP 3500 RPM	SM.B.	SM.B.	SM.B.				
7½HP 1750 RPM						SM.B.	SM.B.
7½HP 3500 RPM		SM.B.	SM.B.	SM.B.	SM.B.	SM.B.	SM.B.
10HP 1750 RPM						SM.B.	SM.B.
10HP 3500 RPM		SM.B.	SM.B.	SM.B.	SM.B.	SM.B.	SM.B.
15HP 1750 RPM							
15HP 3500 RPM			SM.B.	SM.B.	SM.B.	SM.B.	SM.B.
20HP 1750 RPM							
20HP 3500 RPM			SM.B.	SM.B.	SM.B.	SM.B.	SM.B.
25HP 1750 RPM							
25HP 3500 RPM							
30HP 1750 RPM							
30HP 3500 RPM						L.G.B.	L.G.B.
40HP 1750 RPM							
40HP 3500 RPM						L.G.B.	L.G.B.
50HP 1750 RPM							
50HP 3500 RPM						L.G.B.	L.G.B.
60HP 3500 RPM						L.G.B.	L.G.B.
75HP 3500 RPM						L.G.B.	L.G.B.

SM.B. = Small Base

L.G.B. = Large Base



*Figure 8 - Base Channel Dimensions for Pedestal Mounted Centrifugal Pumps*

Baseplates are available in carbon steel channel base, carbon steel baseplate with feet or stainless steel baseplate with feet.

**Carbon Steel Channel Base**

10 x 26  
12 x 32  
15 x 32  
15 x 40  
16 x 41  
18 x 40  
18 x 50

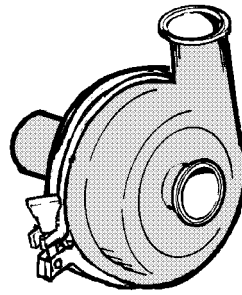
**Carbon Steel Baseplate**

12 x 26  
14.6 x 32  
17 x 41  
17 x 50

**Stainless Steel Baseplate**

12 x 32  
17 x 41  
17 x 50

**Centrifugal S200 Series Pump and Pedestal Weights**



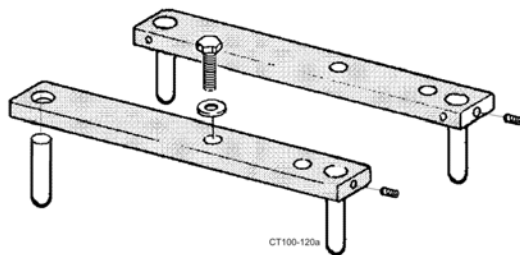
*Figure 9 - Close Coupled Pump*

**Table 7: Close Coupled Pump (Less Motor and Legs)**

MOTOR FRAME	PUMP MODEL							
	S2045 LBS (KG)	S2065LV LBS (KG)	S2065 LBS (KG)	S2065HV LBS (KG)	S2075 LBS (KG)	S2085LV LBS (KG)	S2085 LBS (KG)	S2092 LBS (KG)
143-184JM	21 (9.5)	31 (14)	33 (14.9)	39 (17.7)	57 (25.8)	57 (25.8)	51 (23.1)	51 (23.1)
213-215JM	35 (15.8)	37 (16.7)	39 (17.6)	64 (29)	54 (24.4)	54 (24.4)	78 (35.3)	78 (35.3)
254-256JM	37 (16.7)	39 (17.6)	41 (18.5)	67 (30.4)	57 (25.8)	57 (25.8)	79 (35.8)	79 (35.8)
284-326JM	51 (23.1)	53 (24)	71 (32.2)	68 (30.8)	82 (37.1)	82 (37.1)		

Add 5LB. For Pumps With Double Seals

**Table 8: Add Listed Weight for Legs**



*Figure 10 - Legs*

MOTOR FRAME	WEIGHT LBS (KG)
143-213JM	10.5 (4.7)
215-254JM	12.5 (5.6)
254-326JM	42.5 (19.2)

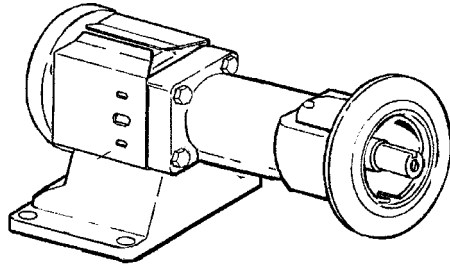


Figure 11 - Pedestal Pump (Less Base and Motor)

Table 9: Pedestal Pump (Less Base and Motor)

PUMP MODEL								
PEDESTAL	S2045 LBS (KG)	S2065LV LBS (KG)	S2065 LBS (KG)	S2065HV LBS (KG)	S2075 LBS (KG)	S2085LV LBS (KG)	S2085 LBS (KG)	S2092 LBS (KG)
SMALL BORE	92 (41)	106 (48)	108 (48.9)	114 (51.7)	131 (59.4)	131 (59.4)	125 (56.6)	125 (56.6)
LARGE BORE							235 (106.5)	235 (106.5)

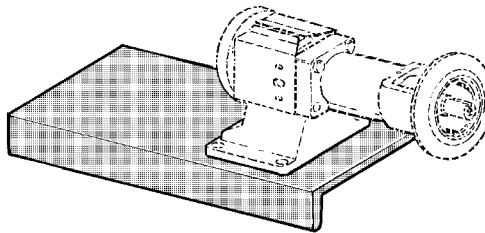


Figure 12 - Base Weight

Table 10: Channel Base Weight (Add to Pedestal Weight)

MOTOR	SMALL BORE LBS (KG)	LARGE BORE LBS (KG)
56	30 (13.6)	
143/145T	31 (14.6)	
182/184T	32 (14.5)	50 (22.6)
213/215T	33 (14.9)	50 (22.6)
254/256T	40 (18.1)	52 (23.5)
284/286T	35 (15.8)	62 (28.1)
284/286TS		64 (29.0)
324/326T		65 (29.4)
324/326TS		65 (29.4)
364TS		65 (29.4)

## Installation

Unpack all parts of your equipment and inspect for damages that may have occurred during shipping. Report any damage to the carrier.

All ports are covered at the factory to keep out foreign objects during transit. If the covers are missing or damaged, remove the pump cover and thoroughly inspect the fluid head. Be sure the pump head is clean and free of foreign material before rotating shaft.

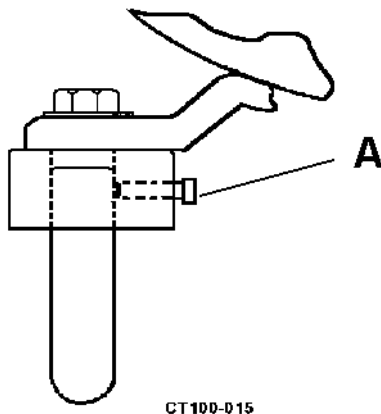
### Pump Location

The following considerations should be addressed when determining a location for the installation of your pump.

- Locate pump as near as practical to the liquid supply.
- Keep supply piping short and straight to keep pump supplied with liquid and prevent damaging cavitation.
- Pump should be accessible for service and inspection during operation.
- Motor must be protected from flooding.

### Pump Leveling

Level the pump by loosening the set screws (Figure 13, item A) to adjust the length of the legs.

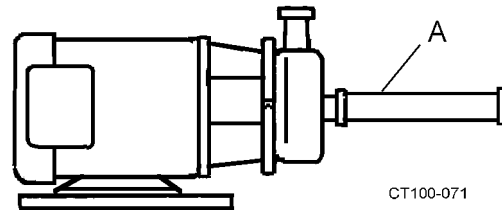


*Figure 13 - Leveling Leg Set Screw Location*

### Supply and Discharge Piping/Valves

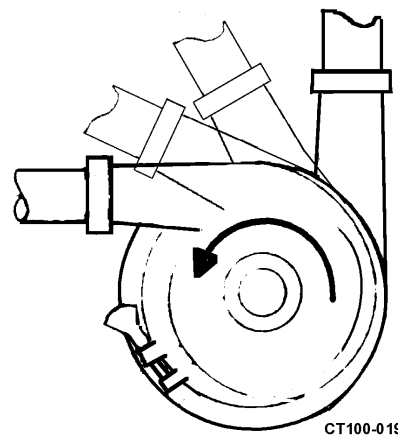
The following considerations should be addressed when determining supply/discharge piping and valve installation of your pump.

- Use line size equal to, or larger than, connection size on pump, especially the inlet supply line.
- Keep supply line as short and straight as possible and use as few elbows, valves or other types of restriction as possible. Avoid up and down rises which will trap air.
- Be certain all joints in the suction line are well sealed to prevent air leaks.
- Maintain a straight length of pipe (Figure 14, item A) at least 8 diameters long at the pump inlet.



*Figure 14 - Straight Pipe Length*

- The pump casing may be rotated with the discharge connection pointing in any direction. The best pump performance will be with the outlet up, to the left or positions in between; these positions insure a flooded casing and prevent problems due to air in the system. (Figure 14).



*Figure 15 - Recommended Discharge Positions*

- All joints in suction line must be well sealed to prevent air from being sucked into the system.
- Support supply and discharge piping near the pump so that no strain is put on the pump casing.

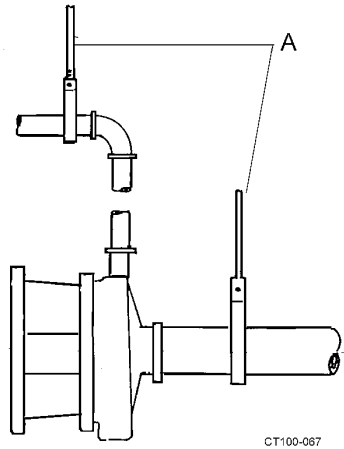


Figure 16 - Pipe Supports

- If an expansion joint is used, install a pipe anchor between the joint and the pump.
- If a reducer is connected to inlet, use eccentric type to prevent problems due to trapped air. (Figure 17)

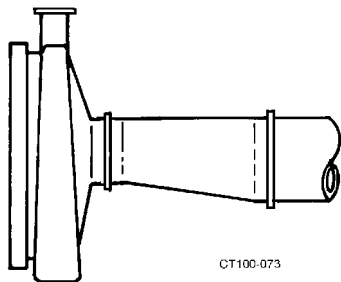


Figure 17 - Correct Eccentric Installation

**DANGER: caution**

The pump and piping may contain sharp edges. Wear gloves during installation and service of the pump to help avoid injuries from these hazards.

- Line slope will depend on application requirements; best pump operation is with supply line sloped slightly upward toward pump to prevent trapping air. If system must drain into pump casing, keep downward slope to a minimum or priming problems may occur.

- Install shutoff valves to isolate pump from supply and discharge lines. This will allow pump service without draining the system.
- This pump is not self priming. If pump is installed above supply liquid level, install foot valve or other system check valve to keep system flooded for priming. (Figure 18, item A).
- A throttling valve may be required to control pump flow rate to prevent motor overload. Always install throttling valve (Figure 18, item B) in discharge piping and at least 10 diameters from pump outlet.
- **Never** install throttling valve in supply piping. (Figure 18, item C).

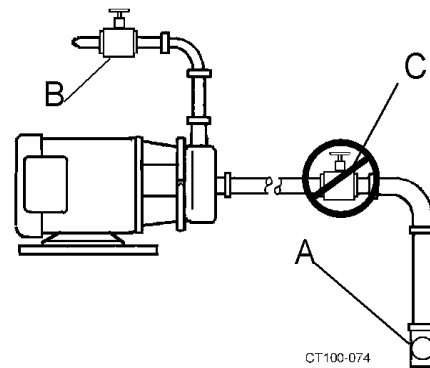


Figure 18 - Valve Piping Installation

**Installations That May Cause Operation Problems**

- Any system throttling valves or similar devices to control flow rate must be installed in the discharge line. **Do not** install any system throttling valves or similar devices to control flow rate in the supply line. Restriction in the supply line may cause cavitation and pump damage.
- "Water hammer" in the system can damage the pump and other system components. Water hammer often occurs when valves in the system are suddenly closed causing lines to move violently and with a loud noise. When this condition is present, find and eliminate the source of the water hammer. One way to eliminate water hammer is to slow down the actuation speed of the valve.
- Do not expose pump to freezing temperatures with liquid in casing. Frozen liquid in casing will damage pump. Drain casing before exposing to freezing temperatures.

## Electrical Connections

**DANGER: warning**

To avoid electrocution, ALL electrical installation should be done by a registered Electrician, following Industry Safety Standards. All power must be OFF and LOCKED OUT during installation.

- Read motor manufacturer's instructions before making installation. Follow manufacturer's lubrication schedules.
- Check motor nameplate to be sure motor is compatible with electrical supply and all wiring, switches, starters. Make sure all overload protections are correctly sized. (Figure 19).

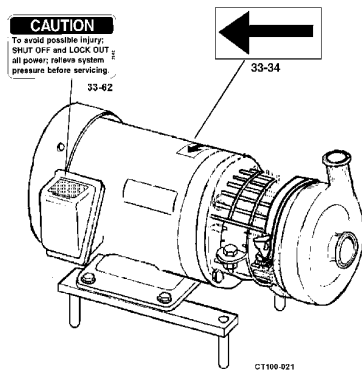


Figure 19 - Replaceable Label Location

- Check pump rotation following electrical installation. Correct rotation is counterclockwise when facing pump inlet connection. (Figure 15) and Figure 19.

## Flush Seal Option

When this option is ordered, a fitting assembly (Part Number 60112) (Figure 20, item B) is supplied for directing a flow of water onto the backplate/seal area.

- The water cascade block (Figure 20, item A) must be above the seal on the assembled backplate to flow water onto the seal face.
- The connection is 1/4 inch O.D. tubing.
- Required flow is approximately 5 U.S. gallons per hour.

- The recommended water supply is cool and filtered. If product solidifies at cool temperature, warm or hot water can be used.

**NOTE:** To prevent hose contact with rotating shaft and seal parts during operation, pull excess hose to outside of seal guard.

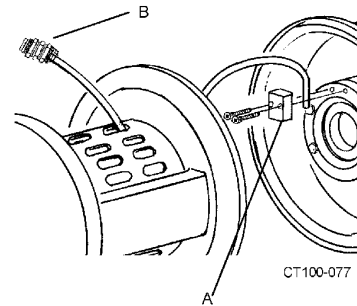


Figure 20 - Cascade System Installation

## Type 4 Seal

(Double mechanical with flush)

Attach seal flush supply to the bottom 1/4-inch pipe threaded hole in the flush housing. Drain tubing attached to the top hole allows moderate pressure to be supplied to the seals and continuous flooding. (Figure 21).

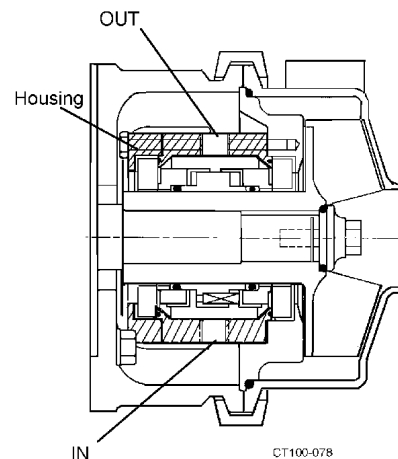


Figure 21 - Type 4 Flush Housing

## Before First Startup

### Clean Pump and Piping

Disassemble pump and clean all product contact parts and seal parts prior to first operation. Follow instructions in the "Cleaning Safety Procedures" on this page and "Routine Maintenance" on page 28. The pump should be thoroughly cleaned of any materials which could have accumulated during installation.

## Cleaning Safety Procedures

### **Manual Cleaning**

The following considerations should be addressed when manually cleaning your pump.

- Do not use toxic and/or flammable solvents.
- Lock out electrical power and shut off all air prior to cleaning equipment.
- Keep electrical panel covers closed and power off when washing equipment.

***DANGER: warning***

To prevent an accidental start-up the power source should be locked out using your lock and key.

- Clean up spills as soon as possible.
- Never attempt cleaning equipment while it is operating.
- Wear proper protective clothing.

### **Cleaning-In-Place (CIP)**

When performing CIP do the following:

1. Make certain that all connections in cleaning circuit are properly applied and tight to avoid contact with hot water or cleaning solutions.
2. When cleaning cycle is controlled from remote or automated cleaning center, establish safe procedures to avoid automatic start-up while servicing equipment in the circuit.

## Preliminary Test Run

The system should be tested using a preliminary run with the materials that will be pumped. **DO NOT** run the pump at this time to produce final product.

See “Starting the Pump” on page 27.

### **Check For Possible Motor Overload Conditions**

Certain combinations will overload motor when operated with open unrestricted discharge which results in too high flow rate. Additional discharge restriction may be required to lower flow rate and lower horsepower requirement. **DO NOT** add restriction to supply line. If pump was incorrectly selected, a smaller impeller may be required or a higher motor horsepower may be required.

If uncertain about pump selection and application, temporarily install an ammeter in the electrical service.

## Ammeter Test

***DANGER: warning***

To avoid electrocution and equipment damage, only a qualified electrician should install the ammeter.

Operate pump under process conditions and check motor amp draw versus nameplate full load rating. If amp draw exceeds motor rating, a system change or pump change is required.

If process conditions and/or liquid changes (higher viscosity, higher specific gravity) recheck motor amp draw.

## Operation

Before proceeding make sure your pump has been correctly installed as described in “Installation” on page 23.

### Starting the Pump

The following is the procedure for starting the pump.

1. If pump has the flush seal option, start flow of flush water (approximately 5 US gallons per hour recommended rate) before operating the pump.
2. Prime the pump by flooding the pump casing with liquid **BEFORE** starting pump to avoid damage to pump parts. See “Priming the Pump With the Feed Source Above Pump Level” on page 27 or “Priming the Pump With the Feed Source Below Pump Level” on page 27.
3. Start pump motor and check rotation of motor to make sure it’s the same as the arrow on the pump.
4. Check the pump to see that liquid is flowing and that all piping connections and seals are leak free.
5. Make sure that the pump is not operating against a closed discharge. Continued operation against a closed discharge will heat liquid in casing to boiling and lead to pump damage.
6. Slowly open discharge valve until desired flow is obtained. Observe pressure gauges and if pressure is not attained quickly, stop pump and prime again.

### Priming the Pump

#### **Priming the Pump With the Feed Source Above Pump Level**

1. Fill supply tank with liquid; open supply line valve (suction) (Figure 22, item B).
2. Vent any air trapped in supply line or casing by opening the discharge valve. (Figure 22, item A).
3. Start the pump.

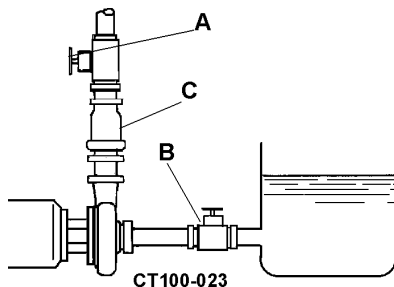


Figure 22 - Pump Below Supply

#### **Priming the Pump With the Feed Source Below Pump Level**

The pump will not self prime if liquid supply is below pump level. When liquid supply is below pump level an outside source must be provided for priming.

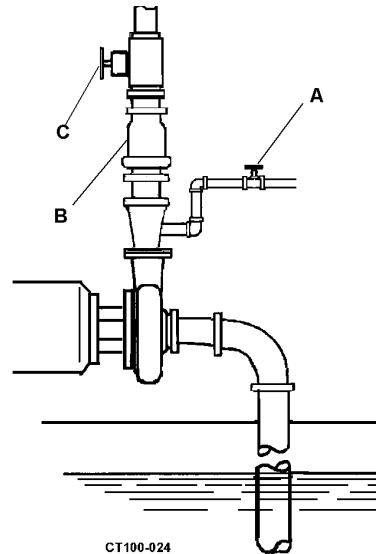


Figure 23 - Pump Above Supply

1. Close discharge valve (Figure 23, item C) and open air vents.
2. Open the valve installed in the outside supply line (Figure 23, item A) until liquid flows from vent valves.
3. Close vent valves.
4. Close outside supply line.

**NOTE:** Use a check valve system (Figure 23, item B) to keep supply line and pump casing flooded with liquid. Otherwise the pump must be primed before each operation.

### Stopping the Pump

1. To stop pump, shut off power to pump motor.

**NOTE:** Liquid in system can flow freely through the pump; the pump does not act as a shutoff valve.

2. Shut off supply and discharge lines.

**Maintenance**

**Scheduled Maintenance**

A routine maintenance program can extend the life of your pump. Make sure to keep maintenance records. These records will help pinpoint potential problems and causes.

**Routine Maintenance**

Your scheduled routine maintenance should include the following items:

- Check for unusual noise, vibration and bearing temperatures.
- Inspect pump and piping for leaks.
- Check Mechanical Seal area for leakage. No leakage is desired.
- Check backplate gasket for wear/damage.
- Bearing lubrication (See motor manufacturer for correct specifications).
- Seal Monitoring.
- Vibration analysis.
- Check discharge pressure.
- Temperature monitoring.

**Disassembly of Pump With a Type 1 Seal**

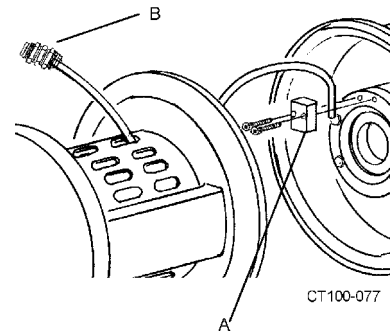
The following procedure covers the disassembly a of pump with a type 1 seal.

1. Shut off product flow to pump and relieve any product pressure.
2. Shut off and lockout power to pump.
3. Disconnect the suction and discharge pipe fittings.
4. Remove casing clamp and casing.
5. Slide O-ring off of backplate.
6. Remove impeller retainer bolt and shaft O-ring.

*NOTE: Retainer bolt has standard right hand threads.*

**Removal of the Water Cascade**

1. Loosen socket head screws holding water cascade block on the stationary seat retainer and remove plastic hose.



**Figure 24 - Removal of the Water Cascade System**

2. Pull off impeller/backplate assembly and place on a clean flat surface with impeller shaft up.

*NOTE: If assembly cannot be removed from motor shaft by hand contact Waukesha Cherry-Burrell Customer Service.*

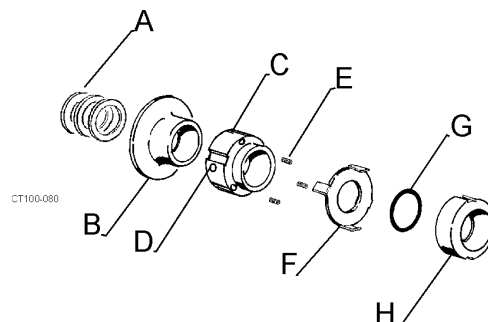
3. Locate shims on motor shaft and remove.

*NOTE: Motor shaft shims may fall off motor shaft or hang-up inside the deflector. Be sure to place all shims back on motor shaft.*

**DANGER: Caution**

Handle the impeller/backplate assembly with care to prevent damage to seal components.

4. Remove deflector. (Figure 25, item B).
5. Loosen set screws (2) (Figure 25, item D) in spring retainer (Figure 25, item C) and slide retainer and washer (Figure 25, item F) off shaft. Save springs (3) (Figure 25, item E).



**Figure 25 - Type 1 Seal Items**

- Use backplate to slide rotary seal up the impeller shaft approximately 1-1/2 inches. (Figure 26).



**Figure 26 - Moving the Rotary Seal up the Shaft**

- With the backplate resting on the impeller, push the rotary seal toward the backplate until the O-ring is free. (Figure 27).



**Figure 27 - Push Rotary Seal Down Until the O-ring is Released.**

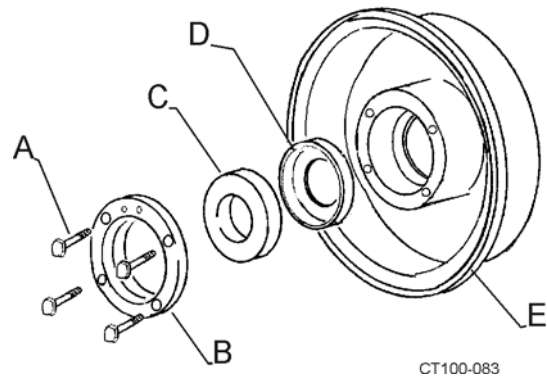
- Remove O-ring, then lift rotary seal off shaft. (Figure 25, items G and H).

**DANGER: Caution**

To avoid seal failure, DO NOT place fingers on the carbon seal face.

- Lift the backplate off the impeller.

- Remove four 1/4" hex bolts and stationary seat retainer ring. (Figure 28, items A and B).



**Figure 28 - Removing Stationary Seal**

- Pull the stationary seal and L-gasket out of backplate. (Figure 28, items C and D).

**NOTE:** The stationary seal is brittle. Prying or hammering on the seal plate can shatter the seal. If the stationary seal cannot be removed by hand, place a 2-1/4 inch diameter plastic or wood rod on the impeller side of the seal and apply even pressure to dislodge the seal.

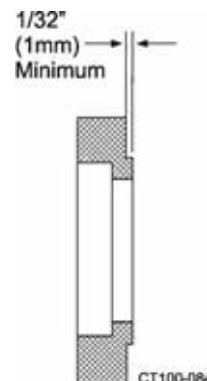
**Inspect Parts**

Once disassembly is complete perform the following inspections.

- Examine all seal surfaces and replace seals that become scratched, cracked and/or braised.
- Inspect all O-rings and O-ring seats for abrasions, cuts or other wear that could cause leakage.
- Clean all seat areas and alignment surfaces.

**NOTE:** Stationary seals are **reversible**. Use **both sides** before replacing.

**NOTE:** Replace the rotary seal when the seal face extends less than 1/32 inch (1mm) from the body (Figure 29)..

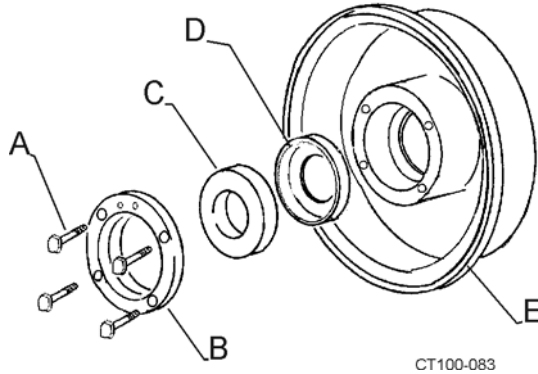


**Figure 29 - Replace Rotary Seal if Less Than Minimum**

**Assembly of Pump With a Type 1 Seal**

The following procedure covers the assembly of a pump with a Type 1 seal.

**Backplate Assembly**



**Figure 30 - Stationary Seal Assembly**

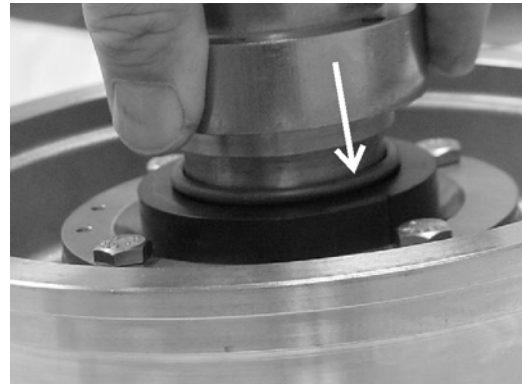
1. Lightly lubricate both sides of the L-gasket (Figure 30, item D) with a sanitary lubricant and insert into the backplate seal cavity.
2. Place the stationary seal into the L-gasket. (Figure 30, items C and D).
3. Place the seat retainer over the stationary seal and secure retainer with four 1/4-20 x 1/2 inch hex head cap screws. (Figure 30, items B and A).
4. Tighten the cap screws evenly.

**Backplate/Impeller Assembly**

1. Place impeller on a clean flat surface, shaft end up, and slide the assembled backplate onto the impeller shaft.

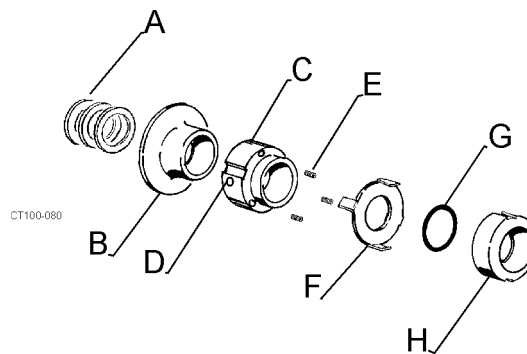
**NOTE:** Avoid hitting the stationary seal against the impeller shaft. It could break the seal.

2. Carefully place the rotary seal in position over the impeller shaft and down against the stationary seal.
3. Lubricate and slide the seal O-ring onto the impeller shaft. (Use the spring retainer as a tool to push the O-ring into the rotary seal). (Figure 42).



**Figure 31 - Installing O-ring Using the Spring Retainer.**

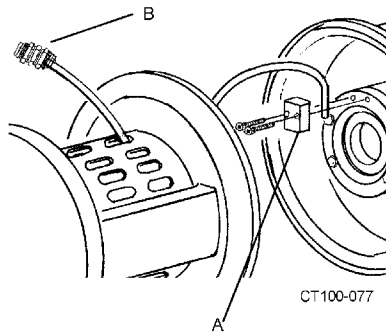
4. Slide the tabbed washer (Figure 30, item F) over the impeller shaft and engage the tabs of the washer into notches on the outside of rotary seal. (Figure 32, items F and H).



**Figure 32 - Type 1 Seal Assembly**

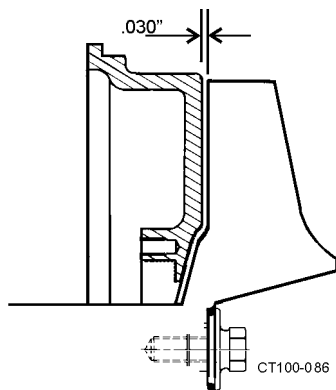
5. Install the three seal springs into holes in the spring retainer. (Figure 32, items C and E). Hold the springs in place with RTV silicone sealant.
6. Slide the spring retainer over the impeller shaft until the slots in the spring retainer engage the drive tabs on washer and springs rest against the washer. (Figure 32).
7. With the backplate against the impeller, push the spring retainer down to compress the springs until the length of visible spring is approximately 1/8".
8. Lock the spring retainer in place by tightening the set screws. (Figure 32, item D).
9. Install the deflector on to the impeller shaft. (Figure 32, item B).

- If your system has a water cascade, thread water cascade hose through the guard and install cascade block on backplate. (Figure 33, items A and B).

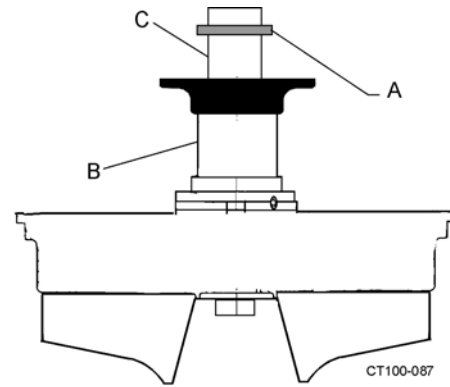


**Figure 33 - Installing the Water Cascade System**

- Slide the motor shims onto the shaft. The same number of shims that were removed when the pump was disassembled must be used.
- Install the impeller assembly on the stub shaft of the motor.
- Hand tighten the impeller retainer bolt on the shaft.
- Check the space between the back of the impeller and the backplate with a feeler gauge (.030 nominal) while holding the backplate tight against the bearing housing flange. (Any axial movement of the shaft should not be added to the .030 nominal clearance). (Figure 34). If needed, change this clearance by adding or removing shims. Shims (Figure 35, item A) are added on the drive shaft (Figure 35, item C) behind the impeller shaft (Figure 35, item B).



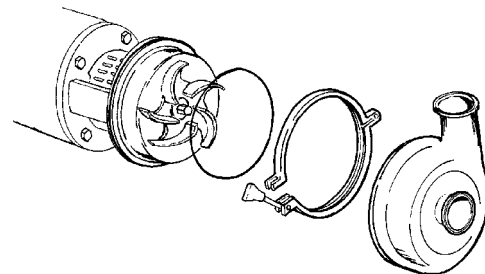
**Figure 34 - Clearance Between Impeller and Backplate**



**Figure 35 - Locations of Shims**

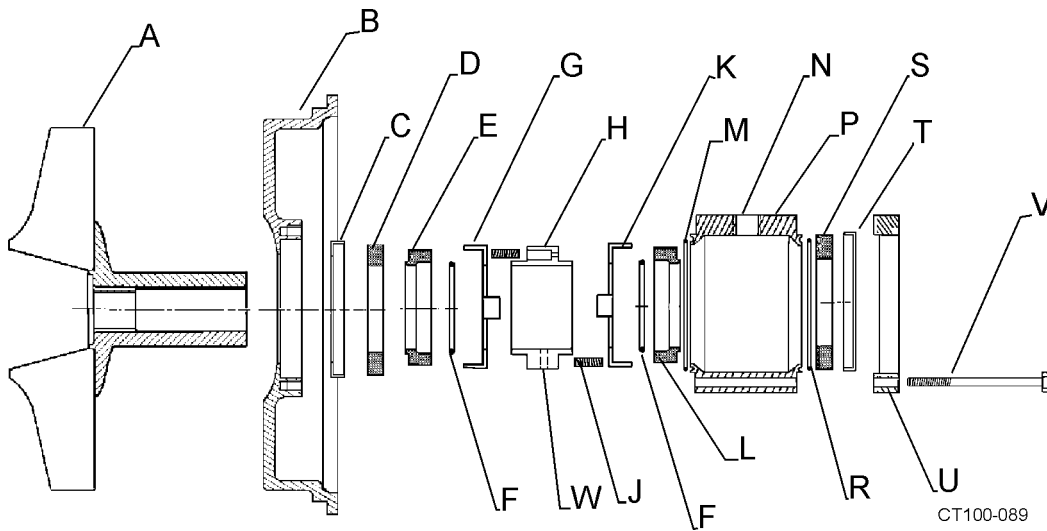
- Confirm operating clearances by clamping the casing to the bearing housing flange and rotating the shaft/impeller manually to be sure the impeller does not touch the casing or backplate.
- When proper shim pack is confirmed, remove backplate/impeller assembly leaving the shim pack on the shaft.
- Apply anti-sieze or equal compound to the motor shaft and install key.
- Install backplate/impeller assembly and lock in place using o-ring and impeller retainer nut. Wrench tighten.
- Install casing O-ring on backplate and clamp casing in place. (Figure 36).

**NOTE:** Rotate impeller manually to insure it does not rub on the backplate or casing.



**Figure 36 - Install Casing**

**Type 4 Double Seal**



*Figure 37 - Type 4 Seal Components*

**Table 11: Callouts for Figure 37**

A. Impeller	F. O-ring	L. Rotary Seal	S. Stationary Seal
B. Backplate	G. Washer	M. O-ring	T. L-gasket
C. L-gasket	H. Spring Retainer	N. NPT Port	U. Seat Retainer
D. Stationary Seal	J. Spring	P. Flush Housing	V. Hex Head Screw (4)
E. Rotary Seal	K. Washer	R. O-ring	W. Set Screw

The Type 4 Seal is essentially two Type 1 seals assembled back to back in a chamber which bolts to the backplate in place of the stationary seat retainer. Except for the additional components, (e.g. chamber, seals) Type 1 and Type 4 components are interchangeable. (Figure 37).

***DANGER: CAUTION***

Handle the impeller/backplate assembly with care to prevent damage to seal components.

## Disassembly Type 4 Seal

The following procedure covers the disassembly of a pump with a Type 4 seal.

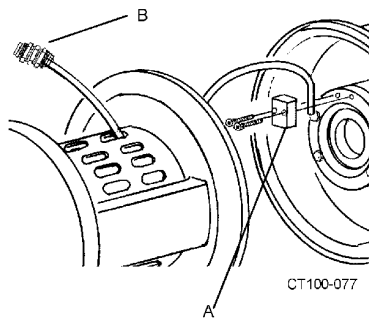
1. Shut off product flow to pump and relieve any product pressure.
2. Shut off and lockout power to pump.
3. Disconnect the suction and discharge pipe fittings.
4. Remove casing clamp and casing. Slide O-ring off of backplate.
5. Remove impeller retainer bolt and shaft O-ring.

**NOTE:** Retainer bolt has standard right hand threads.

### Removal of the Water Cascade

If your system is equipped with a water cascade system, it is necessary to remove it before proceeding.

1. Loosen socket head screws holding water cascade block on the stationary seat retainer and remove plastic hose.



**Figure 38 - Removal of the Water Cascade System**

2. Pull off impeller/backplate assembly and place on a clean flat surface with impeller shaft up.

**NOTE:** If assembly cannot be removed from motor shaft by hand contact Waukesha Cherry-Burrell Customer Service.

3. Locate shims on motor shaft and remove.

**NOTE:** Motor shaft shims may fall off motor shaft or hang-up inside the deflector. **Be sure to place all shims back on motor shaft.**

**DANGER: CAUTION**

Handle the impeller/backplate assembly with care to prevent damage to seal components.

4. Place impeller assembly **Face Down** (on impeller vanes) and remove hex head screws (Figure 37, item V) from back of seal assembly.

5. Carefully lift off seat retainer, O-ring, L-gasket, stationary seal and flush housing (Figure 37, items P, R, T, S and U).
6. Loosen (2) set screws in the spring retainer. (Figure 37, items W and H).
7. Lift off rotating seal components:
  - Rotary Seal (Figure 37, item L)
  - O-ring (Figure 37, item M)
  - Washer (Figure 37, item K)
  - Spring Retainer (Figure 37, item H)
  - Springs (six total, 3 up and 3 down) (Figure 37, item J)
  - Washer (Figure 37, item G)
8. Use backplate to slide rotary seal up the impeller shaft approximately 1-1/2 inches. (Figure 39).



**Figure 39 - Moving the Rotary Seal up the Shaft**

9. With the backplate resting on the impeller, push the rotary seal toward the backplate until the O-ring is free. (Figure 40).



**Figure 40 - Push Rotary Seal Down Until O-ring is Released.**

10. Remove stationary seal and L-gasket from backplate. (Figure 37, items D and C).

**NOTE:** The stationary seal is brittle. Prying or hammering on the seal plate can shatter the seal. If the stationary seal cannot be removed by hand, place a 2-1/4 inch diameter plastic or wood rod on the impeller side of the seal and apply even pressure to dislodge the seal.

11. Inspect and replace all damaged and worn parts.

Assembly of Type 4 Seal

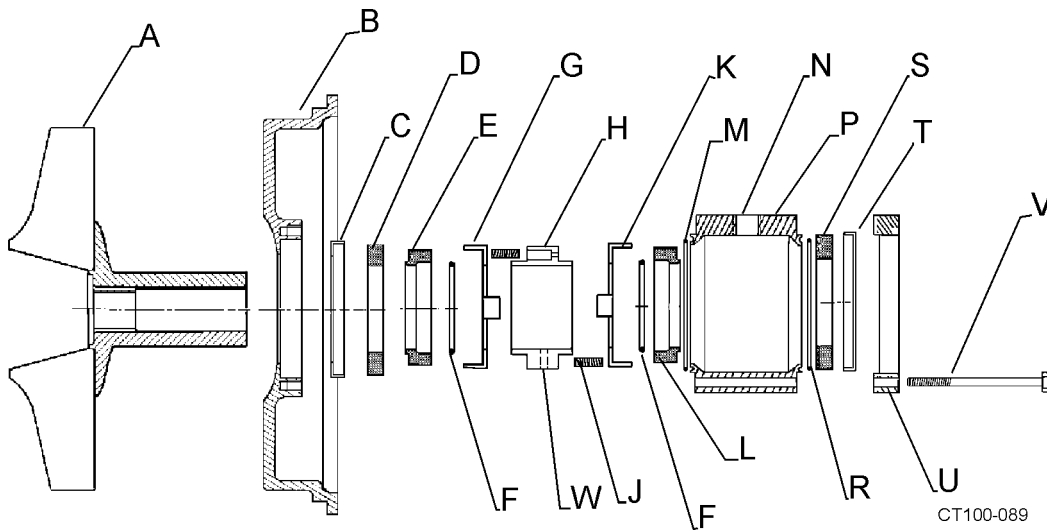


Figure 41 - Type 4 Seal Components

Table 12: Callouts for Figure 41

A. Impeller	F. O-ring	L. Rotary Seal	S. Stationary Seal
B. Backplate	G. Washer	M. O-ring	T. L-gasket
C. L-gasket	H. Spring Retainer	N. NPT Port	U. Seat Retainer
D. Stationary Seal	J. Spring	P. Flush Housing	V. Hex Head Screw (4)
E. Rotary Seal	K. Washer	R. O-ring	W. Set Screw

The following procedure covers the assembly of a pump with a Type 4 seal.

1. Clean all parts and lubricate all elastomer (Rubber-like) parts.

**DANGER: CAUTION**

Handle the impeller/backplate assembly with care to prevent damage to seal components.

2. Install L-gasket in backplate. (Figure 41, items B and C).
3. Install L-gasket in seat retainer. (Figure 41, item T).
4. Install stationary seals (Figure 41, item S) in L-gaskets.
5. Place backplate and rotary seal onto impeller shaft.
7. Place O-ring (Figure 41, item F) on shaft and use

6. Temporarily put 0.03" shims between the impeller vane and back plate to preset clearance. **Be sure to remove shims before final assembly.** (Figure 42).

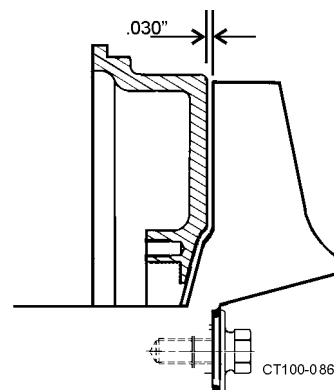
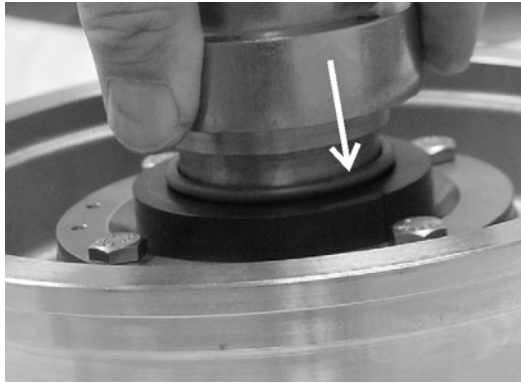


Figure 42 - Place Shims Between Impeller and Backplate

spring retainer to push O-ring into rotary seal. (Figure

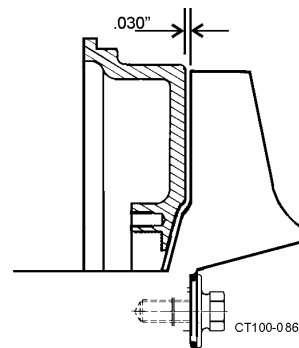


**Figure 43 - Installing the O-ring using the Spring Retainer.**

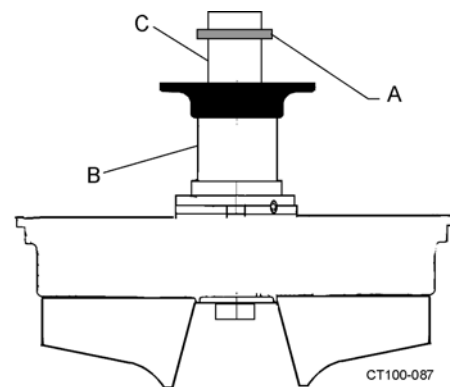
- 43).
8. Place washer (Figure 41, item G) over rotary seal with tabs in the outside diameter notches.
9. Place three springs (Figure 41, item J) in one side of spring retainer (hold them in place with silicone sealer) and slide the spring retainer (with the springs down) onto impeller shaft against washer.
10. Place the remaining three (3) springs in the spring retainer.
11. Slide the washer and O-ring (Figure 41, items K and F) onto the shaft against the spring retainer.
12. Use the spring retainer to press the O-ring into the rotary seal.
13. Remove 1/4 NPT plug from center port on flush housing. (Figure 41, item N).
14. Install an O-ring (Figure 41, items R and M) in both ends of housing.
15. Install L-gasket in seat retainer. (Figure 41, items T and U).
16. Install stationary seal (Figure 41, item S) in L-gasket.
17. Install housing over seal assembly.
18. With flush ports facing away from the backplate place seat retainer (Figure 41, item U) on housing.
19. Tighten seat retainer in place with four (4) hex screws (Figure 41, item V).

**NOTE:** Be sure to tighten screws evenly until full metal to metal contact is made on backplate and seat retainer.

20. Install original shims on the motor adaptor shaft.
21. Install backplate with seal assembly and impeller on motor shaft.
22. Check impeller/backplate clearance with the backplate held firmly in position against motor adaptor. Check the space between the back of the impeller and the backplate with a feeler gauge (.030 nominal) while holding the backplate tight against the bearing housing flange. (Any axial movement of the shaft should not be added to the .030 nominal clearance). (Figure 44). If needed, change this clearance by adding or removing shims. Shims (Figure 45, item A) are added on the drive shaft (Figure 45, item C) behind the impeller shaft (Figure 45, item B).



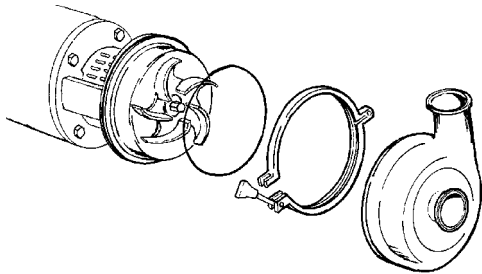
**Figure 44 - Clearance Between Impeller and Backplate**



**Figure 45 - Locations of Shims**

23. Confirm operating clearances by clamping the casing to the bearing housing flange and rotating the shaft/impeller manually to be sure the impeller does not touch the casing or backplate.

24. Tighten set screws in the spring retainer through 1/4 NPT center port in flush housing. (Figure 41, item N).
25. Insert plug in port and tighten.
26. Remove backplate/impeller assembly and apply anti-seize or equal compound to the motor shaft and install key.
27. Install backplate/impeller assembly and lock in place using O-ring and impeller retainer bolt.
28. Install casing O-ring on backplate and clamp casing in place. (Figure 46).

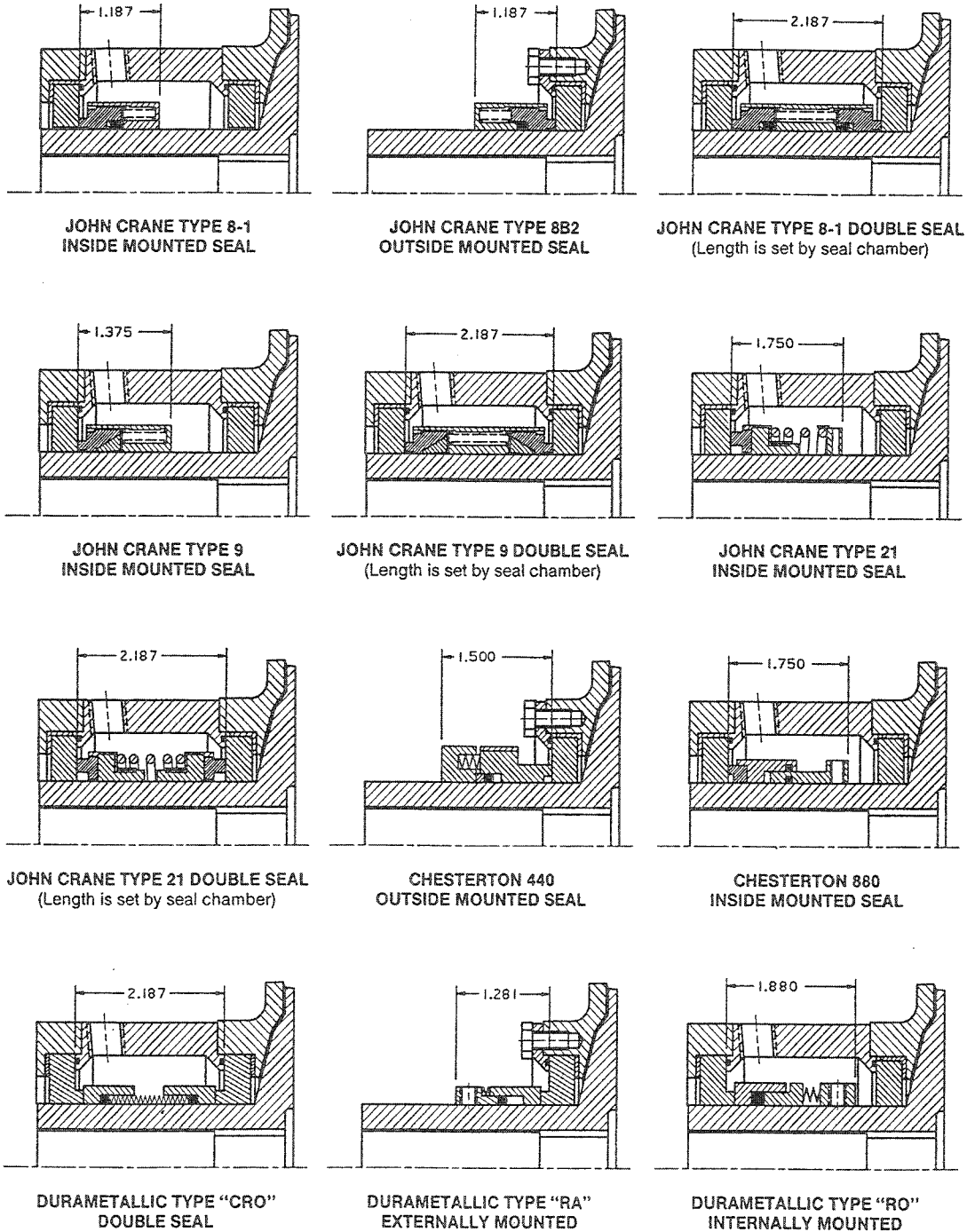


**Figure 46 - Install Casing**

**NOTE:** Rotate impeller manually to insure it does not rub on the backplate or casing.

**Standard Seal Dimensions**

The following seal assemblies are available with the 200 Series Pumps. These sketches provide the installed length dimension for each seal to facilitate assembly.

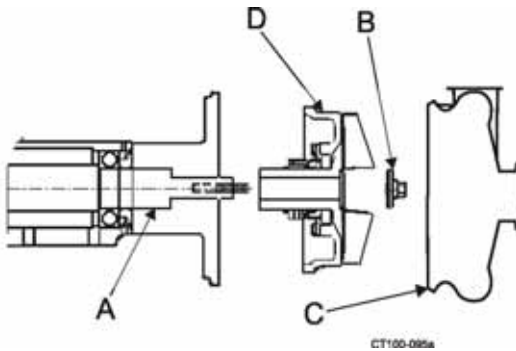


*Figure 47 - Installed Seal Length (For Aid of Assembly)*

**Disassembly of Modular Base Mounted Pumps**

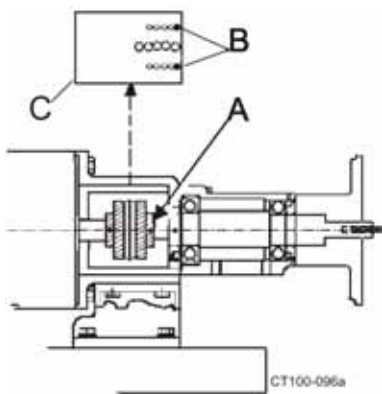
Refer to see “Disassembly of Pump With a Type 1 Seal” on page 28 and “Type 4 Double Seal” on page 32 for information on disassembling the pump seal items.

1. Shut off product flow to pump and relieve any product pressure.
2. Shut off and lockout power to pump.
3. Disconnect the suction and discharge pipe fittings.
4. Remove casing clamp and casing (Figure 48, item C). Slide O-ring off of backplate.



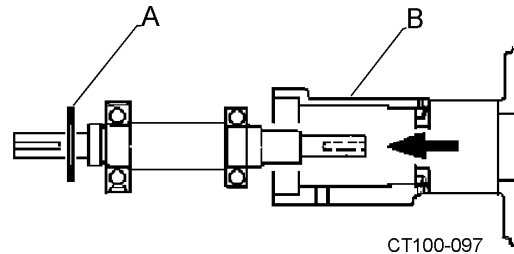
**Figure 48 - Removing the Impeller Assembly**

5. Remove impeller retainer nut and shaft O-ring (Figure 48, item B).
6. Pull impeller/backplate assembly off bearing housing shaft (Figure 48, items D and A).
7. Remove the coupling cover cap screws. (Figure 49, item B).



**Figure 49 - Removing Coupling Covers**

8. Loosen the set screws on the pump coupling. (Figure 49, item A).
9. **For Style B;** Remove bolts from adapter and stand. Remove housing and stand as a unit.
10. **For Style C;** Remove stand/housing assembly, than remove end cap. (Figure 53, item C on page 39).
11. Push the shaft and bearing assembly out of the housing from the impeller end. (Figure 50).



**Figure 50 - Bearing Shaft Assembly Removal**

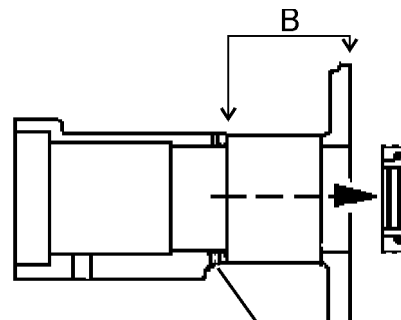
12. Remove the retaining ring and press the bearings off the shaft. (Figure 50, items A and B).

**Disassembling The Outer Seal Assemblies**

1. Using an 1/8" hex wrench, loosen set screws (Figure 51, item A).

*NOTE: The set screws are located opposite the grease fittings in the adapter or end cap.*

2. Remove the impeller end of the bearing housing. (Figure 51, item B).



**Figure 51 - Remove Set Screws**

3. Remove the outer seal ring assemblies (the inner seal ring and O-rings). (Figure 51) and Figure 52.

## Assembling the Outer Seal Assemblies

Reverse the above disassembly procedure with the added step of installing new O-rings in the seal rings.

**NOTE:** Figure 52 shows seal position at motor end. Seals at pump end face inward. Make sure to tighten set screws when installing outer seal assemblies. (Figure 53).

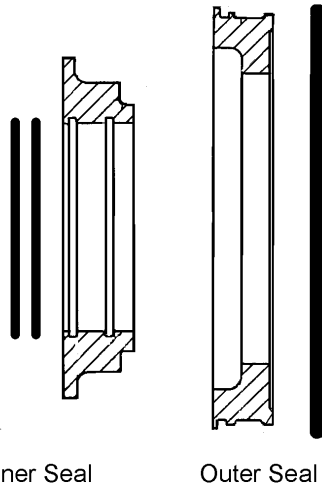


Figure 52 - Seal Configuration

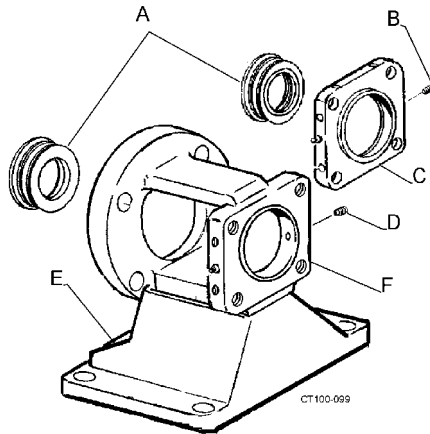


Figure 53 - Outer Seal Assemblies

Table 13: Call Outs for Figure 53

A. Outer Seal Assembly	D. Set Screw
B. Set Screw	E. Adaptor
C. End Cap	F. Stand

**NOTE:** It is recommended that all rubber parts be replaced whenever a unit is dismantled for inspection or repair. Lubricate rubber parts with an approved/sanitary lubricant prior to assembly.

## Pre-assembled (Cartridge) Seals

Pre-assembled (Cartridge) seals have all of the seal components mounted to a flange. They are pre-adjusted at the factory. Follow the seal manufacturer's (John Crane, A. W. Chesterton, etc.) recommendations regarding application, operation and maintenance.

**NOTE:** The cartridge seal comes with a set of removable lugs/spacers in place that are used to hold the assembly together until installation is final. Do not remove these lugs until installation is complete and you are told to do so in step 17 on page 42.

## Disassembly of Pre-assembled (Cartridge) Seals

The following procedure covers the disassembly of pre-assembled (cartridge) seals.

1. Remove all flush connections and fittings.
2. Remove the casing clamp, casing and O-ring from the housing flange. (Figure 54).

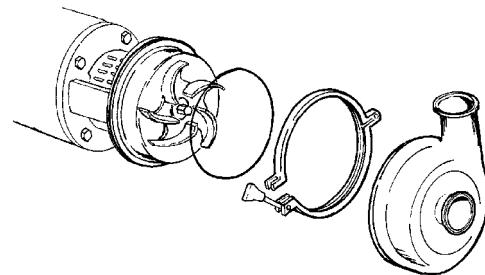


Figure 54 - Remove Casing Clamp, Casing and O-ring

3. Remove the impeller retainer nut and O-ring; then loosen the seal set screws. (Figure 55, item A).

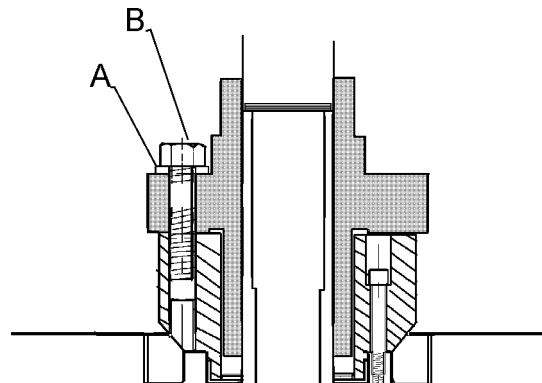
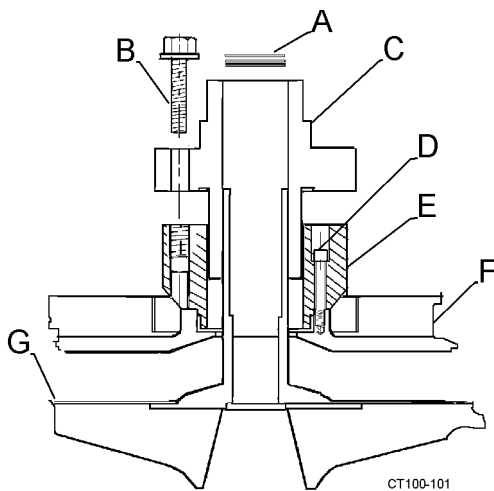


Figure 55 - Removal of Wet End

4. Pull the impeller, backplate and seal off the bearing shaft as a unit. Set the assembly face down (on the impeller).

**NOTE:** The clearance shims that position the impeller within the casing are at the end of the impeller hub (inside the seal.) Keep shims together as a set for reassembly. (Figure 56).

5. Remove cap screws (Figure 56, item B) holding the cartridge seal to the seal adapter. (Figure 56, items C and E).
6. Remove seal unit from the backplate assembly.
7. Pull seal from seal adapter. (Figure 56, items C and E).
8. Remove seal adapter by removing socket head cap screws (Figure 56, item D) holding adapter to the back plate.



**Figure 56 - Remove Seal Assembly.**

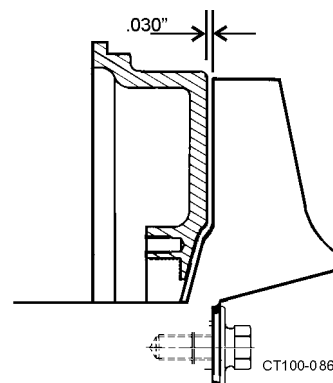
**Table 14: Callouts For Figure 56**

A. Shims	E. Adaptor
B. Cap Screw	F. Backplate
C. Cartridge Seal	G. Impeller
D. Socket Head Screw	

## Assembly of a Pump With Pre-assembled (Cartridge) Seals

The following procedure covers the disassembly of pre-assembled (cartridge) seals.

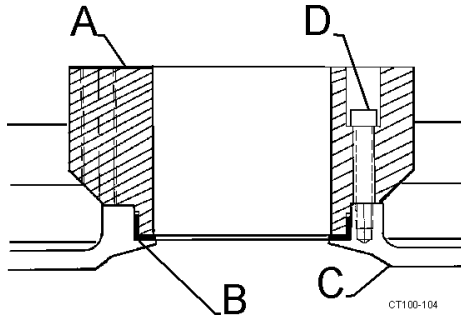
1. Place shims, backplate and impeller on the shaft assembly. Hand tighten the impeller retainer bolt on the shaft.
2. Check impeller/backplate clearance with the backplate held firmly in position against motor adapter. Check the space between the back of the impeller and the backplate with a feeler gauge (.030 nominal) while holding the backplate tight against the bearing housing flange. (Any axial movement of the shaft should not be added to the .030 nominal clearance). (Figure 57). If needed, change this clearance by adding or removing shims. Shims (Figure 56, item A) are added on the drive shaft behind the impeller shaft (Figure 56, item G).



**Figure 57 - Clearance Between Impeller and Backplate**

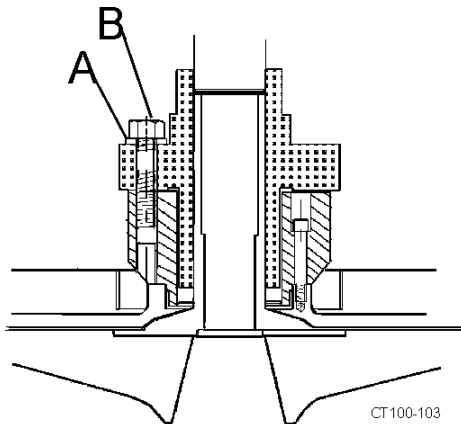
3. Confirm operating clearances by clamping the casing to the bearing housing flange and rotating the shaft/impeller manually to be sure the impeller does not touch the casing or backplate.
4. When proper shim pack is confirmed remove the casing, impeller and backplate leaving the shim pack on the shaft.
5. Insert L-gasket into the backplate. (Figure 58, items B and C).

6. Insert cartridge adapter (Figure 58, item A) into the backplate (Figure 58, item C) and tighten with four socket head cap screws.(Figure 58, item D).



**Figure 58 - Insert L-gasket and Fasten Adapter in Place**

7. Install the cartridge seal unit and use retaining bolts (Figure 59, item B) and flat washers (Figure 59, item A) to secure unit to the cartridge adapter. Make sure to not tighten the retaining bolts yet.



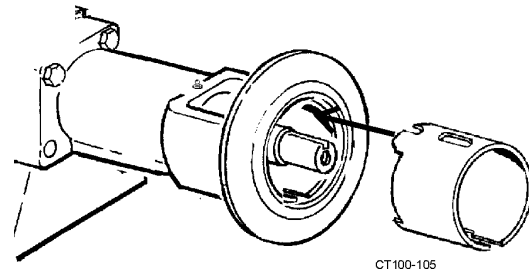
**Figure 59 - Fasten Seal Unit in Place**

**DANGER: Caution**

Be sure the removable lugs/spacers that position the rotating part of the seal in the housing are in place at this time.

8. Apply FDA approved anti-seize compound to the shaft.

9. Install and position the seal guard. (Figure 60).

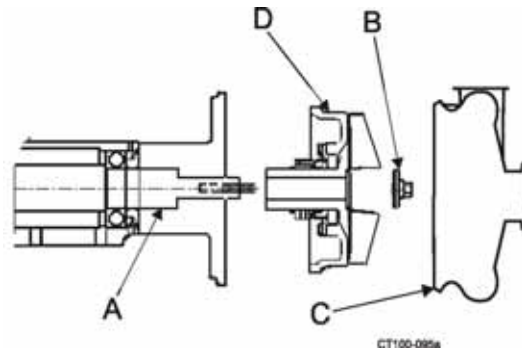


**Figure 60 - Installing the Guard**

10. Slide the impeller, backplate and seal unit onto the shaft.

**NOTE:** Be sure the flushing ports in the cartridge seal are positioned with the inlet toward the bottom and the outlet toward the top. (Figure 62, item C).

11. Install the impeller key. (Figure 61, item A).
12. Install the O-ring on the impeller retainer bolt. (Figure 61, item C).
13. Install impeller retainer nut and tighten. (Figure 61,



**Figure 61 - Installing Impeller Assembly**

item B).

14. Hold the backplate in place and tighten the cartridge seal into the cartridge adapter by tightening the cap screws (Figure 62, item E).

**NOTE:** The backplate and seal can be rotated to give access to the bolts through the holes in the guard.

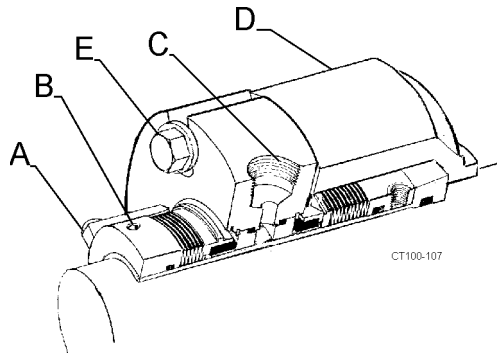


Figure 62 - Typical Cartridge Seal

Table 15: Call Outs For Figure 62

- A. Lugs/Spacers      D. Seal Adaptor
- B. Set Screw (2)    E. Cap Screws
- C. Flush Pots

15. Install O-ring and casing; clamp in place. (Figure 63).

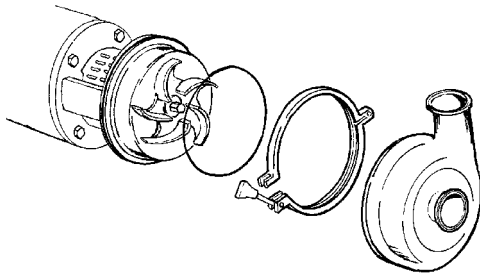


Figure 63 - Install O-ring, Casing And Clamp

- 16. Tighten the two set screws to the shaft. (Figure 62, item B).
- 17. Remove the lugs/spacers. (Figure 62, item A). **NOTE:** Keep lugs/spacers to reinstall on seal cartridge if removal is ever required.
- 18. Connect flushing fluid and flood seal.
- 19. Turn the shaft manually to be sure shaft rotates without the impeller hitting or binding.

**Pedestal Base Mounted Pump Housing Lubrication**

Waukesha Series S200 Pedestal Pumps are lubricated with GOA Micro-Plate 555 Lithium Complex Grease. Use only NLGI grade 2 Lithium Complex thickened greases to replenish bearing grease supply. Grease fittings indicated in Figure 64.

**NOTE:** Mixing greases that will not mix with the above products can change the viscosity/consistency of the grease resulting in bearing damage. If there is doubt remove the bearings, clean and re-pack.

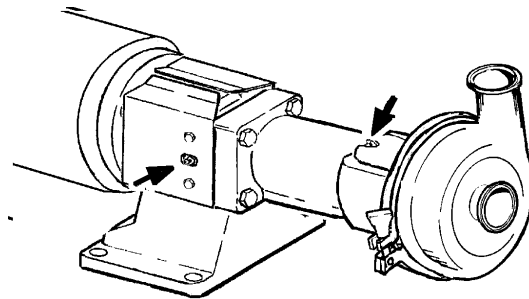


Figure 64 - Grease Fittings on the Pedestal Pump

For compatible lubricants contact Waukesha Application Engineering at

Telephone:

1-800-252-5200

Or 262-728-1900

**Lubrication Schedule**

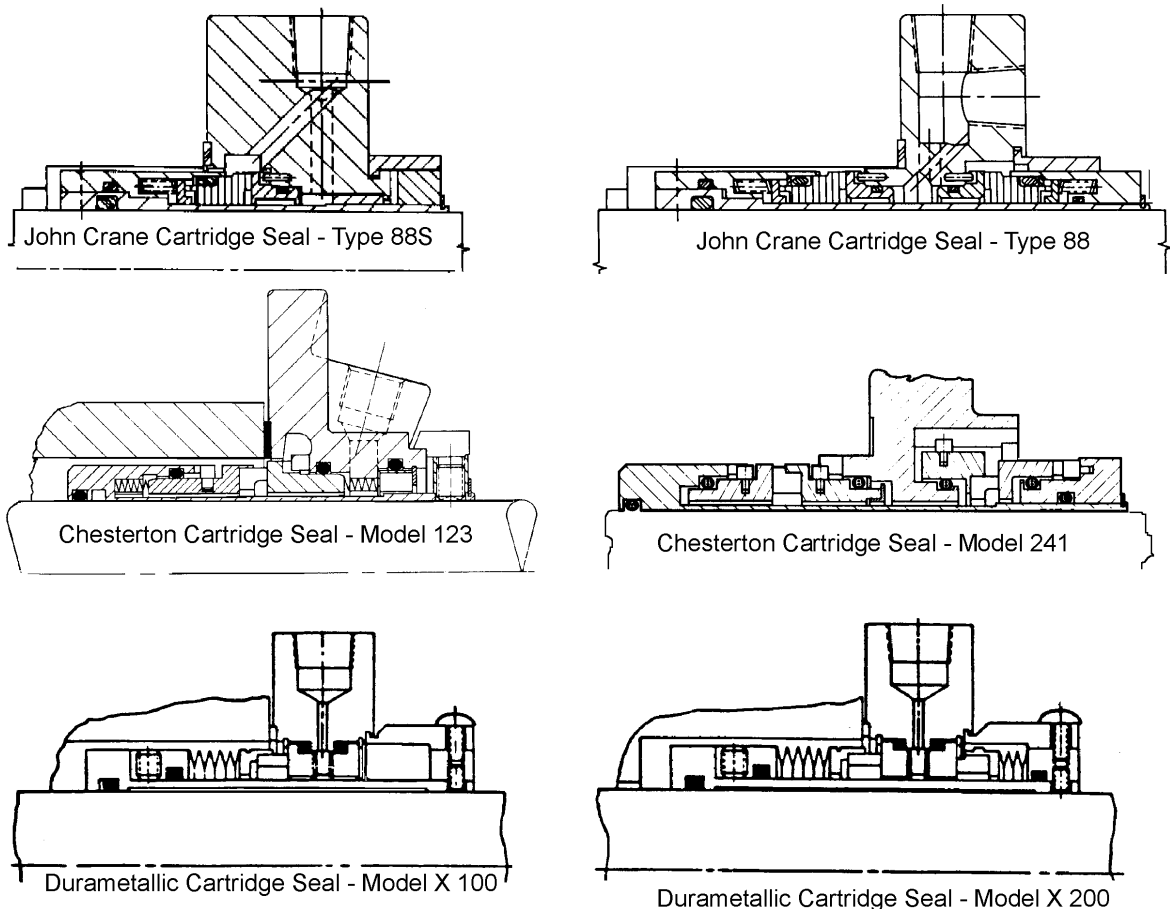
Table 16: Lubrication Schedule

Size/RPM	Hours
Small Bore/1750 RPM	4400
Small Bore/3500 RPM	2000
Large Bore/1750 RPM	2000
Large Bore/3500 RPM	1000

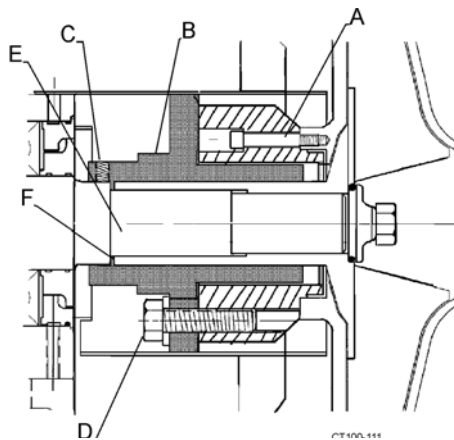
**NOTE:** If operating temperatures are over 158°F. (70°C.) reduce hours by half for every 27°F.(15°C.) over the operating temperature.

**Cartridge Seal**

The following pictorial list of cartridge seals is provided to assist in identifying some of the seals provided with the Model 200 centrifugal pumps. Use of these cartridges requires a cartridge seal adapter.



*Figure 65 - Installed Cartridge Seal*



*Figure 66 - Typical Cartridge Seal Installation*

**Table 17: Call Outs for Figure 66**

- |    |                         |
|----|-------------------------|
| A. | Socket Head Cap Screw   |
| B. | Cartridge Seal Assembly |
| C. | Set Screw (2)           |
| D. | Cap Screw               |
| E. | Bearing Shaft           |
| F. | Clearance Shims         |

## **Servicing the Electric Motor**

See the motors manufacturer's instructions for specific service information.

### **General Service Information**

Inspect units at regular intervals.

Keep units clean, and ventilation openings clear of dust, dirt or other debris.

Lubricate units per manufacturer's instructions and instruction plate on Unit.

***DANGER: CAUTION***

Do not over grease. Excessive lubrication may damage the unit.

***DANGER: WARNING***

Disconnect all power sources to the unit and discharge all parts which may retain an electrical charge before attempting any maintenance or repair. Screens and covers must be maintained in place when unit is in operation.

### **Motor Lubrication Instructions**

Some small motors have sealed for life bearings which require no lubrication.

Greasable bearings are shipped with a high quality wide temperature range grease in the bearings.

Some motors can be greased. Refer to the motor manufacturer's instructions for more information regarding lubrication procedures and additional service procedures.

## Parts Lists

## Seal Kits

## Basic Seal Kit - Type 1 Seal - Sanitary Pump Model

KIT CONTAINS	QTY	MODEL			
		S2045	S2065*	S2085*	S2092
CARBON SEAL (FKM & EPDM)	1	9-225A	9-225A	9-225A	9-225A
SEAL O-RING (FKM)	1	V70224	V70224	V70224	V70224
SEAL O-RING (EPDM)	1	E70224	E70224	E70224	E70224
CASING O-RING (FKM)	1	V70252	V70439	V70446	V70450
CASING O-RING (EPDM)	1	E70252	E70439	E70446	E70450
IMPELLER O-RING (FKM)	1	V70214	V70220	V70220	V70220
IMPELLER O-RING (EPDM)	1	E70214	E70220	E70220	E70220
KIT ORDER # (FKM)		<b>309-241</b>	<b>309-242</b>	<b>309-243</b>	<b>309-244</b>
KIT ORDER # (EPDM)		<b>309-241E</b>	<b>309-242E</b>	<b>309-243E</b>	<b>309-244E</b>

## Complete Seal Kit - Type 1 Seal - Sanitary Pump Model

KIT CONTAINS	QTY	MODEL			
		S2045	S2065*	S2085*	S2092
CARBON SEAL (FKM & EPDM)	1	9-225A	9-225A	9-225A	9-225A
SEAL O-RING (FKM)	1	V70224	V70224	9 10V	V70224
SEAL O-RING (EPDM)	1	E70224	E70224	E70224	E70224
CASING O-RING (FKM)	1	V70252	V70439	V70446	V70450
CASING O-RING (EPDM)	1	E70252	E70439	E70446	E70450
IMPELLER O-RING (FKM)	1	V70214	V70220	V70220	V70220
IMPELLER O-RING (EPDM)	1	E70214	E70220	E70220	E70220
STATIONARY SEAL (FKM & EPDM)	1	23-17	23-17	23-17	23-17
L - GASKET (FKM & EPDM)	1	9-37	9-37	9-37	9-37
KIT ORDER # (FKM)		<b>309-245</b>	<b>309-246</b>	<b>309-247</b>	<b>309-248</b>
KIT ORDER # (EPDM)		<b>309-245E</b>	<b>309-246E</b>	<b>309-247E</b>	<b>309-248E</b>

\*Includes LV and HV models

**Basic Seal Kit - Type 4 Seal - Sanitary Pump Model**

KIT CONTAINS	QTY	MODEL				
		S2045	S2065*	S2075	S2085*	S2092
CARBON SEAL (FKM & EPDM)	2	9-225A	9-225A	9-225A	9-225A	9-225A
SEAL O-RING (FKM)	2	V70224	V70224	V70224	V70224	V70224
SEAL O-RING (EPDM)	2	E70224	E70224	E70224	E70224	E70224
CASING O-RING (FKM)	1	V70252	V70439	V70446	V70446	V70450
CASING O-RING (EPDM)	1	E70252	E70439	E70446	E70446	E70450
IMPELLER O-RING (FKM)	1	V70214	V70220	V70220	V70220	V70220
IMPELLER O-RING (EPDM)	1	E70214	E70220	E70220	E70220	E70220
HOUSING O-RING (FKM)	2	V70039	V70039	V70039	V70039	V70039
HOUSING O-RING (EPDM)	2	E70039	E70039	E70039	E70039	E70039
KIT ORDER # (FKM)		<b>309-249</b>	<b>309-250</b>	<b>309-251</b>	<b>309-251</b>	<b>309-252</b>
KIT ORDER # (EPDM)		<b>309-249E</b>	<b>309-250E</b>	<b>309-251E</b>	<b>309-251E</b>	<b>309-252E</b>

**Complete Seal Kit - Type 4 Seal - Sanitary Pump Model**

KIT CONTAINS	QTY	MODEL				
		S2045	S2065*	S2075	S2085*	S2092
CARBON SEAL (FKM & EPDM)	2	9-225A	9-225A	9-225A	9-225A	9-225A
SEAL O-RING (FKM)	2	V70224	V70224	V70224	V70224	V70224
SEAL O-RING (EPDM)	2	E70224	E70224	E70224	E70224	E70224
CASING O-RING (FKM)	1	V70252	V70439	V70446	V70446	V70450
CASING O-RING (EPDM)	1	E70252	E70439	E70446	E70446	E70450
IMPELLER O-RING (FKM)	1	V70214	V70220	V70220	V70220	V70220
IMPELLER O-RING (EPDM)	1	E70214	E70220	E70220	E70220	E70220
HOUSING O-RING (FKM)	2	V70039	V70039	V70039	V70039	V70039
HOUSING O-RING (EPDM)	2	E70039	E70039	E70039	E70039	E70039
STATIONARY SEAL (FKM & EPDM)	2	23-17	23-17	23-17	23-17	23-17
L - GASKET (FKM & EPDM)	2	9-37	9-37	9-37	9-37	9-37
KIT ORDER # (FKM)		<b>309-253</b>	<b>309-254</b>	<b>309-255</b>	<b>309-255</b>	<b>309-256</b>
KIT ORDER # (EPDM)		<b>309-253E</b>	<b>309-254E</b>	<b>309-255E</b>	<b>309-255E</b>	<b>309-256E</b>

\*Includes LV and HV models

**Class VI Elastomer Kits**

MODEL	SINGLE		DOUBLE	
	FKM	EPDM	FKM	EPDM
<b>S2045</b>	118023	118069	118028	118074
<b>S2065</b>	118024	118070	118029	118075
<b>S2075</b>	118025	118071	118030	118076
<b>S2085</b>	118025	118071	118030	118076
<b>S2092</b>	118026	118072	118031	118077

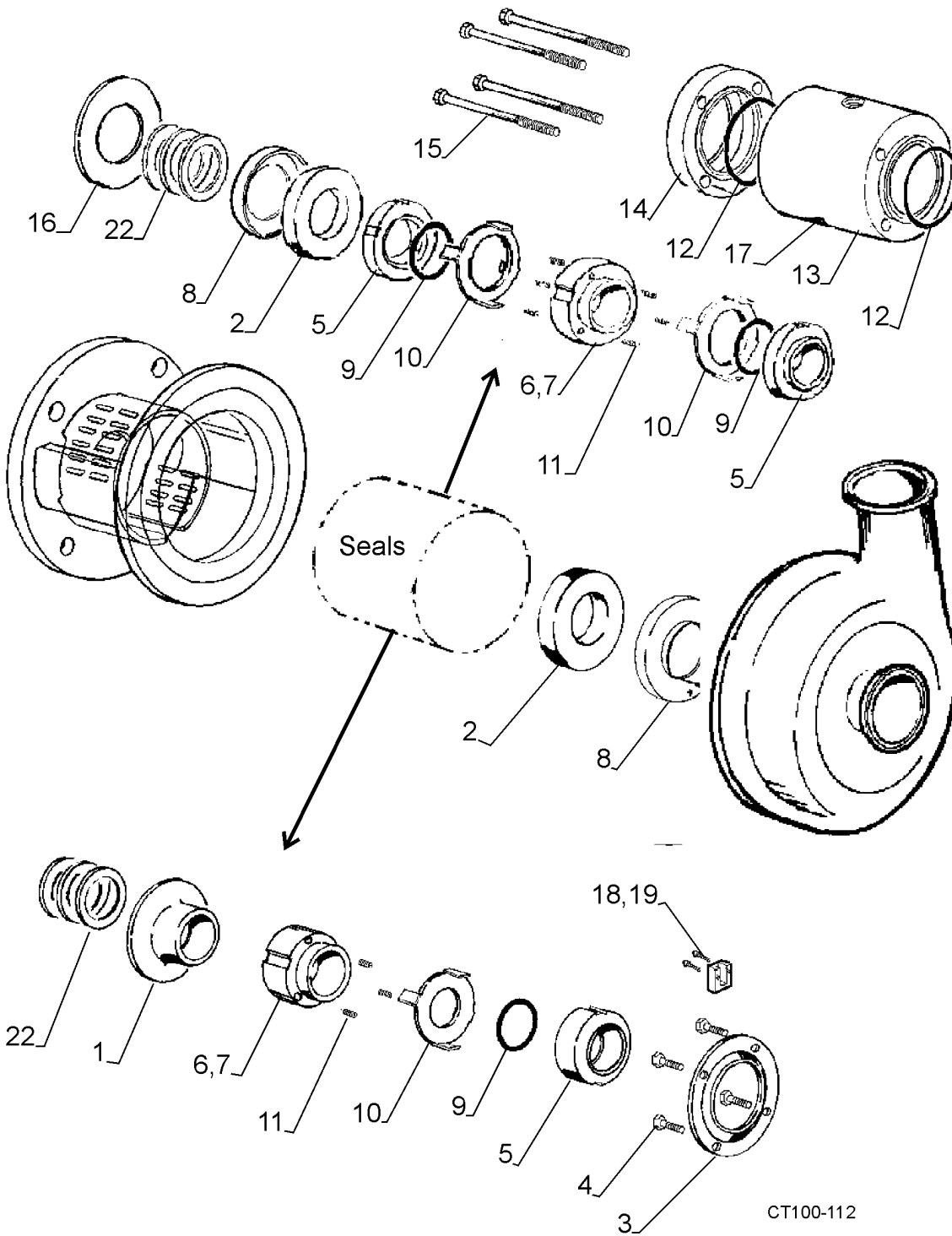
**\*\*Class VI Elastomers are only sold as kits\*\***

**Motor Shaft Shims**

**Table 18: Motor Shaft Shim**

MOTOR SHAFT SHIM	PART #	MOTOR NEMA FRAME SIZE	QTY
.005" THK.	35-4	254JM-326JM	AS REQUIRED
.010" THK.	35-5	254JM-326JM	AS REQUIRED
.020" THK.	35-6	254JM-326JM	AS REQUIRED
.005" THK.	35-1	143JM-215JM	AS REQUIRED
.010" THK.	35-2	143JM-215JM	AS REQUIRED
.020" THK.	35-3	143JM-215JM	AS REQUIRED

Seal Components All Pumps

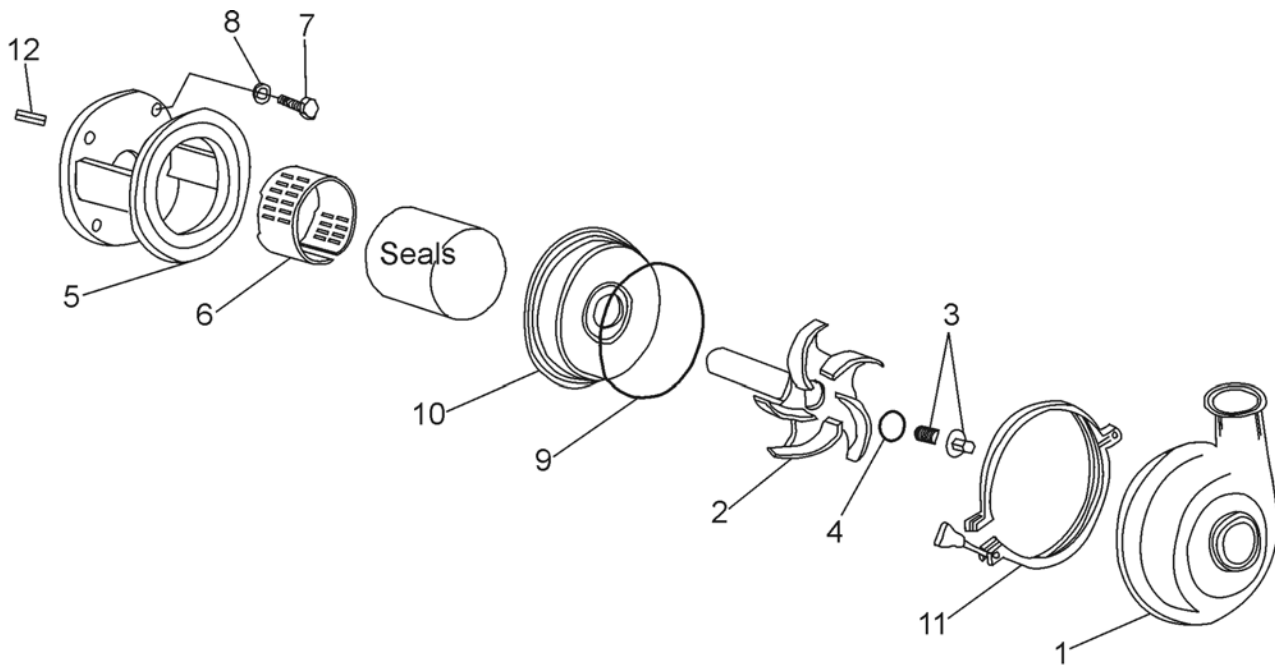


**Seal Components All Pumps**

ITEM #	DESCRIPTION	PART #	TYPE 1/1C SEAL QTY	TYPE 4 SEAL QTY
1	Deflector	69-1	1	-
* 2	Stationary Seal Purbide (1.75")	23-17	1	2
	Silicone Carbide (1.75")	23-17A	1	2
	Ceramic (1.75")	23-17E	1	2
	Tungsten Carbide (1.75")	23-17F	1	2
3	Seal Retainer	23-78	1	-
4	1/4 -20 x 1/2" Bolt (4 each)	30-62	4	-
* 5	Rotary Seal Carbon (1.75")	9-225A	1	2
	Purbide (1.75")	9-225B	1	2
	Silicone Carbide (1.75")	9-225C	1	2
	Tungsten Carbide (1.75")	9-225F	1	2
* 6	1/4-20 x 3/8" Set Screw (2 each)	30-178	2	1
* 7	Spring Retainer (1.75")	23-77	1	-
* 8	L-gasket FKM (1.75")	9-37	1	2
	EPDM (1.75")	9-37E	1	2
	FFKM (1.75")	9-37K	1	2
	Silicone	9-37R	1	2
* 9	O-ring FKM (1.75")	V70224	1	2
	EPDM (1.75")	E70224	1	2
	Chemrez® (1.75")	C75224	1	2
	FFKM (1.75")	K75224	1	2
	Silicone (1.75")	S75224	1	2
* 10	Washer, tabbed	43-87	1	2
* 11	Spring	24-65	3	6
* 12	O-ring, housing	V70039		2
13	Housing, seal	23-80		1
14	Retainer, seat	23-79		1
15	1/4-20 x 3" Cap Screw	30-175	4	4
16	Slinger, 142-215JM	69-4	-	1
17	1/4" N.P.T. Plug	78-155	-	1
18	Block, water cascade	134-2	1	
19	8-32 x 1/4" Socket Head	30-176	2	
20	1/4" Plastic Hose	74-1	9"	
21	1/4" Hose Fitting	78-18	1	

CT100-185

**S2045 Components (Close Coupled)**



CT100-113a

ITEM #	DESCRIPTION	20RA	15RA	15RA EP	20RA EP	
1	S2045 1515 Solid Bar Casing	S-Line	CENTPT00501	CENTPT00015	CENTPT00014	CENTPT00016
		Buttweld	CENTPT00502	CENTPT00018	CENTPT00017	CENTPT00019
		150# Flange	CENTPT00503	CENTPT00021	CENTPT00020	CENTPT00022
		DIN	CENTPT00504	CENTPT00024	CENTPT00023	CENTPT00025
	S2045 2015 Solid Bar Casing	S-Line	CENTPT00501	CENTPT00027	CENTPT00026	CENTPT00028
		Buttweld	CENTPT00502	CENTPT00030	CENTPT00029	CENTPT00031
		150# Flange	CENTPT00503	CENTPT00033	CENTPT00032	CENTPT00034
		DIN	CENTPT00504	CENTPT00036	CENTPT00035	CENTPT00037
2	S2045 Impellers	Small Bore	CENTPT00702	CENTPT00703	CENTPT00704	CENTPT00447
3	S2045 (129-773X) Retainer Nut	Small Bore (142/184)	CENTPT00705	CENTPT00706	CENTPT00707	CENTPT00708
10	Backplate		CENTPT00709	CENTPT00710	CENTPT00711	CENTPT00441

CT 100-186a

**S2045 Components (Close Coupled)**

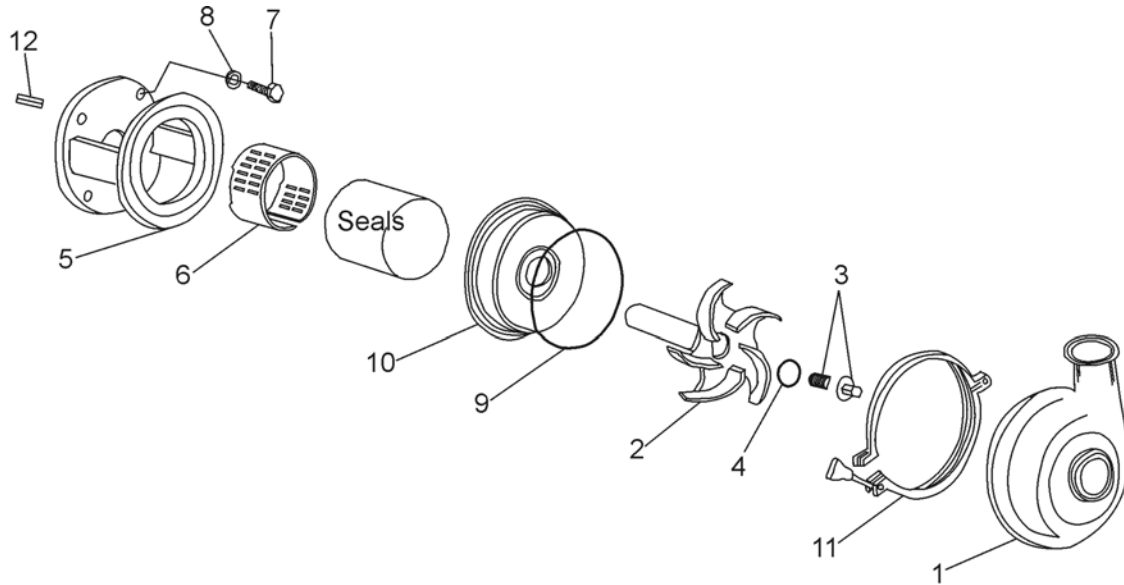
ITEM #	DESCRIPTION	PART #	QTY	
* 4	O-ring	FKM	V70214	1
		EPDM	E70214	1
		FFKM	T80214	1
5	Adapter, motor	2-235	1	
6	Seal guard (Type 1 Seal)	70-27	1	
7	3/8-16 x 3/4" Hex screw	30-30X	4	
8	3/8" Lock washer	43-28	4	
* 9	O-ring	FKM	V70252	1
		EPDM	E70252	1
		Silicone	S75252	1
		PTFE Encapsulated	T80252	1
		FFKM	K75252	1
11	Casing clamp	119-71	1	
12	Key 3/16" 184-215JM Motor Frame	65-3	1	

CT100-186

\*Recommended spare parts.

See "Seal Components All Pumps" on page 48 for metric seal kits.

**S2065/S2065LV/S2065HV Components (Close Coupled)**



CT100-113a

ITEM #	DESCRIPTION	20RA	15RA	15RA EP	20RA EP	
1	S2065LV 1515 Solid Bar Casing	S-Line	CENTPT00483	CENTPT00039	CENTPT00038	CENTPT00040
		Buttweld	CENTPT00509	CENTPT00042	CENTPT00041	CENTPT00043
		150# Flange	CENTPT00510	CENTPT00045	CENTPT00044	CENTPT00046
		DIN	CENTPT00511	CENTPT00048	CENTPT00047	CENTPT00049
	S2065LV 2015 Solid Bar Casing	S-Line	CENTPT00269	CENTPT00051	CENTPT00050	CENTPT00052
		Buttweld	CENTPT00512	CENTPT00054	CENTPT00053	CENTPT00055
		150# Flange	CENTPT00513	CENTPT00057	CENTPT00056	CENTPT00058
		DIN	CENTPT00514	CENTPT00060	CENTPT00059	CENTPT00061
	S2065LV 2515 Solid Bar Casing	S-Line	CENTPT00515	CENTPT00063	CENTPT00062	CENTPT00064
		Buttweld	CENTPT00516	CENTPT00066	CENTPT00065	CENTPT00067
		150# Flange	CENTPT00517	CENTPT00069	CENTPT00068	CENTPT00070
		DIN	CENTPT00518	CENTPT00072	CENTPT00071	CENTPT00073
	S2065 2520 Solid Bar Casing	S-Line	CENTPT00519	CENTPT00075	CENTPT00074	CENTPT00076
		Buttweld	CENTPT00520	CENTPT00078	CENTPT00077	CENTPT00079
		150# Flange	CENTPT00521	CENTPT00081	CENTPT00080	CENTPT00082
		DIN	CENTPT00522	CENTPT00084	CENTPT00083	CENTPT00085
	S2065HV 3020 Solid Bar Casing	S-Line	CENTPT00787	CENTPT00805	CENTPT00809	CENTPT00813
		Buttweld	CENTPT00790	CENTPT00806	CENTPT00810	CENTPT00814
		150# Flange	CENTPT00792	CENTPT00807	CENTPT00811	CENTPT00815
		DIN	CENTPT00788	CENTPT00808	CENTPT00812	CENTPT00816
2	S2065LV Impellers	Small Bore	CENTPT00393	CENTPT00304	CENTPT00299	CENTPT00403
		Large Bore	CENTPT00712	CENTPT00713	CENTPT00714	CENTPT00715
	S2065 Impellers	Small Bore	CENTPT00262	CENTPT00716	CENTPT00717	CENTPT00333
		Large Bore	CENTPT00718	CENTPT00719	CENTPT00720	CENTPT00334
	S2065HV Impellers	Small Bore	CENTPT00796	CENTPT00798	CENTPT00800	CENTPT00803
		Large Bore	CENTPT00797	CENTPT00799	CENTPT00801	CENTPT00804
3	Standard (129-771X) Retainer Nut					
	Small Bore (143/215)	CENTPT00538	CENTPT00539	CENTPT00540	CENTPT00541	
3	Standard (129-772X) Retainer Nut					
	Large Bore (324/365TC, 254/326JM)	CENTPT00543	CENTPT00544	CENTPT00542	CENTPT00451	
10	S2065LV/S2065/S2065HV Backplate	CENTPT00317	CENTPT00738	CENTPT00308	CENTPT00434	

CT100-187a

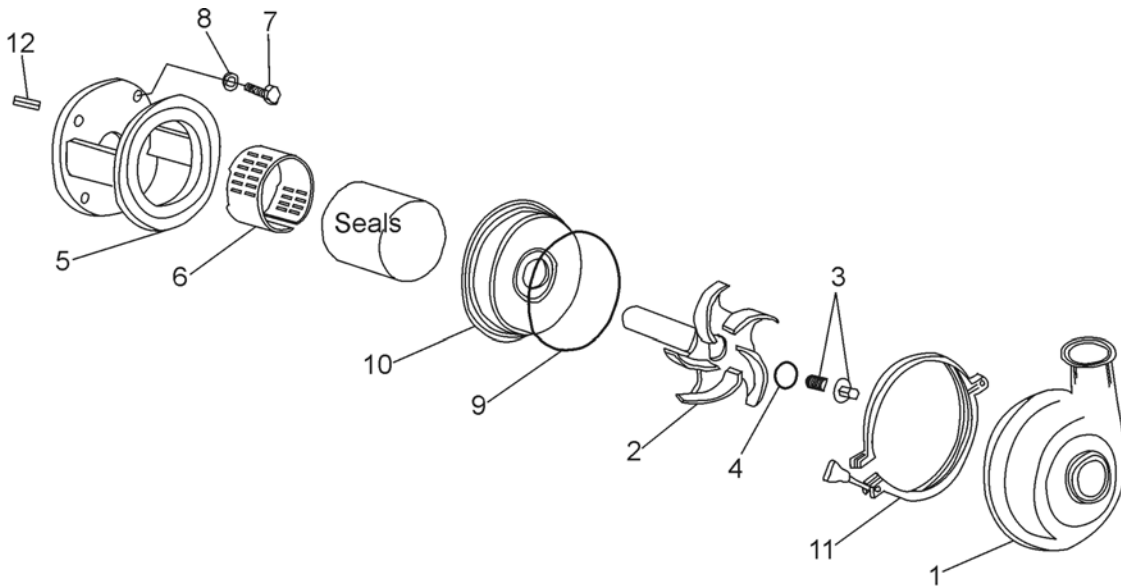
**S2065/S2065LV/S2065HV Components (Close Coupled)**

ITEM #	DESCRIPTION	PART #	QTY	
* 4	O-ring	FKM	V70220	1
		EPDM	E70220	1
		Silicone	S75220	1
		FFKM	K75220	1
5	Adapter	143-184JMMotor Frame	2-168	1
		213-215JMMotor Frame	2-169	1
		254-256JMMotor Frame	2-170	1
		284-326JMMotor Frame	2-196	1
6	Seal Guard (Type 1 Seal)	143-215 Motors	70-23	1
		254-256 Motors	70-24	1
		284-326 Motors	70-26	1
7	1/2-13 x 1-14" Bolt	213-256JMMotors	30-36X	4
	3/8-16 x 1" Bolt	143-184JMMotors	30-30X	4
	5/8-11 x 1-1/2" Bolt	284-286JMMotors	30-105	4
8	3/8" Lock washer		43-28	4
	1/2" Lock washer		43-16	4
	5/8" Lock washer		43-33	4
* 9	O-ring	FKM	V70439	1
		EPDM	E70439	1
		Silicone	S75439	1
		FFKM	K75439	1
11	Casing clamp		119-70	1
12	Key 3/16"	143-215JMMotor Frame	65-3	1
	Key 1/4"	254-326JMMotor Frame	65-4	1

CT100-187

\*Recommended spare parts.  
See "Seal Components All Pumps" on page 48 for metric seal kits.

**S2075 Components (Close Coupled)**



CT100-113a

ITEM #	DESCRIPTION		20RA	15RA	15RA EP	20RA EP
1	S2075 3015 Solid Bar Casing	S-Line	CENTPT00487	CENTPT00486	CENTPT00485	CENTPT00488
		Buttweld	CENTPT00687	CENTPT00688	CENTPT00689	CENTPT00690
		150# Flange	CENTPT00691	CENTPT00692	CENTPT00693	CENTPT00694
		DIN	CENTPT00695	CENTPT00696	CENTPT00697	CENTPT00698
2	S2075 Impellers	Small Bore	CENTPT00499	CENTPT00495	CENTPT00493	CENTPT00497
		Large Bore	CENTPT00500	CENTPT00496	CENTPT00494	CENTPT00498
3	S2075 (129-771X) Retainer Nut	Small Bore	CENTPT00538	CENTPT00539	CENTPT00540	CENTPT00541
		Large Bore	CENTPT00543	CENTPT00544	CENTPT00542	CENTPT00451
10	Backplate		CENTPT00492	CENTPT00490	CENTPT00489	CENTPT00491

CT 100-192

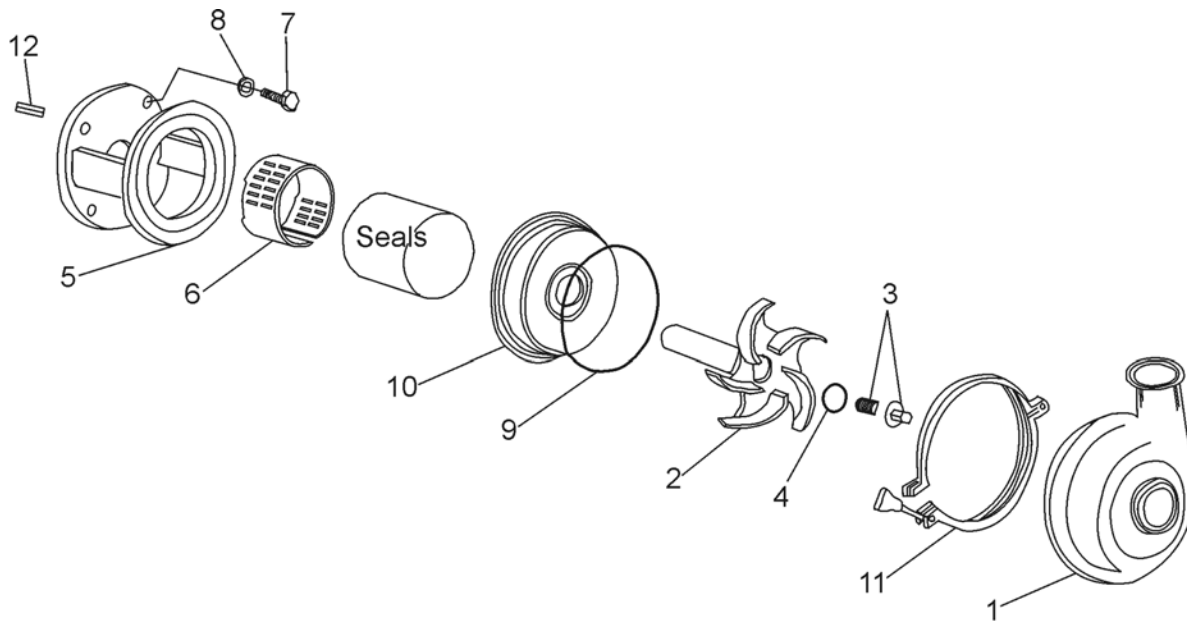
**S2075 Components (Close Coupled)**

ITEM #	DESCRIPTION	PART #	QTY		
* 4	O-ring	FKM	V70220	1	
		EPDM	E70220	1	
		Silicone	S75220	1	
		FFKM	K75220	1	
5	Adapter	143-184JM Motor Frame	2-171	1	
		213-215JM Motor Frame	2-172	1	
		254-256JM Motor Frame	2-173	1	
		284JM and Larger Motor Frame	2-174	1	
6	Seal Guard	143-215JM Motors	70-23	1	
		254-256 JM Motors	70-24	1	
		284-324JM Motors	70-26	1	
		284JM and Larger Motors	114508	1	
7	3/8-16 x 1" Bolt	143-184JM Motors	30-30	4	
		1/2-13 x 1 1/4" Bolt	213-256JM Motors	30-36X	4
		5/8-11 x 1-1/2" Bolt	284JM and Larger Motors	30-105	4
8	3/8" Lock washer		43-28	4	
		1/2" Lock washer	43-16	4	
		5/8" Lock washer	43-33	4	
* 9	O-ring	FKM	V70373	1	
		EPDM	E70373	1	
		Silicone	S75373	1	
		FFKM	K75373	1	
11	Casing clamp		119-69	1	
12	Key 3/16"	143-215JM Frame Motors	65-3	1	
		Key 1/4"	254-326JM Frame Motors	65-4	1

CT100-188

\*Recommended spare parts.  
See "Seal Components All Pumps" on page 57 for metric seal kits.

**S2085/2085LV Components (Close Coupled)**



CT100-113a

ITEM #	DESCRIPTION	20RA	15RA	15RA EP	20RA EP	
1	S2085LV 2015 Solid Bar Casing	S-Line	CENTPT00300	CENTPT00087	CENTPT00086	CENTPT00088
		Buttweld	CENTPT00523	CENTPT00090	CENTPT00089	CENTPT00091
		150# Flange	CENTPT00524	CENTPT00093	CENTPT00092	CENTPT00094
		DIN	CENTPT00525	CENTPT00096	CENTPT00095	CENTPT00097
	S2085 3025 Solid Bar Casing	S-Line	CENTPT00526	CENTPT00099	CENTPT00098	CENTPT00100
		Buttweld	CENTPT00527	CENTPT00102	CENTPT00101	CENTPT00103
		150# Flange	CENTPT00528	CENTPT00105	CENTPT00104	CENTPT00106
		DIN	CENTPT00529	CENTPT00108	CENTPT00107	CENTPT00109
	S2085 4025 Solid Bar Casing	S-Line	CENTPT00530	CENTPT00111	CENTPT00110	CENTPT00112
		Buttweld	CENTPT00531	CENTPT00114	CENTPT00113	CENTPT00115
		150# Flange	CENTPT00532	CENTPT00117	CENTPT00116	CENTPT00118
		DIN	CENTPT00533	CENTPT00120	CENTPT00119	CENTPT00121
2	S2085LV Impellers	Small Bore	CENTPT00728	CENTPT00306	CENTPT00302	CENTPT00729
		Large Bore	CENTPT00730	CENTPT00731	CENTPT00732	CENTPT00733
	S2085 Impellers	Small Bore	CENTPT00721	CENTPT00722	CENTPT00723	CENTPT00724
		Large Bore	CENTPT00725	CENTPT00726	CENTPT00727	CENTPT00448
3	Standard (129-771X) Retainer Nut					
	Small Bore (143/215)	CENTPT00538	CENTPT00539	CENTPT00540	CENTPT00541	
3	Standard (129-772X) Retainer Nut					
	Large Bore (324/365TC, 254/326JM)	CENTPT00543	CENTPT00544	CENTPT00542	CENTPT00451	
10	S2085LV/S2085 Backplate	CENTPT00739	CENTPT00740	CENTPT00741	CENTPT00430	

CT100-188a

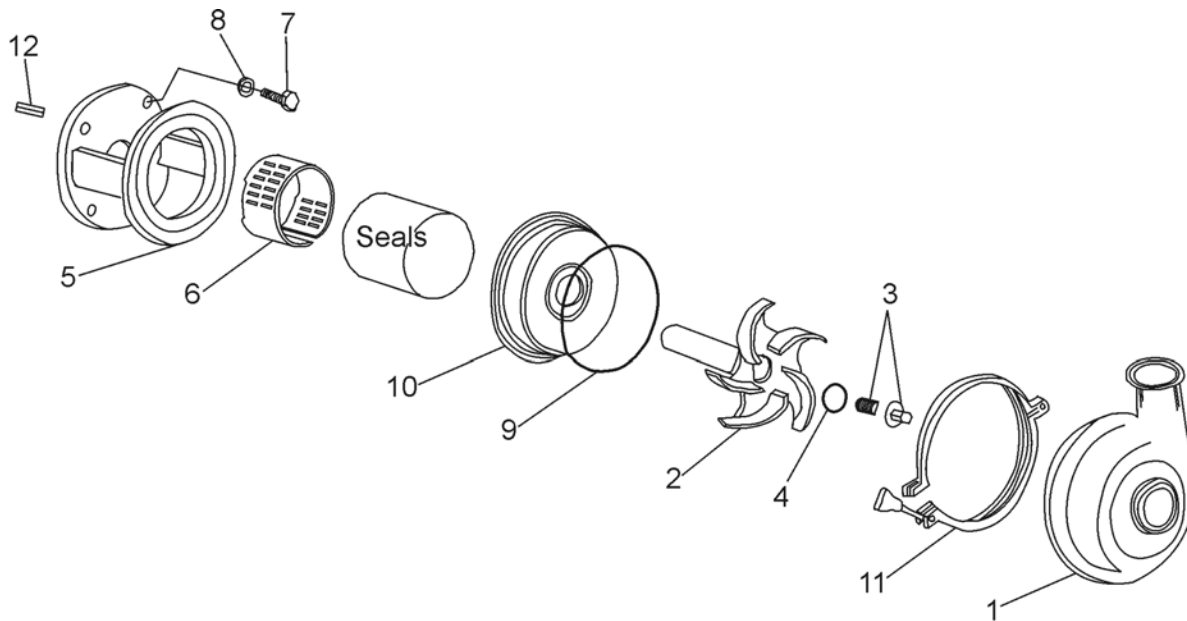
**S2085/2085LV Components (Close Coupled)**

ITEM #	DESCRIPTION	PART #	QTY		
* 4	O-ring	FKM	V70220	1	
		EPDM	E70220	1	
		Silicone	S75220	1	
		FFKM	K75220	1	
5	Adapter	143-184JM Motor Frame	2-171	1	
		213-215JM Motor Frame	2-172	1	
		254-256JM Motor Frame	2-173	1	
		284JM and Larger Motor Frame	2-174	1	
6	Seal Guard	143-215JM Motors	70-23	1	
		254-256 JM Motors	70-24	1	
		284-324JM Motors	70-26	1	
		284JM and Larger Motors	114508	1	
7	3/8-16 x 1" Bolt	143-184JM Motors	30-30	4	
		1/2-13 x 1 1/4" Bolt	213-256JM Motors	30-36X	4
		5/8-11 x 1-1/2" Bolt	284JM and Larger Motors	30-105	4
8	3/8" Lock washer		43-28	4	
		1/2" Lock washer	43-16	4	
		5/8" Lock washer	43-33	4	
* 9	O-ring	FKM	V70373	1	
		EPDM	E70373	1	
		Silicone	S75373	1	
		FFKM	K75373	1	
11	Casing clamp		119-69	1	
12	Key 3/16"	143-215JM Frame Motors	65-3	1	
	Key 1/4"	254-326JM Frame Motors	65-4	1	

CT100-188

\*Recommended spare parts.  
See "Seal Components All Pumps" on page 48 for metric seal kits.

**S2092 Components (Close Coupled)**



CT100-113a

ITEM #	DESCRIPTION	20RA	15RA	15RA EP	20RA EP
1	S2092 3020 Solid Bar Casing S-Line Buttweld 150# Flange DIN	CENTPT00534	CENTPT00123	CENTPT00122	CENTPT00124
		CENTPT00535	CENTPT00126	CENTPT00125	CENTPT00127
		CENTPT00536	CENTPT00129	CENTPT00128	CENTPT00130
		CENTPT00537	CENTPT00132	CENTPT00131	CENTPT00133
2	S2092 Impellers Small Bore Large Bore	CENTPT00734	CENTPT00735	CENTPT00736	CENTPT00737
		CENTPT00353	CENTPT00699	CENTPT00700	CENTPT00701
3	Standard (129-771X) Retainer Nut (Kit) Small Bore (143/215) Standard (129-772X) Retainer Nut (Kit) Large Bore (324/365TC, 254/326JM)	CENTPT00538	CENTPT00539	CENTPT00540	CENTPT00541
		CENTPT00543	CENTPT00544	CENTPT00542	CENTPT00451
10	S2092 Backplate	CENTPT00742	CENTPT00743	CENTPT00744	CENTPT00745

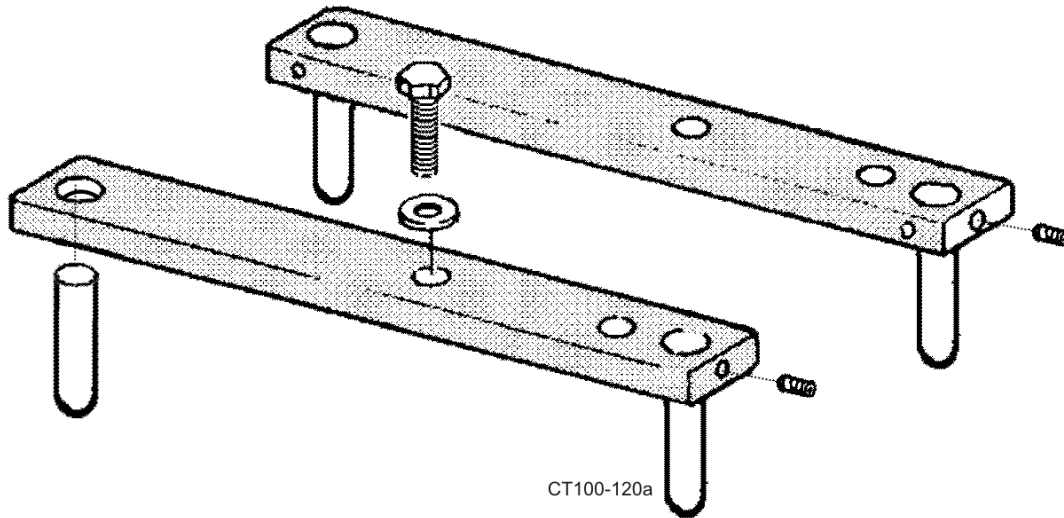
**S2092 Components (Close Coupled)**

ITEM #	DESCRIPTION	PART #	QTY	
* 4	O-ring	FKM	V70220	1
		EPDM	E70220	1
		Silicone	S75220	1
		FFKM	K75220	1
5	Adapter	143-184JM Motor Frame	2-171	1
		213-215JM Motor Frame	2-172	1
		254-256JM Motor Frame	2-173	1
		284JM and Larger Motor Frame	2-174	1
6	Seal Guard	143-215JM Motors	70-23	1
		254-256 JM Motors	70-24	1
		284-324JM Motors	70-26	1
		284JM and Larger Motors	114508	1
7	3/8-16 x 1" Bolt	143-184JM Motors	30-30	4
		213-256JM Motors	30-36X	4
		284JM and Larger Motors	30-105	4
8	3/8" Lock washer		43-28	4
		1/2" Lock washer	43-16	4
		5/8" Lock washer	43-33	4
* 9	O-ring	FKM	V70373	1
		EPDM	E70373	1
		Silicone	S75373	1
		FFKM	K75373	1
11	Casing clamp		119-69	1
12	Key 3/16"	143-215JM Frame Motors	65-3	1
		254-326JM Frame Motors	65-4	1

CT100-188

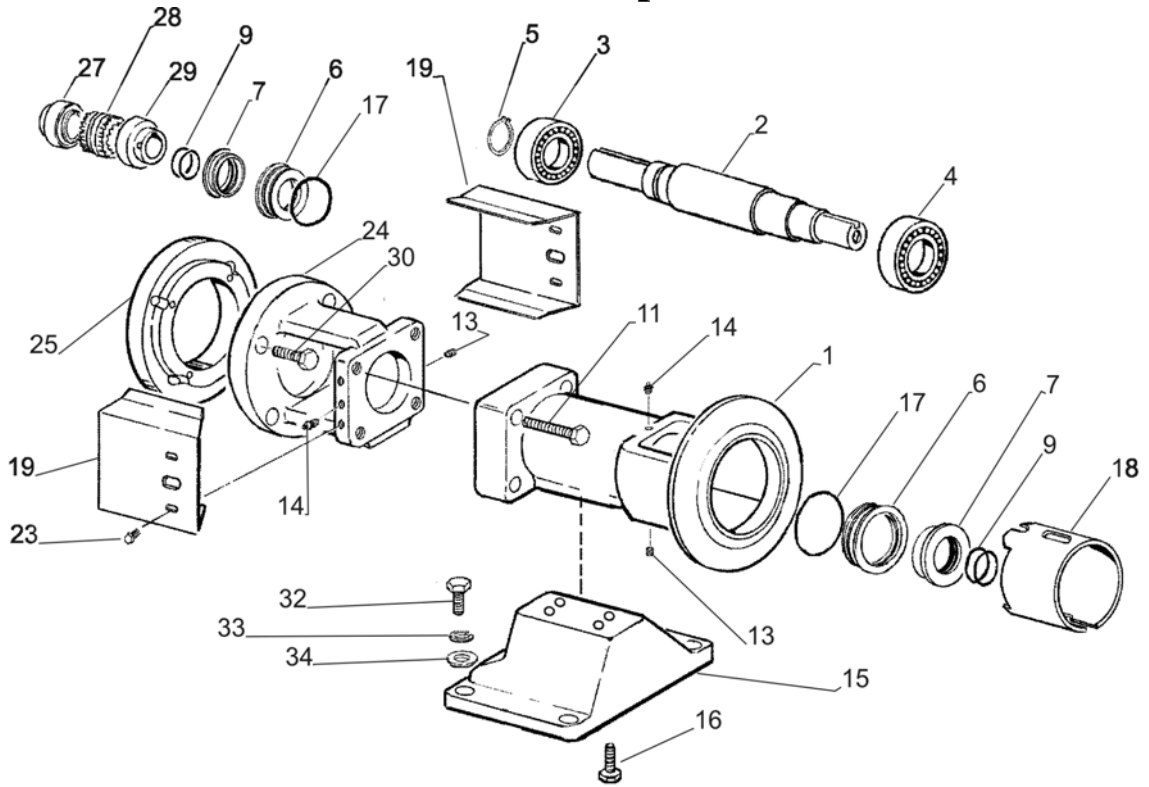
\*Recommended spare parts.  
See "Seal Components All Pumps" on page 48 for metric seal kits.

**Motor Mounts**

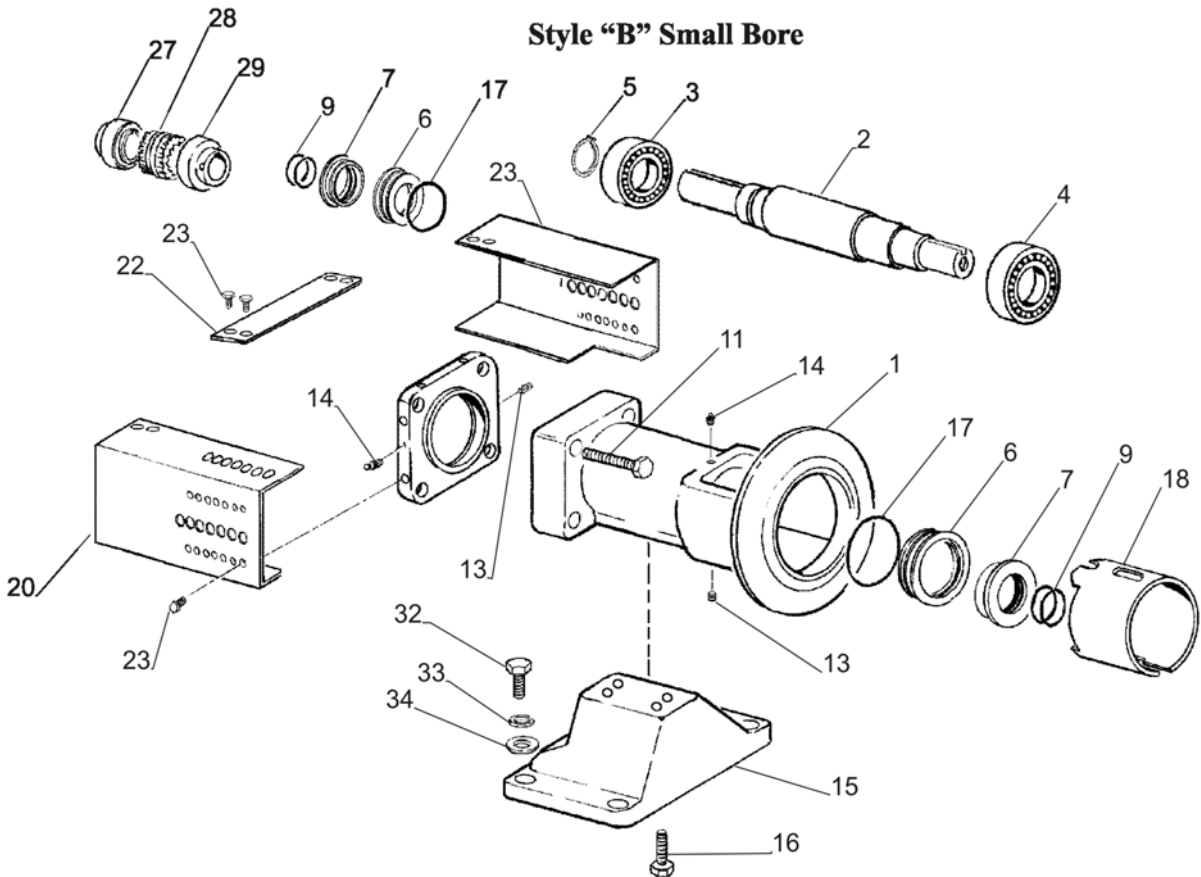


Leg Kits	
143-145JM	110256
182-184JM	110255
213-215JM	110254
254-256JM	110253
284-286JM	110252
324-326JM	110251

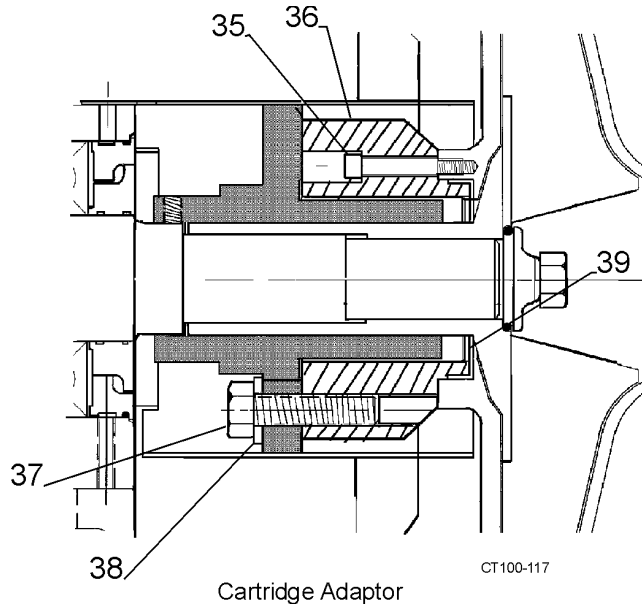
**Pedestal Mounted Pumps Small Bore**



**Style "B" Small Bore**



**Style "C" Small Bore**



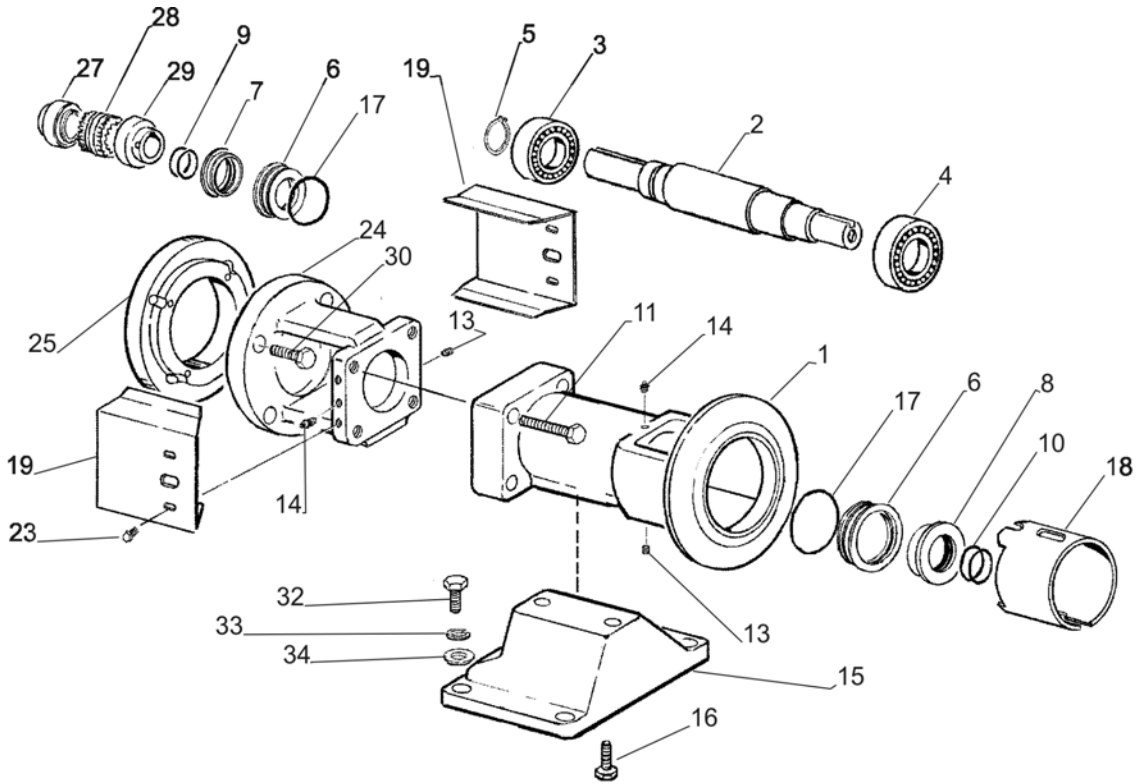
ITEM #	DESCRIPTION	STYLE	MOTOR	PART #
1	Bearing housing S2045	B,C	ALL	68-6
	S2065	B,C	ALL	68-7
	S2075-S2085-S2092	B,C	ALL	68-8
2	Shaft	B,C	ALL	62-528X
3	Bearing 6309	B,C	ALL	23-101
* 4	Bearing 6209	B,C	ALL	23-100
* 5	Retaining ring	B,C	ALL	43-139
6	Seal outer	B,C	ALL	23-90
7	Seal inner	B,C	ALL	23-89
* 9	031 O-ring inner	B,C	ALL	N70031
11	HHCS 1/2-13 x 2"	ALL	ALL	30-138X
13	SHSS 1/4-20 x 3/8"	B,C	ALL	30-178
14	Grease fitting	B,C	ALL	BD0092000
15	Stand	B,C	ALL	4-34
16	HHCS 1/2-13 x 1"	B,C	ALL	30-78X
* 17	041 O-ring outer	B,C	ALL	N70041
18	Cover seal S2065-S2092	B,C	ALL	70-33
	S2045	B,C	ALL	70-32
19	Cover coupling	B	ALL	70-31
23	HHCS 1/4-20 x 1/2" LG.	B,C	ALL	30-62

CT100-189

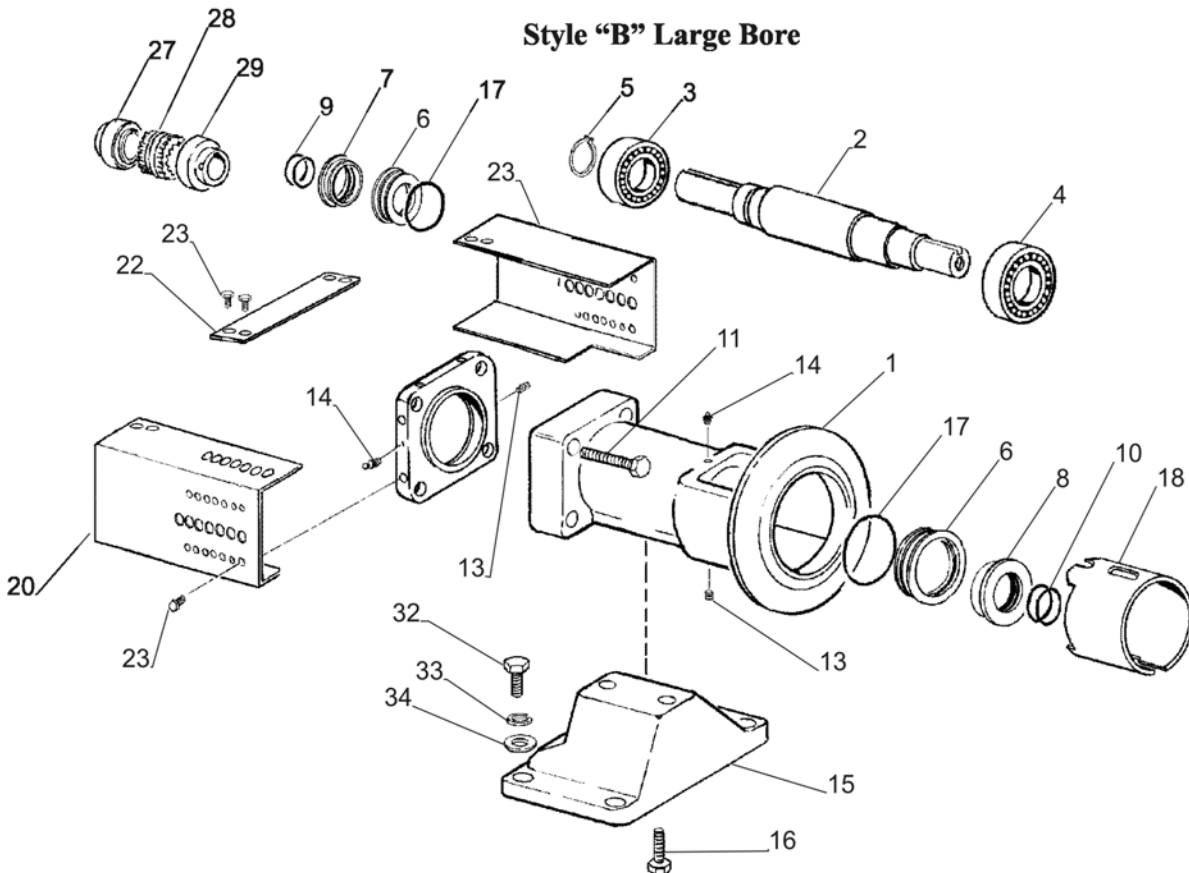
ITEM #	DESCRIPTION	STYLE	MOTOR	PART #	
24	Adapter	56C	B	56C	2-247
		56C	B	143TC	2-247
		56C	B	145TC	2-247
		182TC	B	182TC	2-248
		182TC	B	184TC	2-248
		182TC	B	213TC	2-248
		182TC	B	215TC	2-248
		182TC	B	254TC	2-248
		182TC	B	256TC	2-248
25	Spacer adapter	213TC	B	213TC	43-134
		213TC	B	215TC	43-134
		254TC	B	254TC	43-135
		254TC	B	256TC	43-135
27	Coupling half	.625 W	B,C	56	11-37
		.875 5S	B,C	143	11-101
		.875 5S	B,C	145	11-101
		1.125 5S	B,C	182	11-102
		1.125 5S	B,C	184	11-102
		1.375 6S	B,C	213-215	33220
		1.625 7S	B,C	254-256	33227
* 28	Coupling sleeve	4J	B,C	56	11-29
		5JE	B,C	143/184	11-30
		6JE	B,C	213/215	11-31
		7JE	B,C	254/256	11-32
29	Coupling half	1.0 4J	B,C	56	11-95
		1.0 5S	B,C	143/184	11-94
		1.0 6S	B,C	213/215	33217
		1.0 7S	B,C	254/256	33222
30	HHCS	3/8-16 x 1"	B	56/145	30-30X
		1/2-13 x 1"	B	182/184	30-78X
		1/2-13 x 1-3/4"	B	213/215	30-127X
		1/2-13 x 2-1/2"	B	254/256	30-87X
32	HHCS 1/2-13 x 1-1/2"	B,C	ALL	30-103	
33	Washer 1/2"	B,C	ALL	43-233	
34	Lock washer 1/2"	B,C	ALL	43-16	
35	SHCS 1/4-20 x 1-1/2"	B,C	ALL	30-222X	
36	Adapter, cartridge seal	B,C	ALL	23-91X	
37	HHCS 1/2-13 x 1-3/4"	B,C	ALL	30-127X	
38	Flat washer 1/2"	B,C	ALL	43-31X	
* 39	L-gasket	FKM	B,C	ALL	9-37
		EPDM	B,C	ALL	9-37E
		FFKM	B,C	ALL	9-37K

CT100-189a

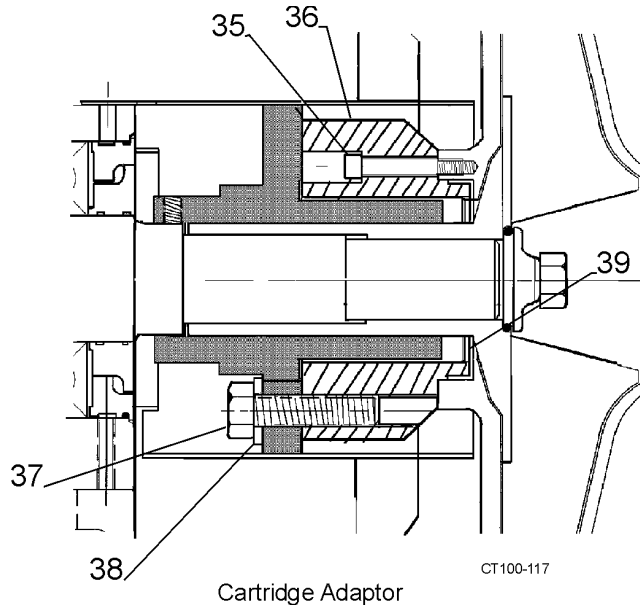
**Pedestal Mounted Pumps Large Bore**



**Style "B" Large Bore**



**Style "C" Large Bore**



ITEM #	DESCRIPTION	STYLE	MOTOR	PART #
1	Bearing housing S2065	B,C	ALL	68-9
	S2075-S2085-S2092	B,C	ALL	68-10
2	Shaft	B,C	ALL	62-539X
* 3	Bearing 5311	B,C	ALL	23-98
* 5	Retaining ring	B,C	ALL	43-138
6	Seal outer	B,C	ALL	23-95
7	Seal inner motor end	B,C	ALL	23-94
8	Seal inner motor impeller end	B,C	ALL	23-93
* 9	035 O-ring inner	B,C	ALL	N70035
* 10	033 O-ring inner impeller	B,C	ALL	N70033
11	HHCS 1/2-13 x 3-1/4"	ALL	ALL	30-221X
13	SHSS 1/4-20 x 3/8"	B,C	ALL	30-178
14	Grease fitting	B,C	ALL	BD0092000
15	Stand	B,C	ALL	4-35
16	HHCS 1/2-13 x 1-1/4"	B,C	ALL	30-36X
* 17	045 O-ring outer	B,C	ALL	N70045
18	Seal Guard S2065-S2085	B,C	ALL	70-33
19	Cover coupling adapter	B	ALL	70-34
20	Cover coupling L.H.	C	ALL	70-35
21	Cover coupling R.H.	C	ALL	70-36
22	Brace, cover coupling	C	ALL	2-252
23	HHCS 1/4-20 x 1/2" LG.	B,C	ALL	30-62

CT100-190

ITEM #	DESCRIPTION	STYLE	MOTOR	PART #	
24	Adapter	B	213TC	2-249	
		B	215TC	2-249	
		B	254TC	2-249	
		B	256TC	2-249	
		B	284TC	2-250	
		B	286TC	2-250	
		B	324TC	2-250	
		B	326TC	2-250	
		B	364TC	2-250	
25	Spacer adapter	B	254TC	43-134	
		B	256TC	43-134	
		B	324TC	43-136	
		B	326TC	43-136	
		B,C	364TC	43-137	
		B,C	365TC	43-137	
26	End cap housing LB	C	ALL	23-97	
27	Coupling half	1.375 6S	B,C	213-215	33220
		1.625 7S	B,C	254-256	33227
		1.875 7S	B,C	284	33229
		1.875 7S	B,C	286	33229
		2.125 8S	B,C	324-326	33237
		2.375 8S	B,C	364	11-107
		2.375 8S	B,C	365	11-107
28	Coupling sleeve	6JES	B,C	213/215	11-31
		7JES	B,C	254/286	11-32
		8JES	B,C	324/326	11-33
		8HSS	B,C	364/365	33189
29	Coupling half	1.250 6S	B,C	213/215	33219
		1.250 7S	B,C	254/286	33224
		1.250 8S	B,C	324/365	33230
30	HHCS 1/2-13 x 1-1/4"	1/2-13 x 1-1/4"	B	213/215	30-36X
		1/2-13 x 1-1/4"	B	324/365	30-21
32	HHCS 1/2-13 x 1-1/2"	B,C	ALL	30-103X	
33	Washer 1/2"	B,C	ALL	43-31X	
34	Lock washer 1/2"	B,C	ALL	43-16	
35	SHCS 1/4-20 x 1-1/2"	B,C	ALL	30-222X	
36	Adapter, cartridge seal	B,C	ALL	23-91X	
37	HHCS 1/2-13 x 1-3/4"	B,C	ALL	30-127X	
38	Flat washer 1/2"	B,C	ALL	43-31X	
39	L-gasket	FKM	B,C	ALL	9-37
		EPDM	B,C	ALL	9-37E
		FFKM	B,C	ALL	9-37K

CT100-190a

## Troubleshooting

PROBLEM	POSSIBLE CAUSE	SUGGESTED ACTION
<b>Not Enough Liquid Delivered</b>	Pump not primed.	Prime pump. Install a priming system if possible.
	Suction or discharge plugged or closed.	Open suction. If plugged <u>shutdown pump</u> and remove blockage.
	Air leak in supply or at seal area.	Check system for air leaks and repair as necessary. Replace seals if required.
	Wrong direction of rotation.	Adjust motor electrical wiring to correct rotation.
	Discharge head too high.	Lower discharge head requirement.
	Suction lift too high.	Lower pump in system until the pump is easily supplied with material.
	Speed too slow (low voltage, wrong frequency, wrong motor).	Adjust voltage and frequency. Change motor if necessary.
	Excessive air in material.	Adjust system to remove excess air from material before it reaches the pump.
	Insufficient NPSH (Net Positive Suction Head) available.	Adjust system to provide correct NPSH.
Impeller diameter too small for duty.	Contact your Waukesha Cherry-Burrell customer service representative for sizing information. WCB Customer Service Telephone: 1-800-252-5200 Or 262-728-1900	
<b>Not Enough Pressure</b>	Air leak in supply or at seal area.	Check system for air leaks and repair as necessary. Replace seals if required.
	Wrong direction of rotation.	Adjust motor electrical wiring to correct rotation.
	Speed too slow (low voltage, wrong frequency, wrong motor).	Adjust voltage and frequency. Change motor if necessary.
	Excessive air in material.	Adjust system to remove excess air from material before it reaches the pump.
	Impeller diameter too small for duty.	Contact your Waukesha Cherry-Burrell customer service representative for sizing information. WCB Customer Service Telephone: 1-800-252-5200 Or 262-728-1900
<b>Motor Overload</b>	Faulty electrical connections.	Check wiring and repair/replace as necessary.

Unrestricted discharge resulting in too high a flow rate.	Add discharge restriction to lower flow rate.
Impeller interference.	Disassemble pump and inspect for damage. Remove interference if still present. Replace worn/damaged parts.
Seal binding.	Disassemble pump and inspect for damage. Check for material crystallization on seals.
Discharge head too low allowing pump to deliver too much liquid.	Raise discharge head until pump achieves proper resistance to flow.
Liquid heavier or more viscous than rating.	Contact your Waukesha Cherry-Burrell customer service representative for sizing information. WCB Customer Service Telephone: 1-800-252-5200 Or 262-728-1900
Overload heaters too small for motor.	Inspect and replace as necessary.
Electrical supply, voltage, frequency, incorrect.	Adjust voltage and frequency. Change motor if necessary.
Impeller diameter too large for duty.	Contact your Waukesha Cherry-Burrell customer service representative for sizing information. WCB Customer Service Telephone: 1-800-252-5200 Or 262-728-1900
Defective motor.	Replace motor.

---

## Vibration/Noise

Pump not level.	Make sure all legs are touching the floor. Level pump.
Piping not supported.	Support all piping as described in the installation section.
Starved suction/Supply line blocked.	<u>Shutdown pump</u> and remove blockage.
Foreign material in pump.	Disassemble pump, remove all foreign material and inspect for damage. Replace worn/damaged parts.
Starved suction/Insufficient NPSH (Net Positive Suction Head) available.	Adjust system to provide correct NPSH.
Impeller hub/impeller shaft worn.	Disassemble pump and inspect for damage. Replace worn parts.
Impeller shaft loose or bent.	Disassemble pump and inspect for damage.

	Impeller out of balance.	Disassemble pump and inspect for damage. Replace impeller.
	Motor bearings worn.	Disassemble motor and inspect for damage. Replace worn parts.
	Starved suction/supply line too long.	Shorten system supply line.
	Starved suction/supply line too small.	Install larger supply lines.
	Excessive air in material.	Adjust system to remove excess air from material before it reaches the pump.
<b>Rapid Seal Wear</b>	Incorrect impeller shaft location; excessive spring loading.	Adjust pump alignment to motor and piping.
	Water Hammer.	Adjust system to reduce air in system and sudden starts or stops in flow.
	Impeller shaft loose or bent.	Disassemble pump and inspect for damage. Replace worn/damaged parts.
	Abrasive product.	Contact your Waukesha Cherry-Burrell customer service representative for sizing information. WCB Customer Service Telephone: 1-800-252-5200 Or 262-728-1900
	Prolonged “dry” running.	Adjust process to insure pump has a continual fresh supply of product during operation.
	Abrasive solids (unfiltered) in flush water supplied to seal.	Use only filtered water in seal flush system.
<b>Seal Leaks</b>	Gasket damaged or worn.	Disassemble pump and inspect for damage.
	Seal not installed correctly.	Disassemble pump and inspect seal for damage (replace if necessary). Install seal correctly and assemble pump.
	Carbon seal worn or damaged.	Disassemble pump and inspect seal for damage (replace if necessary).
	Inlet/Outlet connection loose or no gasket.	Inspect Inlet/outlet connection for gasket and tighten connection.
	Casing clamp loose.	Tighten clamp.

# NOTES



# **SPX** Process Equipment

611 Sugar Creek Road • Delavan, WI 53115 USA

Tel: (800) 252-5200 or (262) 728-1900 • Fax: (800) 252-5012 or (262) 728-4904

E-mail: [info@processequipment.spx.com](mailto:info@processequipment.spx.com) • Web site: [www.spxprocessequipment.com](http://www.spxprocessequipment.com)

Issued Date: January 2005 • Revision Date: June 2005

95-03080