

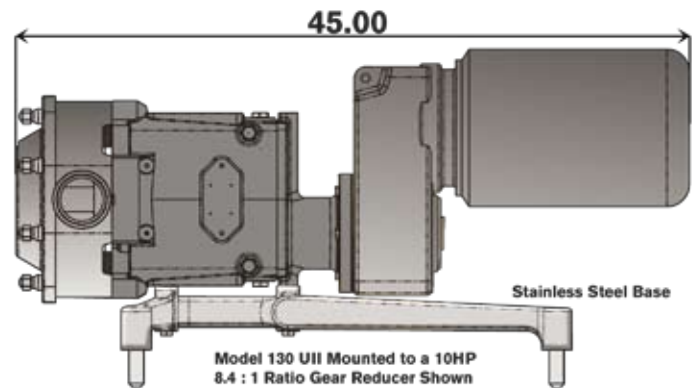

Tru-Fit™ Pump Drive

Compare the Difference

- No shaft alignment necessary
- No coupling guard required
- Available for models 006 through 320 UI, UII, UL
- Special base design enhances cleanability
- Reduces overall length of complete unit by an average of 20-25%
- Average of 10-20 gear ratios available per horsepower
- NEMA or IEC frames available, right angle reducer also available for additional space savings
- 1/2 through 60 horsepower drive options available
- Horizontal or vertical porting available
- Separate oil sump for gear reducer and timing gears
- Optional stainless steel leg kits available
- Easy to maintain



Conventional Drive Configuration

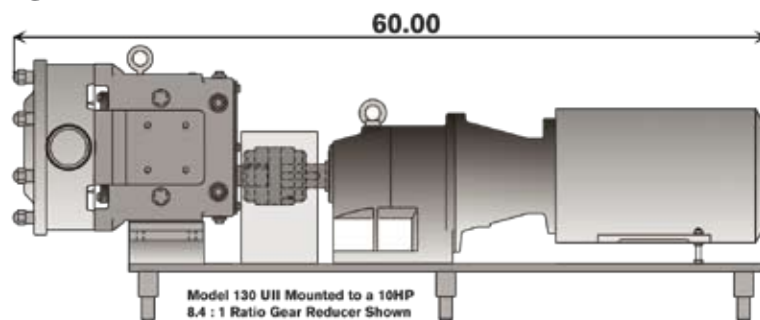

SPX Process Equipment, 611 Sugar Creek Road, Delavan, WI 53115
Phone: (262) 728-1900 or (800) 252-5200 Fax: (262) 728-4904 or (800) 252-5012
E-mail: wcb@spx.com

For more information about our worldwide locations, approvals, certifications, and local representatives, please visit www.spxpe.com.

SPX reserves the right to incorporate our latest design and material changes without notice or obligation.

Design features, materials of construction and dimensional data, as described in this bulletin, are provided for your information only and should not be relied upon unless confirmed in writing.

Issued: 03/2009 FH-1752

Copyright © 1903, 2009 SPX Corporation