

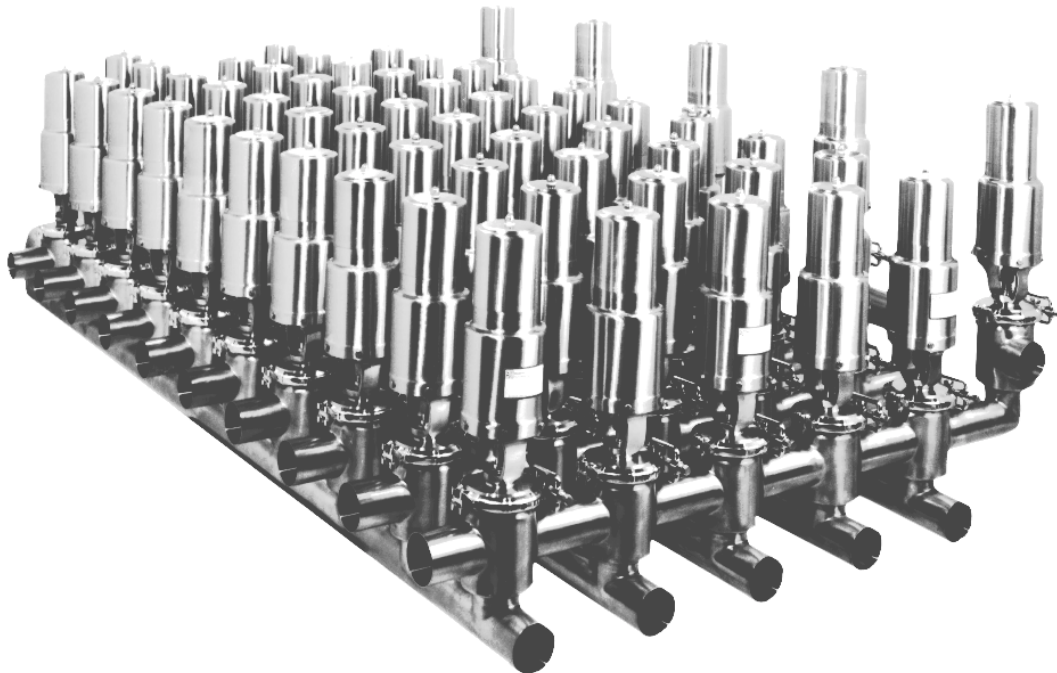

**Waukesha
Cherry-Burrell**

Read and understand this manual prior to installing, operating or maintaining this valve.



**Cherry-Burrell
Series 61 & 62
Automatic Valves
and Manifolds**

**OPERATION
MAINTENANCE
& PARTS LIST**



SAFETY

Warnings, cautions and notes are contained in this manual. To avoid serious injury and/or possible damage to equipment, pay attention to these messages.

WARNING Hazards or unsafe practices which **COULD** result in severe personal injury or death and how to avoid it.

CAUTION Hazards or unsafe practices which **COULD** result in minor personal injury or product or property damage.

NOTE Important information pertaining directly to the subject.
(Information to be aware of when completing the task.)

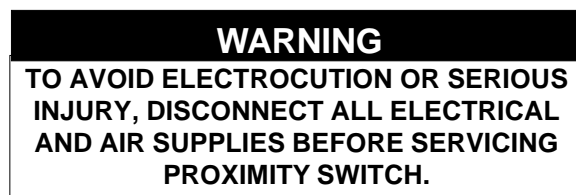
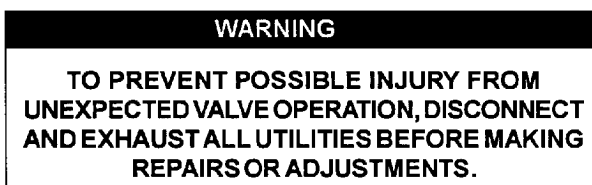
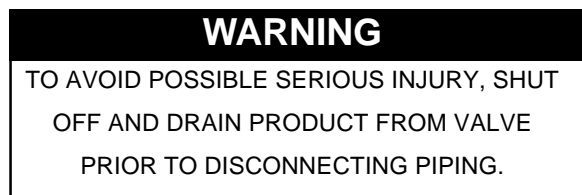

REPLACEMENT LABEL



REPLACEMENT LABEL

Read and understand this manual prior to installing, operating or maintaining this valve.

WAUKESHA CHERRY-BURRELL WARRANTY

Seller warrants its products to be free from defects in materials and workmanship for a period of one (1) year from the date of shipment. This warranty shall not apply to products which require repair or replacement due to normal wear and tear or to products which are subjected to accident, misuse or improper maintenance. This warranty extends only to the original Buyer. Products manufactured by others but furnished by Seller are exempted from this warranty and are limited to the original manufacturer's warranty.

Seller's sole obligation under this warranty shall be to repair or replace any products that Seller determines, in its discretion, to be defective. Seller reserves the right either to inspect the products in the field or to request their prepaid return to Seller. Seller shall not be responsible for any transportation charges, duty, taxes, freight, labor or other costs. The cost of removing and/or installing products which have been repaired or replaced shall be at Buyer's expense.

Seller expressly disclaims all other warranties, express or implied, including without limitation any warranty of merchantability of fitness for a particular purpose. The foregoing sets forth Seller's entire and exclusive liability, and Buyer's exclusive and sole remedy, for any claim of damages in connection with the sale of products. In no event shall Seller be liable for any special consequential incidental or indirect damages (including without limitation attorneys' fees and expenses), nor shall Seller be liable for any loss of profit or material arising out of or relating to the sale or operation of the products based on contract, tort (including negligence), strict liability or otherwise.

TABLE OF CONTENTS

SERIES 61 AND 62 AUTOMATIC VALVES AND MANIFOLDS

SAFETY	3	CARE OF STAINLESS STEEL	13
WARRANTY	4	PARTS ORDERING INFORMATION	14
INTRODUCTION	6	Valve Identification Information	
Specifications		How to Order	
How to Identify Models		How to Return	
Valve Components/Features	7	SERVICE NOTES	15
INSTALLATION	8	ILLUSTRATED PARTS LISTS	
Inspection on Arrival	8	Valve Bodies	
Pipeline Supports	8	Single Body Valves-316 Stainless	16-17
Installing Valve Manifolds	6	Double Body Valves- 316 Stainless	18-19
Valve Dimensions (<i>See Appendix A</i>)		Actuators	
Pressure Drop (<i>See Appendix B</i>)		4" Actuator	20-21
Actuator Air Connections	7	5" Actuator	20-21
Air Pressure and Volume	7	4" - Three Position Actuator	22-23
Effective Area	7	4" Micro switch Actuator	24-25
Hand Actuator	7	5" Micro switch Actuator	24-25
Cleaning		Hand Actuator	26
C.I.P. Cleaning	8	APPENDIX A - Valve Dimensions	27-28-29
MAINTENANCE		APPENDIX B - Pressure Ratings	30
Removal and Installation of Teflon		APPENDIX C - Seat Ring and Valve Stem	
Seat Rings	8	Cross Reference Chart	31
Can You Interchange your Old		REFERENCE DATA	
Stem ?	9	Stainless Steel Tubing	32
(<i>See Appendix C for Stem Identification</i>)		Size (O.D.)	
Reversing Action of Valve	10	Volume (Cu. In per ft.)	
Reversing Action of Micro switch		Gallons (Per foot of length)	
Actuator	11	Pipe Size Schedules	32
Replacement		Size (Nominal I.D.)	
U-Cup Seal	11	Volume (Cu. In per ft.)	
Piston Rod, O-Ring	12	Gallons (Per foot of length)	
Limit Switch	12	EQUIVALENT CHARTS	32
Limit Switch Adjustment	12	FRICITION HEAD PER 100 FT OF	
		STAINLESS STEEL TUBING	32

INTRODUCTION

INTRODUCTION

If your sanitary or industrial process flow control job demands top quality valves for utmost process efficiency--Waukesha Cherry-Burrell offers the products you need.

For industries handling liquid or semi-liquid products, our automatic air-actuated valves are the most economical means to obtain push-button processing with automated flow control.

All Cherry-Burrell style valves are quality-crafted from stainless steel, and meet 3A standards for sanitation, dimension, and style.

There are four basic types of valve actuators--all designed with stainless steel external parts.

Most applications make use of the economical 4" fully automated actuator.

When higher than normal holding pressures are required, the 5" actuator is the answer. And, for especially large jobs, a 6" air-to-raise actuator is available for use on 6" valves.

All standard 4", 5", and hand-operated actuators will fit any series 61 or 62 valve body, and are completely interchangeable (and reversible) in the field using ordinary hand tools.

SPECIFICATIONS

Effective area of actuators:

4" AR and 4" ABW = 12.12 sq. in.
4" AL and 4" ABW = 12.57 sq. in.
5" AR and 5" ABW = 19.19 sq. in.
5" AL and 5" ABW = 19.63 sq. in.

Effective valve plug area:

size	lower	upper
1½"	1.760 sq. in.	1.318 sq. in.
2"	3.132 sq. in.	2.690 sq. in.
2½"	4.897 sq. in.	4.455 sq. in.
3"	7.054 sq. in.	6.612 sq. in.
4"	12.548 sq. in.	12.106 sq. in.

Air supply requirements:

Air pressure range is 50 to 75 psi

Air volume required:

4" AR--12.7 cu. in.
4" AL--14.7 cu. in.
5" AR--21.5 cu. in.
5" AL--27.9 cu. in.
4" ABW--26.6 cu. in.
5" ABW--62.4 cu. in.

AR=AIR-TO-RAISE

AL=AIR-TO-LOWER

ABW=AIR-BOTH-WAYS

HOW TO IDENTIFY MODELS

Body

Designation: T = Tee F = Flange
C = Cross OP = Offset Port

When describing a valve, the model number comes first, then the body designation. On double body valves, upper body is designated first, then lower body, i.e., Model 62-CT means a double body valve with the upper body being a Cross and the lower body being a Tee.

Examples

- Model 61 - Single Body Air Operated
- 62 - Double Body Air Operated
- 61-TF - Tank Outlet Valve, Flange Mounted, Air Operated
- 61-TFOP - Tank Outlet Valve With Offset Port, Flange Mounted, Air Operated

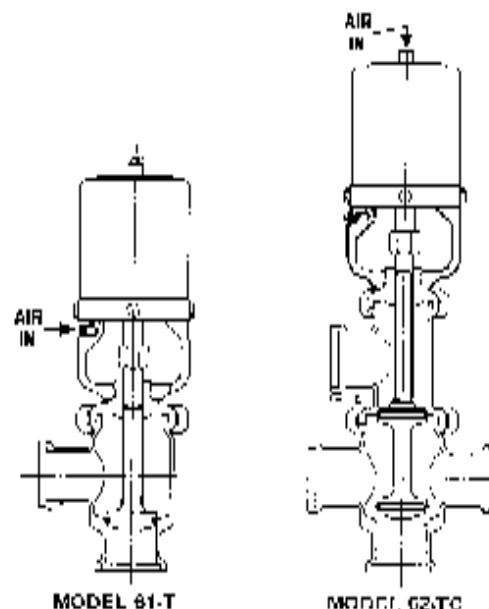

Figure 1. Example Body Designations

VALVE COMPONENTS /FEATURES

VALVE COMPONENTS/FEATURES

The cutaway view in Figure 2 shows a hand-polished stainless steel double-body model of heavy-duty design.

The exterior surface is made of easy-to-maintain 316 stainless steel for sanitary operations. For industrial uses where sanitation is not critical, an unpolished finish is also available.

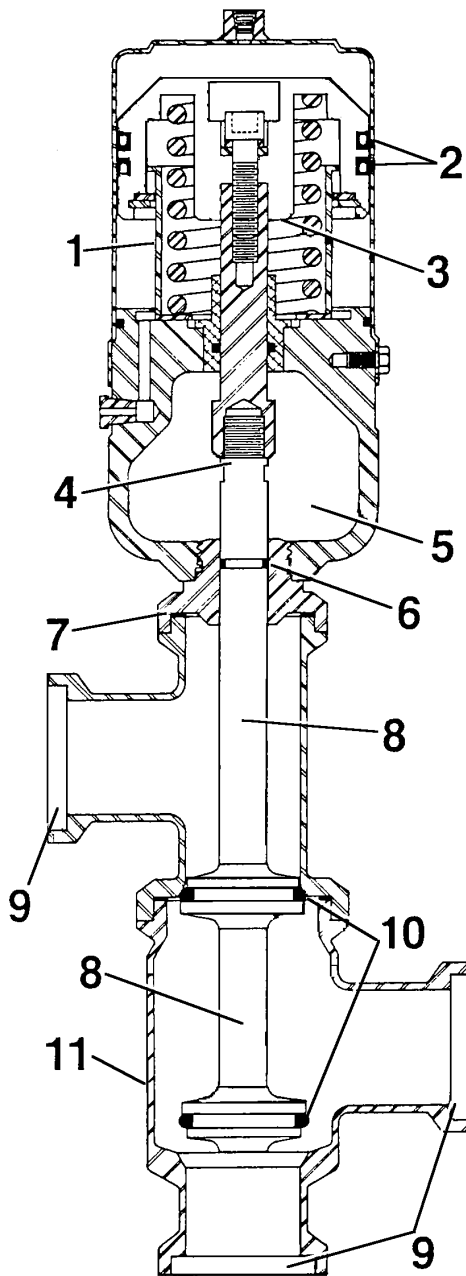

Figure 2.

1. 4", 5", or hand actuators, are interchangeable on all Cherry-Burrell Automatic valve bodies.

2. Piston U-cups provide sealing against air pressure.

3. Cherry-Burrell automatic valves are fail-safe, due to the positive piston action provided by the actuator spring. In the event of air failure, the valve opens or closes depending upon the type of valve actuator. Valve action can be set for air-to-raise or air-to-lower. The mode of action can easily be reversed in the field.

4. Valve stem is detachable without disassembly of the actuator.

5. Wide, open-yoke design shows stem position and prevents product from leaking into the actuator.

6. Neoprene O-ring stem seal.

7. Rigid actuator-to-valve assembly using "I"-clamp connection assures positive alignment.

8. Heavy-duty 3/4" stem for greater strength.

9. Product inlets and outlets can be equipped with "I"-, "S"-, "Q"-clamp, butt-weld, or bevel-seat fittings for 1½-, 2-, 2½-, 3-, and 4-inch size valves. 6-inch size available with I-clamp, flange, or butt-weld only.

10. Cherry-Burrell's exclusive Teflon seat rings on the valve stem are completely chemically inert, able to withstand high temperatures, and economically field replaceable. Rings provide a positive seal and are of sanitary design to permit CIP cleaning. Optional lapped metal seats are available for extreme temperature applications.

11. Valve body can be turned to a full 360° for ease of installation with any existing system.

INSTALLATION

INSTALLATION

INSPECTION ON ARRIVAL

Each valve is inspected prior to shipping. Upon arrival, carefully check for damage that may have occurred in transit. (Refer to Figure 1.) If any damage is found, immediately notify the applicable freight agent and then file a claim. The transportation company is responsible for any loss or damage during shipment.

PIPELINE SUPPORTS

As a general rule, support pipelines in such a way that they "float". This is particularly important when lines contain automatic valves; temperature changes in the lines may cause expansion and contraction that can distort valve bodies causing leaks.

Install adequate supports to prevent strain on fittings, valves, and equipment connections. (See Figure 3.)

- Install supports on straight runs of piping at least every ten feet, (C)
- Install supports on both sides of valves as close to the connections as possible. (D)
- Install supports at each change of pipeline direction. (E and F)
- For pipelines passing through walls, floors, or ceilings, provide at least one inch of clearance around the pipe to allow for expansion and contraction. (G)



CAUTION

Before attempting to butt-weld an automatic valve into a line, disassemble the body from the actuator. Dissipate heat away from the valve body to prevent warping.

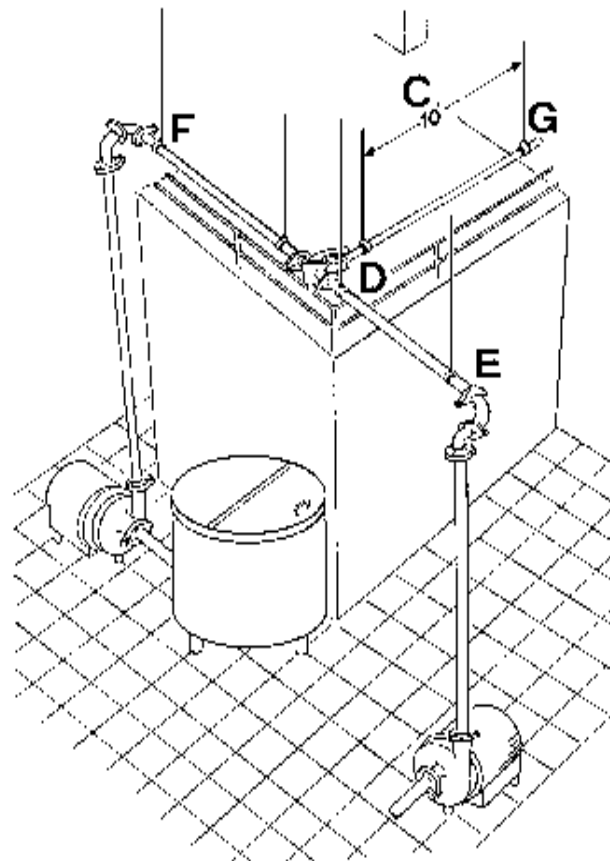

Figure 3. Pipeline Support Recommendations

INSTALLING VALVE MANIFOLDS

Install automatic valve clusters with a uniform pitch for proper drainage. Elevate one corner of the cluster and pitch 1/16 in. per foot. Arrange supports for floor mounted valve clusters to provide proper alignment of inlet and outlet lines.

VALVE DIMENSIONS

Refer to Appendix A for dimensions of valves.

PRESSURE DROP

Refer to Appendix B for pressure drop ratings of valves.

AIR CONNECTIONS

AIR CONNECTIONS

Use 1/4" flexible tubing such as Poly-Flo or Tygon, with an adapter reduced to 1/8" NPT at the valve connection.

1. For two position actuators, make the connection as shown in Figure 4.
2. For three position actuators, make the connections as shown in Figure 5.

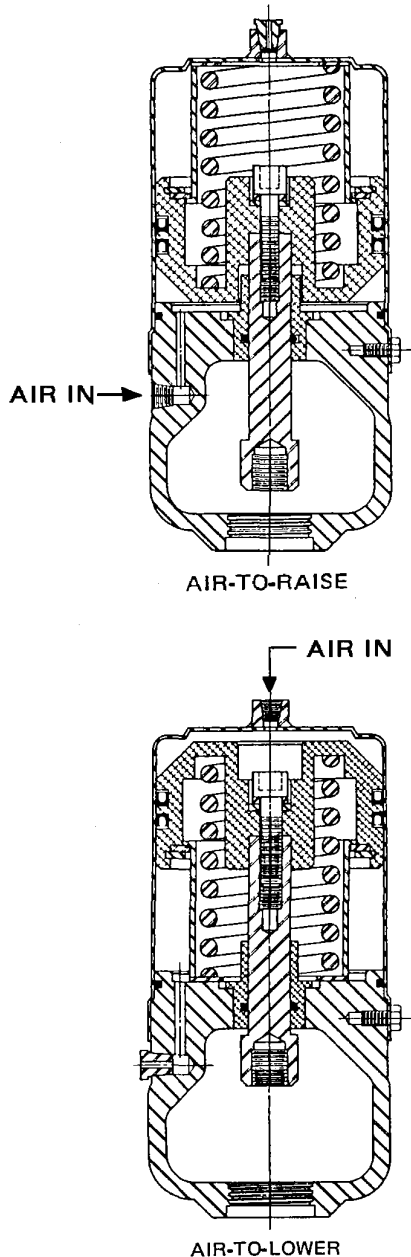

Figure 4. Air Line Connections for Two Position Actuators

AIR PRESSURE AND VOLUME

Provide between 50 PSIG and 75 PSIG air pressure; 60 PSIG is most desirable. Air must be clean and dry; filtering is required.

Specifications

Effective area of actuators:

4" AR and 4" ABW	= 12.12 sq. in.
4" AL and 4" ABW	= 12.57 sq. in.
5" AR and 5" ABW	= 19.19 sq. in.
5" AL and 5" ABW	= 19.63 sq. in.

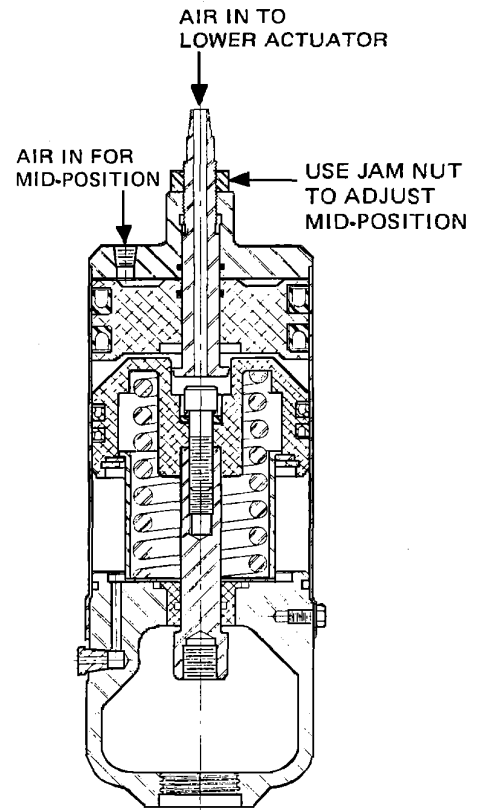

Figure 5. Air Line Connections for Three Position Actuators

CLEANING - MAINTENANCE

CLEANING

C. I. P. CLEANING

Cleaning in place (CIP) methods can be used to clean installed automatic valves without disassembly. The methods must be selected subject to the specific requirements of each application and the sanitarians. Check with local chemical suppliers for the most effective cleaning agents and procedures.



NOTE

Actuate each valve twice during the rinsing, washing, rinsing, and sanitizing procedures.



CAUTION

During clean-up, avoid splashing any solutions into the air vent of the actuator.

MAINTENANCE

REMOVAL AND INSTALLATION OF TEFLON SEAT RINGS

1. When the seat ring has been damaged and must be replaced, remove it by first carefully cutting through the ring with a sharp knife.

CAUTION

DO NOT scratch or nick the bottom or side of the stem groove. Clean the groove thoroughly of all residue and deposits.



NOTE

Before a new seat ring can be installed, it must first be softened to approximately 350° F.

2. Heat U.S.P. propylene glycol to boiling (188°C. - 370°F.)
3. Place the ring in boiling glycol for several minutes to soften it.



CAUTION

If the glycol is being heated using a hot plate or Bunsen burner, be sure that the seat ring does not come in contact with the container bottom. Place the ring on a small support (piece of wood or equivalent) in the container.

4. Remove the seat ring carefully using tongs, wooden pencil, wire or suitable rod.



WARNING

Be sure to wear gloves or use an insulating cloth to prevent burns--you will be handling a very hot object.

TEFLON SEAT RING REPLACEMENT

- Using gloves or an insulating rag, carefully place the ring into the stem groove with the seat chamfer positioned as shown in Figure 6. Apply uniform pressure with the thumbs to slightly stretch the ring and cause it to snap fully into the groove.

CAUTION

DO NOT attempt to stretch the ring any more than is required to install. Gently roll the ring over the lip of the stem groove until it is fully seated.

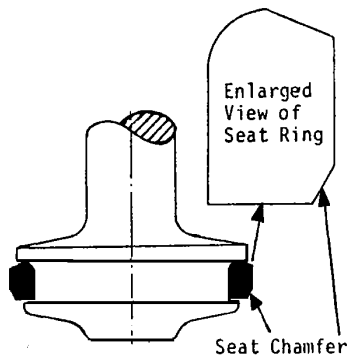

Figure 6. Seat Ring Positioning

- Place the stem and ring in cool water. This will help relax the stress caused during stretching, and will cool the ring.

CAN YOU INTERCHANGE YOUR OLD STEM?

Valve stems are interchangeable, but the teflon seat rings are not. i.e. A new style valve stem can be used to replace an old style valve stem but a new style teflon seat ring must be used on it.

See Appendix C for a Cross Reference Chart of old vs. new valve stems.

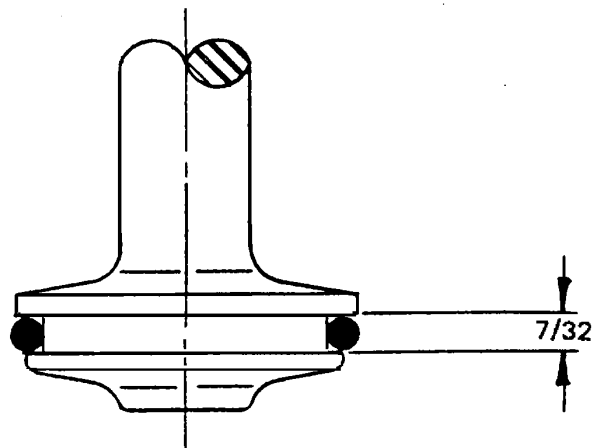

OLD STYLE STEM
 $1\frac{1}{2}$ ", 2", $2\frac{1}{2}$ " used before 1980;
3" used before 1977.

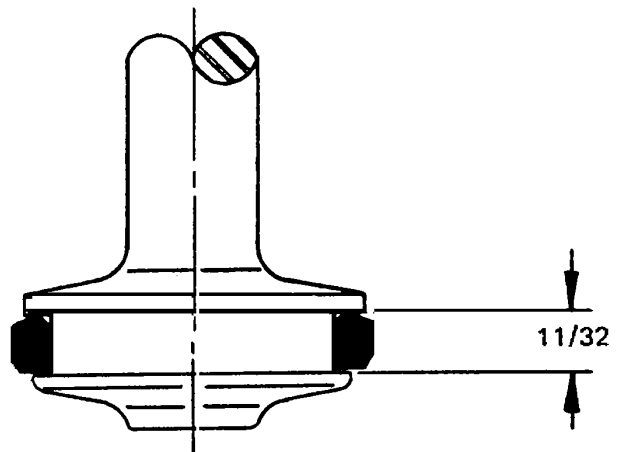

NEW STYLE STEM
 $1\frac{1}{2}$ ", 2", $2\frac{1}{2}$ " used after 1980;
3" used after 1977.

Figure 7. Old Style vs. New Style Stems

REVERSE VALVE ACTION

REVERSING ACTION OF VALVE (From Air-to-Raise or from Air-to-Lower)

Note



NOTE

Actuator A1 3-4 cannot be reversed. A 5" actuator is reversed the same way as a 4" actuator.



WARNING

Do not attempt to disassemble the spring in the actuator. This can be dangerous as the spring is under compression.

1. Remove the capscrews and pull off the cover.
2. Using an Allen wrench, remove the $7/16$ " bolt located in the center of the actuator. See Figure 8.
3. Turn the entire assembly upside down.
4. Replace the $7/16$ " bolt and washers.

NOTE

Apply a coating of orange solid oil to all O-Rings and U-Cups and Seals at time of replacement.

5. Replace cover and capscrews.
6. Reverse the plug vent.
 - A. For air-to-raise, plug vent should be on top of actuator cover.
 - B. For air-to-lower, plug vent should be at side of actuator just below the cover.

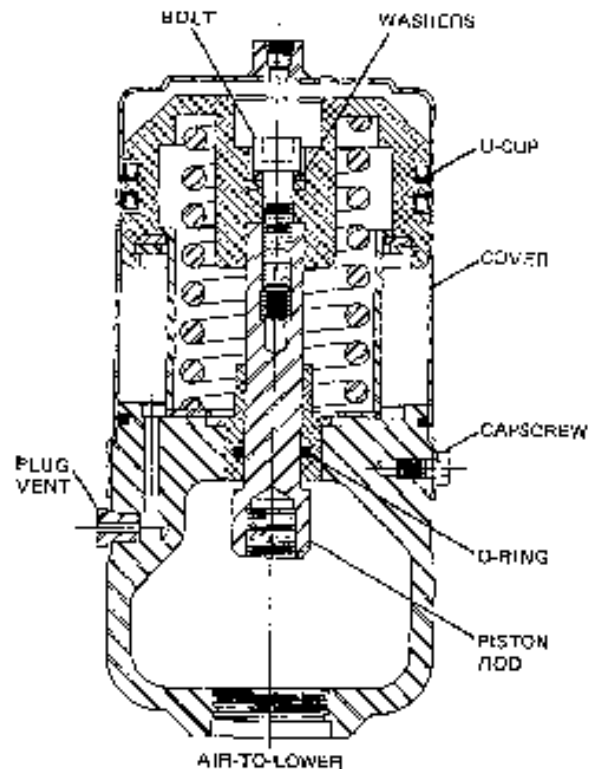
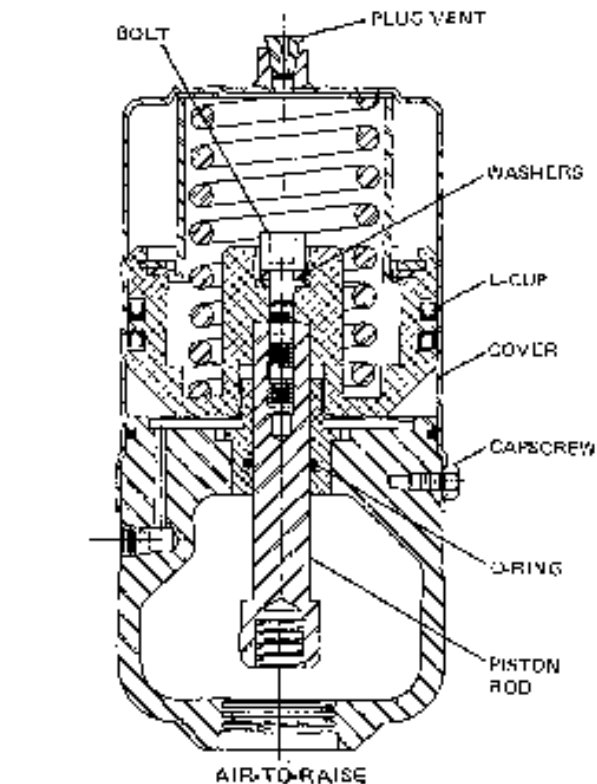

Figure 8. Reversing Valve Action

REVERSE MICRO SWITCH ACTION

REVERSING ACTION OF MICROSWITCH ACTUATOR

1. Remove the capscrews and pull cover off. See Figure 9.
2. Remove the round head machine screws and retainer cup that holds the actuator rod assembly to the piston.



NOTE

The round head screws are secured with loctite and may require considerable force to remove.

3. Remove the actuator rod assembly and the small compression spring.
4. Using an Allen wrench, remove the 7/16" socket-head capscrew in the center of the actuator.
5. Turn the entire assembly upside down.
6. Replace the 7/16" capscrew and washers.
7. Replace the small compression spring and actuator rod assembly using the round head machine screws (secure them with loctite).
8. Replace cover with capscrews.
9. Reverse plug vent:
 - a) Air-to-raise plug vent should be in actuator can.
 - b) Air-to-lower plug vent should be in yoke.

U-CUP SEAL REPLACEMENT

1. Remove the capscrews from around the base of the actuator cover.
2. Use air pressure through the yoke air port to break the actuator cover loose.
3. Lift off the cover and set it aside.
4. Remove the worn U-cup seals.



CAUTION

Avoid scoring or nicking the piston during seal removal and installation.

5. Apply a coating of orange solid oil no. 2, or equivalent, to all surfaces of the new seals.

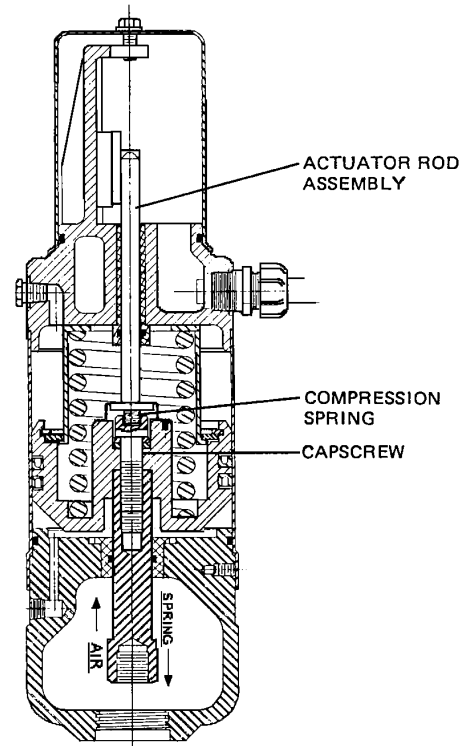

Figure 9. Reversing of Microswitch Actuator

6. Stretch the lubricated seals lightly to fit over the piston as shown in Figure 10). (Note that the U-cup seals are flared slightly at the outer edges when properly installed.) Install the lower seal first with the U-cup shoulders pointing downward.

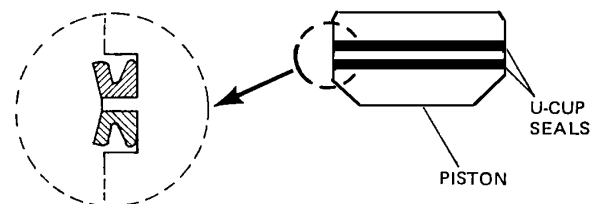

Figure 10. Piston Seal Replacement

7. Reinstall the actuator cover.

REPLACEMENTS

PISTON ROD O-RING SEAL REPLACEMENT

1. Remove screws from actuator cover.
2. Remove actuator cover.
3. Using an Allen wrench, remove the 7/16" bolt. See Figure 8.
4. Remove piston rod from yoke and remove O-ring from bushing, being careful not to score or nick the bushing during removal.
5. Coat the new O-ring with orange solid oil no.2 (or equivalent) and install it in the bushing.
6. Carefully install piston rod in yoke, being careful not to cut O-ring.
7. Assemble actuator in reverse order.

LIMIT SWITCH ASSEMBLY MAINTENANCE

For all limit switch maintenance procedures, remove the two capscrews and the switch assembly cover (Figure 11).



WARNING

Disconnect all applicable electrical power before removing the switch assembly cover.

When installing a new switch, always check the positioning for correct operation. Use the following procedure to replace either switch no. 1 and switch no.2.

1. With all electrical power disconnected, pull the wire clips straight off the switch terminals.
2. Remove the two capscrews going through the switch body.
3. Install the new switch and tighten both cap screws.
4. Use air to alternately raise or lower the actuator rod fully.
 - A. Switch no.1 should not be actuated when the actuator rod is fully down, as in Figure 11. Its roller operator should be directly over, and nearly touching,

the chamfer on the actuator rod. The switch should be mounted such that, as the rod extends, the crest of the chamfer pushes the roller operator aside and the "normally open" contacts close.

- B. Switch no. 2 should be at rest until the actuator rod fully extends. At this time, the crest of the rod chamfer pushes the roller operator aside and the "normally open" contacts close.
 - C. If side-to-side repositioning is necessary, loosen the cap screws holding the switch blocks shown in Figure 11. Adjust as needed and tighten the cap screws.
 - D. If a switch must be repositioned up or down, loosen the height adjusting capscrew on the back and adjust as necessary. Tighten the capscrew fully when the adjustment is completed.
5. Push the wire connectors onto the switch terminals. Refer to the wire color coding, shown in the micro-switch wiring detail drawing on page 23 and 25.

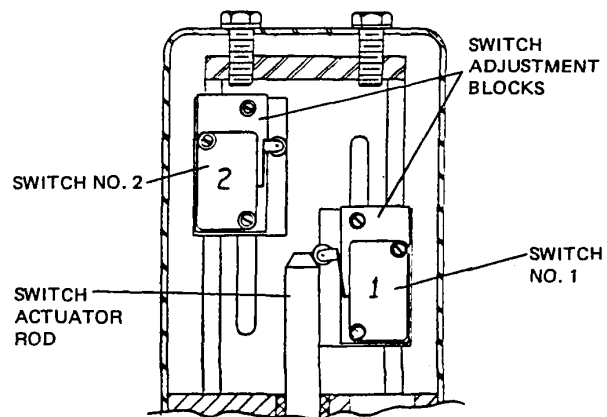

Figure 11. Switch Assembly

CARE OF STAINLESS STEEL

The stainless steel components in Waukesha Cherry-Burrell equipment are machined, welded and assembled by skilled craftsmen using manufacturing methods that preserve the corrosion-resistant quality of the stainless steel.

Retention of corrosion-resistant qualities under processing conditions requires regular attention to the precautions listed below.

(Note: Corrosion resistance is greatest when a layer of oxide film is formed on the surface of stainless steel; should this film be disturbed or destroyed, stainless steel becomes active and much less resistant to corrosion.)

1. Regularly check all electrical devices connected to the equipment in any way for stray currents caused by improper grounding, damaged insulation or other defects.

Corrosion: *"Pitting" often occurs when stray currents come in contact with moist stainless steel.*

2. Never leave rubber mats, fittings, wrenches, etc. in contact with stainless steel.

Corrosion: *Pitting or galvanic action. Objects retard complete drying, preventing air from reforming the protective oxide film. Galvanic corrosion occurs when two dissimilar metals touch when wet.*

-. Use water conditioner when the water supply contains foreign matter which may cause discoloration or deposits.

Corrosion: *Pitting, deposits, discoloration. Deposits counteract the best cleaning practices and cause corrosion of the best quality stainless steel.*

4. Immediately rinse equipment after use with warm water until the rinse water is clear. Clean the equipment (manual or CIP) as soon as possible after rinsing.

Corrosion: *Discoloration, deposits, pitting. Product deposits often cause Pitting beneath the particles.*

5. Use only re-commended cleaning compounds. Purchase (chemicals from reputable and responsible chemical manufacturers familiar with stainless steel processing, equipment. They continuously check the effects of their products on stainless steel.

6. Use cleaning chemicals exactly as specified by the manufacturer. Do not use excessive concentrations, temperatures or exposure times.

Corrosion: *Pitting, discoloration, stress- cracks. Permanent damage often occurs from excessive chemical concentrations, temperatures, or exposure times.*

7. For manual cleaning, use only soft non metallic brushes, sponges or pads. Brush with the grain on polished surfaces; avoid scratching the surface.

Corrosion: *Pitting, scratches. Metal brushes or sponges will scratch the surface and promote (corrosion over a period of time. metal particles allowed to remain on a stainless steel surface will cause pitting.*

8. Use chemical bactericides exactly as prescribed by the chemical manufacturer in concurrence with local health authority. Use the lowest permissible concentration, temperature and exposure time possible. Flush immediately after bactericidal treatment. In no case should the solution be in contact with stainless steel more than 20 minutes.

Corrosion: *Protective film destroyed. Chlorine and other halogen bactericides can destroy the protective film. A few degrees increase in temperature greatly increases chemical activity and accelerates corrosion.*

9. Regularly inspect the joints in pipelines. Be sure all connections are tight fitting without binding.

Corrosion: *Crevice corrosion. Small crevices caused by improperly seated gaskets will promote crevice corrosion. Stainless steel under stress will develop stress cracking especially in the presence of bactericides containing chlorine.*

10. Regularly inspect equipment for surface corrosion (i.e. pitting, deposits, stress cracks, etc.). If deposit or color corrosion is detected, remove it immediately using mild scouring powder and detergents. Rinse thoroughly and allow to air dry. Review production and cleaning procedures to determine the cause.

Note: *If corrosion is not removed, the protective film cannot be restored and corrosion will continue at an accelerated rate.*

PARTS ORDERING

EQUIPMENT INFORMATION

Any correspondence concerning valves will require the following information be documented:

PRODUCT NAME/MODEL: _____

PRODUCT SERIAL NUMBER: _____

DATE OF PURCHASE: _____

INVOICE NUMBER: _____

INVOICE DATE: _____

HOW TO ORDER PARTS

By Phone

Telephone your repair parts or fittings order to your Distributor.

To speed your order and avoid delays, please have your **equipment model** and **serial number** and the **part numbers** from the parts list before you call your Distributor.

If you do not know your Distributors number, call Waukesha Cherry-Burrell Customer Service at:

Phone: **800-252-5200 or 414-728-1900**

Fax: **800-252-5012 or 414-728-4904**

Your call will be directed to a specialist who can provide you with Distributor information for your area.

How to Return Parts

Parts may be returned for credit, subject to the conditions of our return goods policy. To obtain authorization to return a part, contact the your Distributor.

Please give the following information:

- Invoice number and date
- Quantity
- Part Number (from parts list)
- Exact reason for return

Your Distributor will provide a Return Goods Authorization. *(Returns will not be accepted without advance authorization.)*

DISTRIBUTOR: _____

ADDRESS: _____

CITY: _____ STATE: _____ ZIP: _____

CONTACT: _____

PHONE: _____

FAX: _____



611 SUGAR CREEK ROAD
DELAVAN, WI 53115 U.S.A.
CUSTOMER SERVICE TELEPHONE
1-800-252-5200 OR 414-728-1900
TOLL FREE TELEFAX
1-800-252-5012 OR 414-728-4904

SERVICE NOTES

SINGLE BODY VALVES

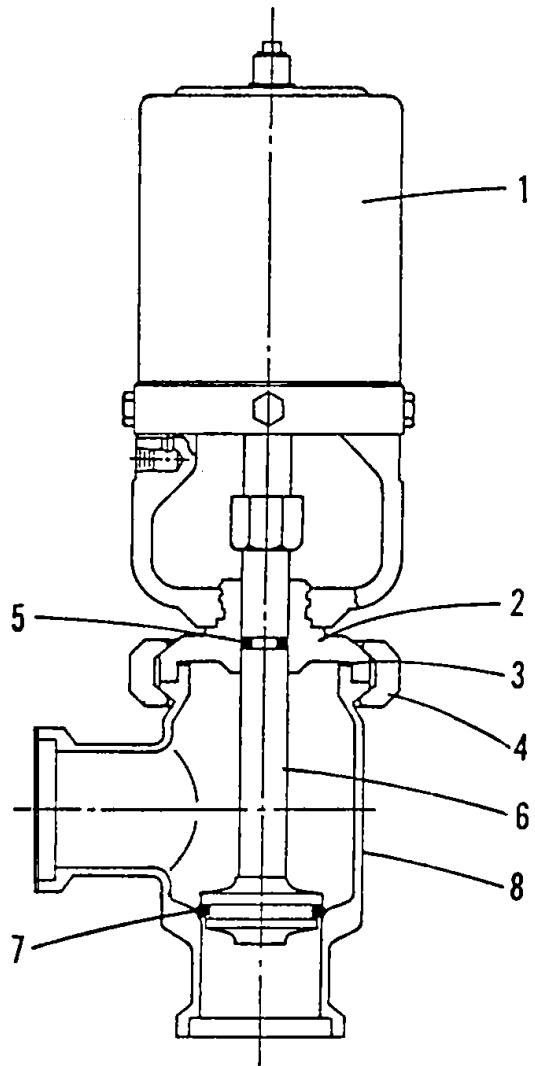
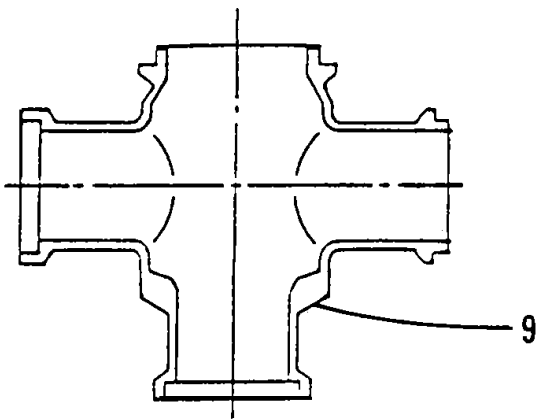

SINGLE BODY VALVES

SINGLE BODY VALVES -- 316 STAINLESS STEEL (Polished and Pickled)

		1½"	2"	2½"	3"	4"	
1. Actuator		See Actuator Parts Listings Pages 22 - 28					
2. Adapter		4788000	4788000	4788300	4788300	3024676	
3. Gasket		20-106	20-106	20-108	20-108	20-259	
4. Clamp		119-232	119-232	4850117	4850117	0546223	
5. O-Ring		9-15N	9-15N	9-15N	9-15N	9-15N	
6. Stem*		Refer to Appendix C, Page 33 before ordering these parts.					
7. Seat Ring*		Refer to Appendix C, Page 33 before ordering these parts.					
8. Tee Body							
	BW	Pickled	3025450	3025460	3025470	3025480	3025490
		Polished	3025451	3025461	3025471	3025481	3025491
	3-A	Pickled	3025452	3025462	3025472	3025482	3025492
		Polished	3025453	3025463	3025473	3025483	3025493
	I	Pickled	3025454	3025464	3025474	3025484	3025494
		Polished	3025455	3025465	3025475	3025485	3025495
	Q	Pickled	3025456	3025466	3025476	3025486	3025496
		Polished	3025457	3025467	3025477	3025487	3025497
	MP	Pickled	3025458	3025468	3025478	3025488	3025498
		Polished	3025459	3025469	3025479	3025489	3025499
9. Cross Body							
	BW	Pickled	3025550	3025560	3025570	3025580	3025590
		Polished	3025551	3025561	3025571	3025581	3025591
	3-A	Pickled	3025552	3025562	3025572	3025582	3025592
		Polished	3025553	3025563	3025573	3025583	3025593
	I	Pickled	3025554	3025564	3025574	3025584	3025594
		Polished	3025555	3025565	3025575	3025585	3025595
	Q	Pickled	3025556	3025566	3025576	3025586	3025596
		Polished	3025557	3025567	3025577	3025587	3025597
	MP	Pickled	3025558	3025568	3025578	3025588	3025598
		Polished	3025559	3025569	3025579	3025589	3025599

DOUBLE BODY VALVES

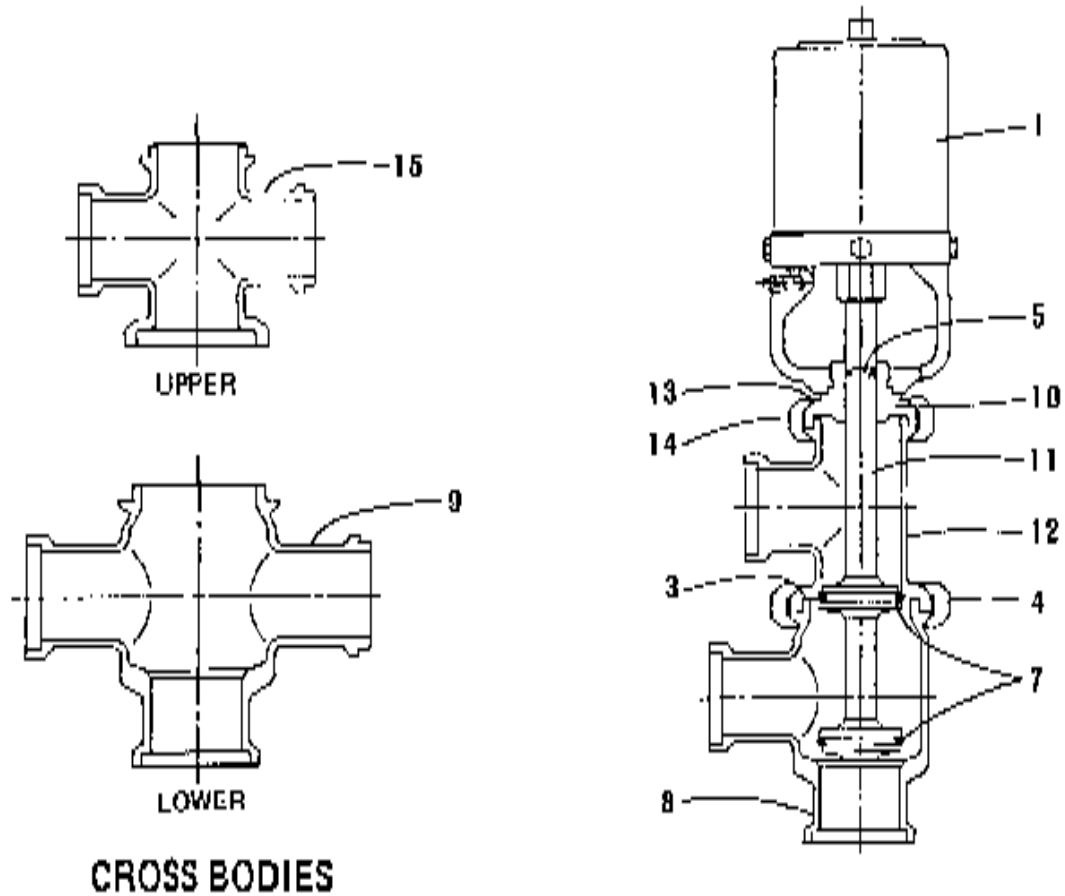

CROSS BODIES

	1½"	2"	2½"	3"	4"
1 Actuator	See Actuator Parts Listing, Page 22-28				
3 Gasket	20-108	20-108	20-108	20-108	20-259
4 Clamp	119-232	119-232	4850117	4850117	0546223
5 O-Ring	9-15N	9-15N	9-15N	9-15N	9-15N
7 Seat *	Refer to Appendix C, Page 33 before ordering these parts.				
8 Lower Body	See Page 21				
9 Lower Body	See Page 21				
10 Adapter	4787800	4787900	4788000	4788100	4788300
11 Stem *	Refer to Appendix C, Page 33 before ordering these parts.				
12 Upper Body	See Page 21				
13 Gasket	20-104	20-105	20-106	20-107	20-108
14 Clamp	119-230	119-231	119-232	119-233	4850117
15 Upper Body	See Page 21				

* Refer to APPENDIX C, Page 31 before ordering parts

DOUBLE BODY VALVES

DOUBLE BODY VALVES -- 316 STAINLESS STEEL (Polished & Pickled)

Table 2. Upper & Lower Bodies -- 316 Stainless Steel

BW		1½"	2"	2½"	3"	4"
Upper Tee Body	Pickled	3025654	3025664	3025674	3025684	3025694
	Polished	3025655	3025665	3025675	3025685	3025695
Upper Cross Body	Pickled	3025754	3025764	3025774	3025784	3025794
	Polished	3025755	3025765	3025775	3025785	3025795
Lower Tee Body	Pickled	3025450	3025460	3025470	3025480	3025490
	Polished	3025451	3025461	3025471	3025481	3025491
Lower Cross Body	Pickled	3025550	3025560	3025570	3025580	3025590
	Polished	3025551	3025561	3025571	3025581	3025591
3-A						
Upper Tee Body	Pickled	3025652	3025662	3025672	3025682	3025692
	Polished	3025653	3025663	3025673	3025683	3025693
Upper Cross Body	Pickled	3025752	3025762	3025772	3025782	3025792
	Polished	3025753	3025763	3025773	3025783	3025793
Lower Tee Body	Pickled	3025452	3025462	3025472	3025482	3025492
	Polished	3025453	3025463	3025473	3025483	3025493
Lower Cross Body	Pickled	3025552	3025562	3025572	3025582	3025592
	Polished	3025553	3025563	3025573	3025583	3025593
I						
Upper Tee Body	Pickled	3025654	3025664	3025674	3025684	3025694
	Polished	3025655	3025665	3025675	3025685	3025695
Upper Cross Body	Pickled	3025754	3025764	3025774	3025784	3025794
	Polished	3025755	3025765	3025775	3025785	3025795
Lower Tee Body	Pickled	3025454	3025464	3025474	3025484	3025494
	Polished	3025455	3025465	3025475	3025485	3025495
Lower Cross Body	Pickled	3025554	3025564	3025574	3025584	3025594
	Polished	3025555	3025565	3025575	3025585	3025595
Q						
Upper Tee Body	Pickled	3025656	3025666	3025676	3025686	3025696
	Polished	3025657	3025667	3025677	3025687	3025697
Upper Cross Body	Pickled	3025756	3025766	3025776	3025786	3025796
	Polished	3025757	3025767	3025777	3025787	3025797
Lower Tee Body	Pickled	3025456	3025466	3025476	3025486	3025496
	Polished	3025457	3025467	3025477	3025487	3025497
Lower Cross Body	Pickled	3025556	3025566	3025576	3025586	3025596
	Polished	3025557	3025567	3025577	3025587	3025597
MP						
Upper Tee Body	Pickled	3025658	3025668	3025678	3025688	3025698
	Polished	3025659	3025669	3025679	3025689	3025699
Upper Cross Body	Pickled	3025758	3025768	3025778	3025788	3025798
	Polished	3025759	3025769	3025779	3025789	3025799
Lower Tee Body	Pickled	3025458	3025468	3025478	3025488	3025498
	Polished	3025459	3025469	3025479	3025489	3025499
Lower Cross Body	Pickled	3025558	3025568	3025578	3025588	3025598
	Polished	3025559	3025569	3025579	3025589	3025599

REPLACEMENT PARTS FOR 4" & 5" ACTUATOR

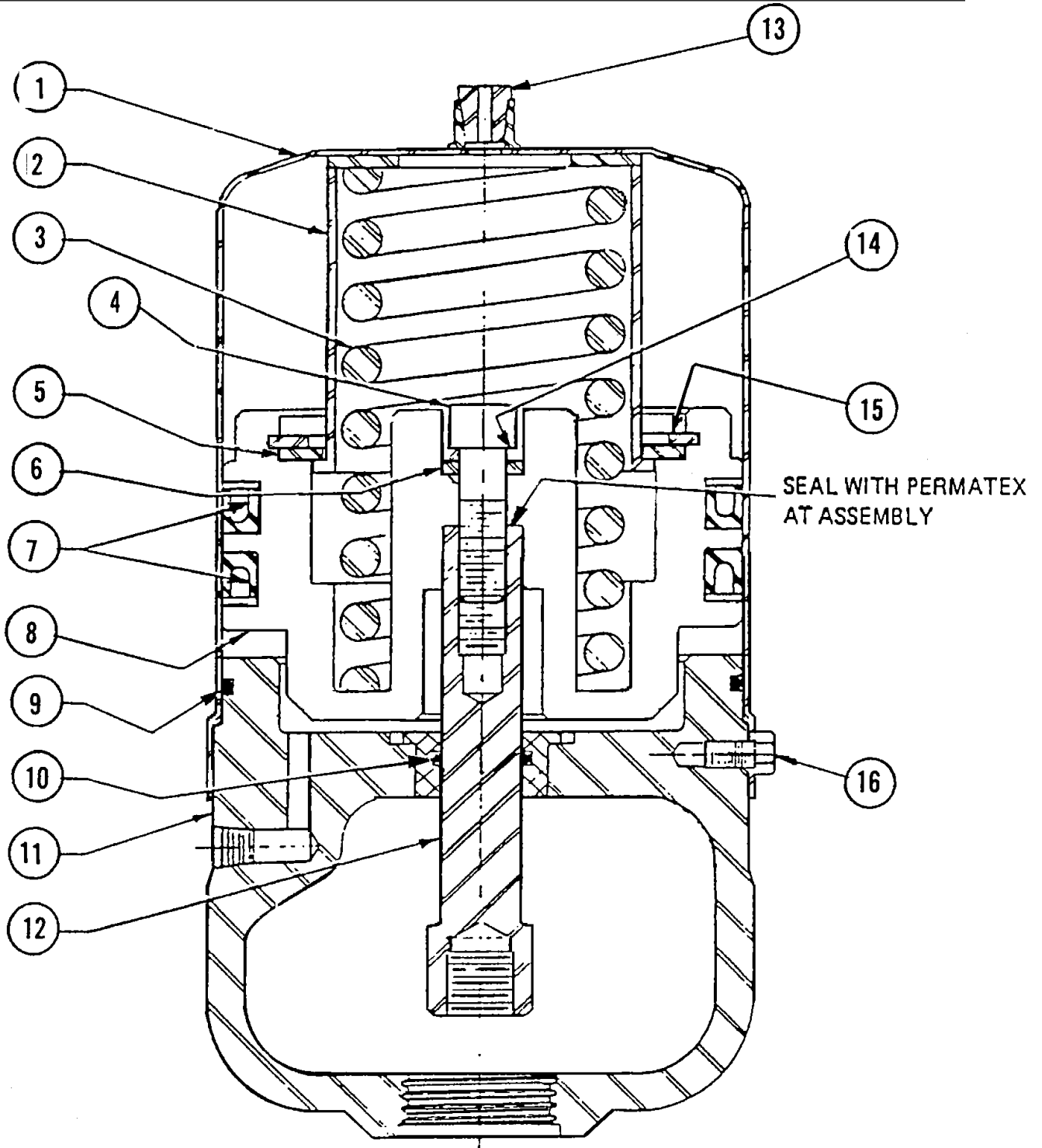

	POLISHED	UNPOLISHED
ORDER NO.	3023970 - AR2-4	8311901 - UAR2-4
	3023969 - AL2-4	8311900 - UAL2-4
	3023972 - AR2-5	8312001 - UAR2-5
	3023971 - AL2-5	8312000 - UAL2-5

REPLACEMENT PARTS FOR 4" & 5" ACTUATOR

4" ACTUATOR

No.	Part No.	Qty.	Description
1	4765701	1	Cylinder-Polished
1	4765700	1	Cylinder-Unpolished
2	3023959	1	Retainer Complete
3	5900032	1	Spring
4	30-332	1	Capscrew; 7/16-14 UNC-2A x 1 1/2"
5	3023958	1	Washer
6	3023961	1	Washer
7	57-15	2	U-Cup Packing
8	3025022	1	Piston
9	9-28	1	O-Ring
10	9-41	1	O-Ring
11	3025330	1	Yoke-Polished
11	3025329	1	Yoke-Unpolished
12	3023960	1	Piston Rod
13	3023957	1	Vent Plug
14	9570210	1	Washer
15	43-58	1	Retaining Ring
16	30-68	4	Capscrew, 1/4-20 UNC-2A x 3/8"

5" ACTUATOR

No.	Part No.	Qty.	Description
1	4765801	1	Cylinder-Polished
1	4765800	1	Cylinder-Unpolished
2	3023964	1	Retainer Complete
3	5900035	1	Spring
4	9522028	1	Capscrew; 7/16-14 UNC-2A x 1 1/2"
5	3023965	1	Washer
6	3023961	1	Washer
7	57-13	2	U-Cup Packing
8	3025024	1	Piston
9	9-96	1	O-Ring
10	9-41	1	O-Ring
11	3025333	1	Yoke-Polished
11	3025332	1	Yoke-Unpolished
12	3023966	1	Piston Rod
13	3023957	1	Vent Plug
14	9570210	1	Washer
15	5900034	1	Retaining Ring
16	30-68	6	Capscrew, 1/4-20 UNC-2A x 3/8"

REPLACEMENT PARTS FOR 4" THREE POSITION ACTUATOR



NOTE

- 1) Coat O-Rings, U-Cups, and their grooves with lubricant.
- 2) Coat all bores, where the shaft may move, with orange solid oil.

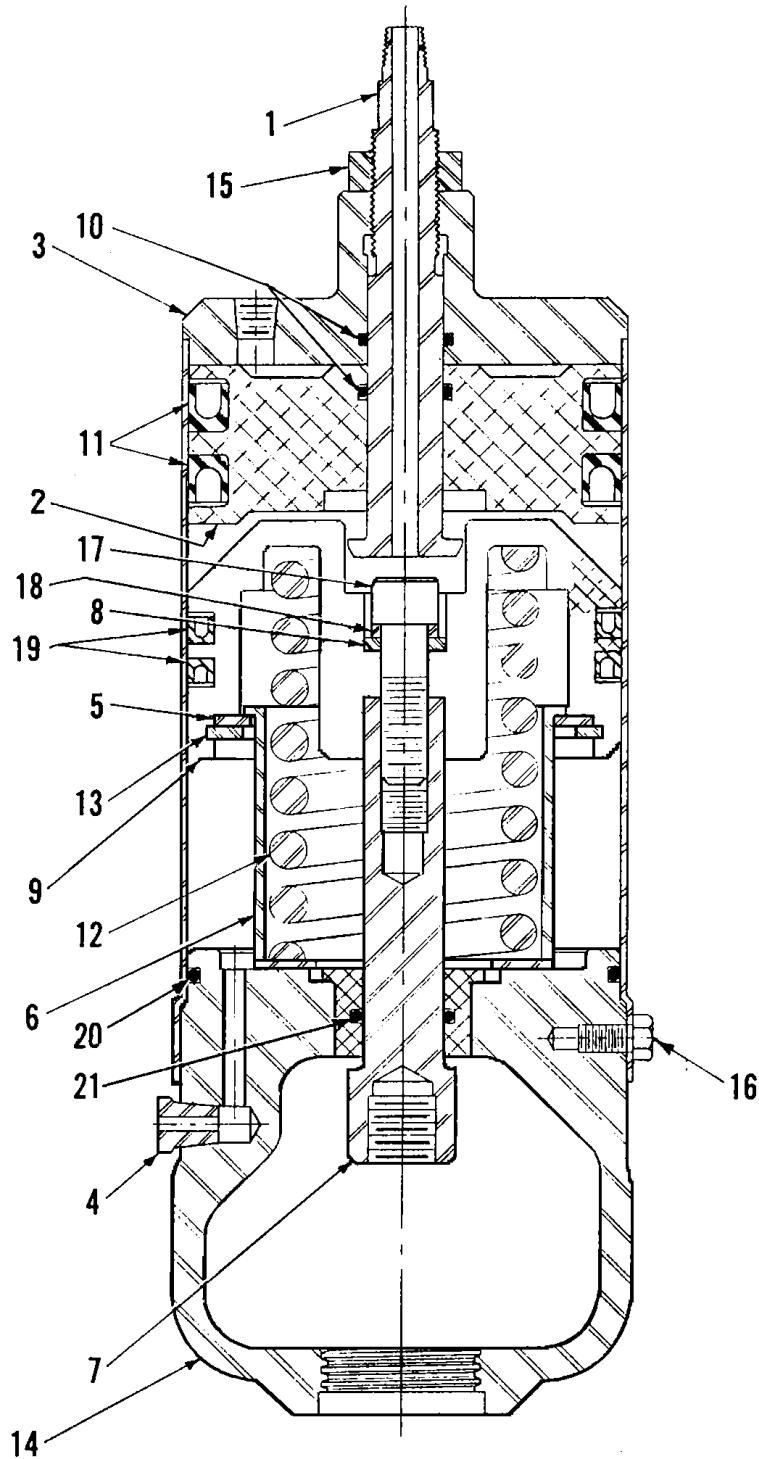

REPLACEMENT PARTS FOR 4" THREE POSITION ACTUATOR

4" THREE POSITION ACTUATOR

No.	Part No.	Qty.	Description
	70197		Assembly Complete -- AL 3-4 The AL 3-4 actuator comes only in the polished finish and in the 4" size. It is usually used on double body valves where the third position is needed during CIP to allow cleaning solution to flow through both valve bodies at the same time. It is an air-to-lower actuator and cannot be reversed.
1	45417	1	STOP
2	70162	1	Upper Piston
3	70177	1	Cylinder
4	302-3957	1	Vent Plug
5	302-3958	1	Washer
6	3023959	1	Retainer
7	3023960	1	Piston Rod
8	3023961	1	Washer
9	3025022	1	Piston
10	5540082	2	O-Ring
11	5540321	2	U-Cup Packing
12	5540032	1	Spring
13	5900033	1	Snap Ring
14	6763500	1	Yoke - Polished
15	9510113	1	Jam Nut - 5/8 - 18 UNF
16	9521001	4	Capscrew
17	9522028	1	Capscrew
18	9570210	1	Washer
19	5541563	2	U-Cup Packing
20	5540223	1	O-Ring
21	5540701	1	O-Ring

REPLACEMENT PARTS FOR MICRO SWITCH ACTUATORS

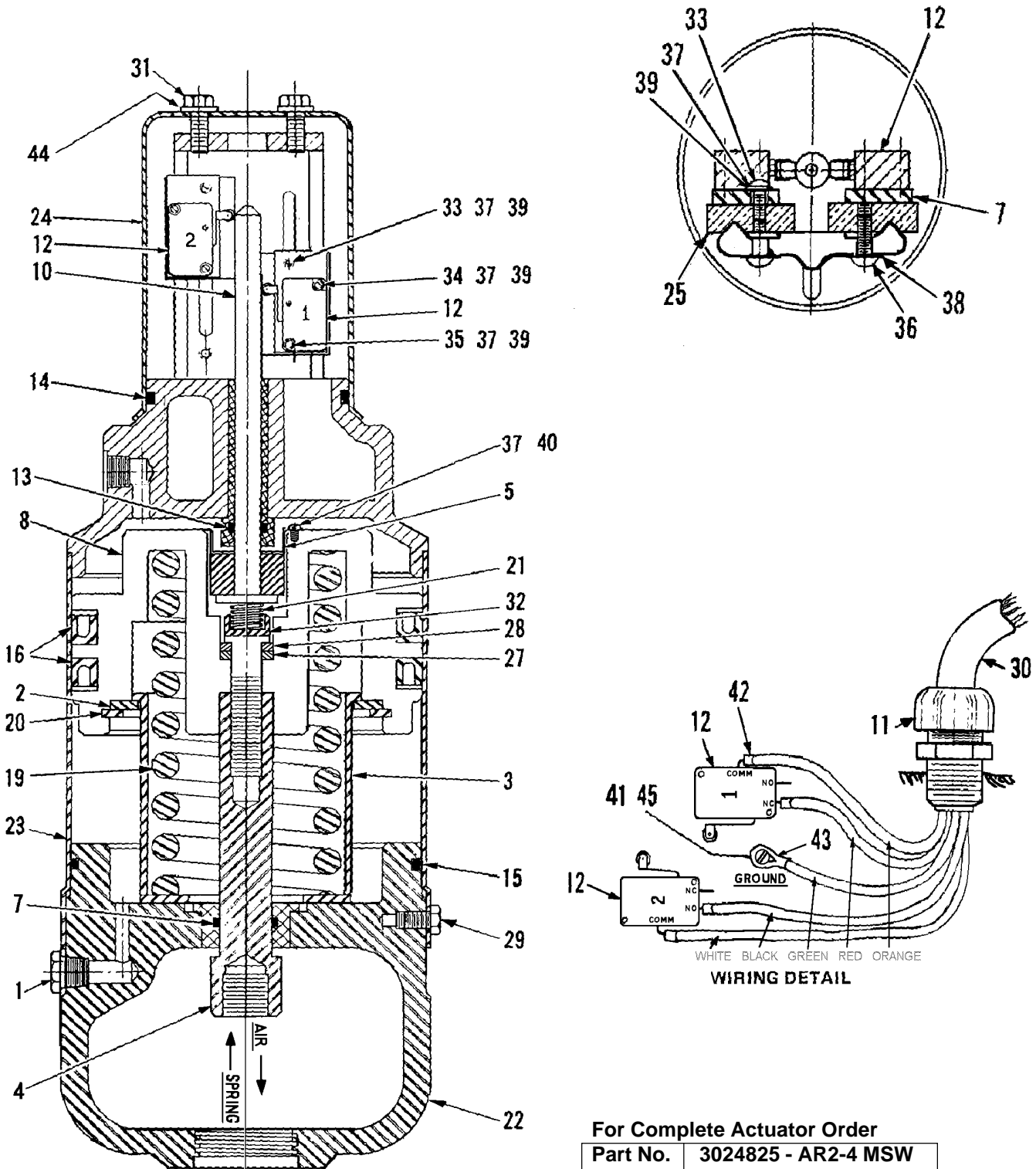

For Complete Actuator Order

Part No.	3024825 - AR2-4 MSW
	3024824 - AL2-4 MSW
	3024823 - AR2-5 MSW
	3024822 - AL2-5 MSW

REPLACEMENT PARTS FOR 4" & 5" MICRO SWITCH ACTUATORS

Item	Description	4" ACTUATOR		5" ACTUATOR	
		Part No.	Qty.	Part No.	Qty.
1	Vent Plug	3023957	1	3023957	1
2	Washer, Collar	3023958	1	3023965	1
3	Retainer	3023959	1	3023964	1
4	Piston Rod	3023960	1	3023966	1
5	Retainer Cup	3024530	1	3024530	1
6					
7	Mounting Plate	3024532	2	3024532	2
8	Piston	3025023	1	3025025	1
9					
10	Micro Switch Rod	3024813	1	3024813	1
11	Connector	5510002	1	5510002	1
12	Micro Switch	5512407	2	5512407	2
13	O-Ring	9-141	1	9-141	1
14	O-Ring	9-26	1	9-26	1
15	O-Ring	9-28	1	9-96	1
16	U-Cup	57-15	2	57-13	2
17	O-Ring	9-41	1	9-41	1
18					
19	Spring	5900032	1	5900035	1
20	Ring Retainer	43-58	1	5900034	1
21	Spring	5902381	1	5902381	1
22	Yoke	3025330	1	3025333	1
23	Cylinder	3024821	1	302480	1
24	Switch Cover	3024819	1	3024819	1
25	Adjustment Block	3024810	2	3024810	2
26					
27	Washer, Upper	3023961	1	3023961	1
28	Washer, 7/16	957-0210	1	957-0210	1
29	1/4-20 x 3/8" Hx Hd Capscrew	30-68	6	30-68	6
30	Cord 18-5 6' Long	9000273	1	9000273	1
31	1/4-20 x 5/8" Hx Hd Capscrew	30-181	2	30-181	2
32	7/16-14 x 1-1/2 Soc Hd Capscr.	30-322	1	30-322	1
33	4-40 x 3/8 Rd Hd Mach Screw	30-199	2	30-199	2
34	4-40 x 5/8 Rd Hd Mach Screw	30-69	2	30-69	2
35	4-40 x 7/8 Rd Hd Mach Screw	30-200	2	30-200	2
36	8-32 x 1/2 Rd Hd Mach Screw	30-143	2	30-143	2
37	#4 Lockwasher Ext. T.	43-162	8	43-162	8
38	#8 Flatwasher	43-26	2	43-26	2
39	#4 Flat Washer	43-125	6	43125	6
40	4-40 x 3/16 Rd Hd Mach Screw	30-198	2	30-198	2
41	6-32 x 3/8 Rd Hd Mach Screw	30-184	1	30184	1
42	90° Terminal	5512421	4	5512421	4
43	Terminal	5510146	1	5510146	1
44	Seal Washer	5541560	2	5541560	2
45	#6 Lockwasher Ext. T.	43-163	1	43-163	1

REPLACEMENT PARTS FOR HAND ACTUATOR

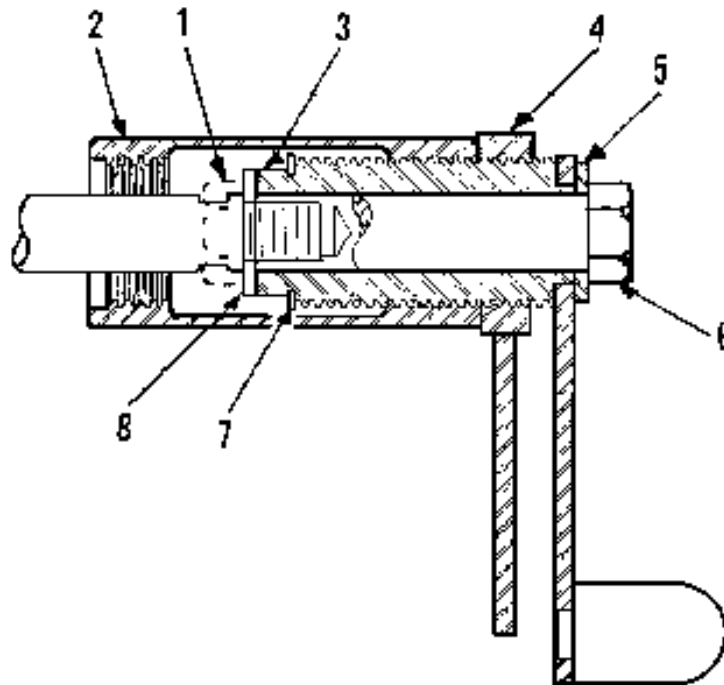

No.	Part No.	Qty.	Description
	302-4621		Assembly
1	952-3016	1	5/8" Capscrew (used to retain parts in assembly only)
2	209-8700	1	Adjusting Nut
3	302-4622	1	Adjusting Screw Assembly
4	210-0700	1	Locknut
5	957-0169	1	3/4" Narrow SS Washer
6	302-4626	1	Stem
7	210-4600	1	Snap Ring
8	957-0165	1	5/8" Narrow SS Washer

If the hand actuator is purchased separately, it will have a 5/8" capscrew installed to retain parts during shipping. When ready to install the actuator on an automatic valve, the cap-screw must be removed and discarded. Save the a 5/8" flat washer (from under the capscrew) as it will be needed during assembly of the valve.

 NO LE
Use Loctite® to secure the stem to actuator.

APPENDIX A

VALVE DIMENSIONS

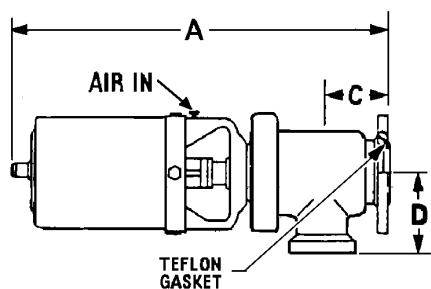

Model 61-TF

Sizes	A	C	D
2"	14-13/16"	2-9/16"	3-9/16"
3"	16-19/32"	3-9/16"	4-1/2"

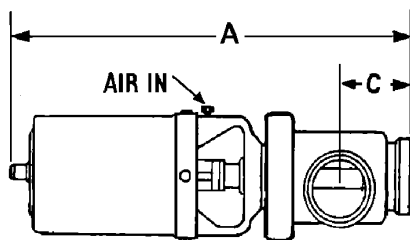

Model 61-TOP

Sizes	A	C	D
2"	15-13/16"	3-9/16"	3-9/16"
2½"	17"	4-3/16"	4-3/16"
3"	17-17/32"	4-1/2"	4-1/2"

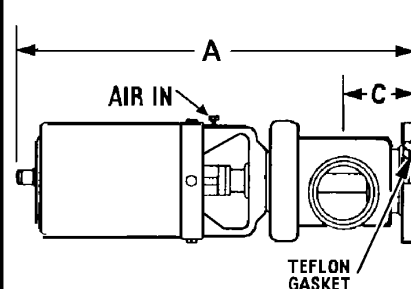

Model 61-TFOP

Sizes	A	C	D
2"	14-13/16"	2-9/16"	3-9/16"
2½"	16-3/16"	3-3/8"	4-3/16"
3"	16-19/32"	3-9/16"	4-1/2"

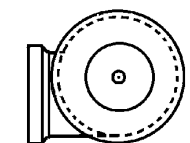

Left hand valve.

To determine a right or left hand valve, look at the valve from the actuator end and position the discharge port for full drainage. The port will point to the right on a right hand valve and to the left on a left hand valve.

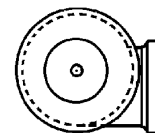

Right hand valve

FLANGE DIMENSIONS

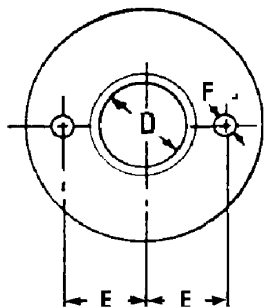

ROUND FLANGE MOUNTING

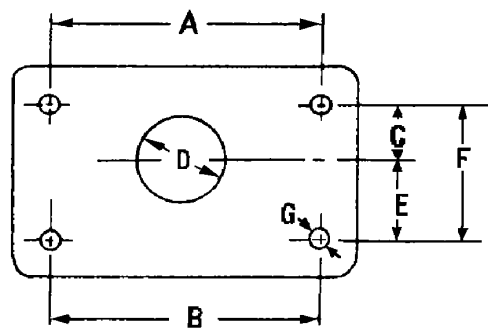

RECTANGULAR FLANGE MOUNTING
(Flange dimensions to be supplied by user.)

	A	B	C	D	E	F	G
2" C-B (Round)				1-7/8	2-1/8	21/32	
3" C-B	6-1/16	6-1/16	2-1/8	2-7/8	1-3/8	3-1/2	17/32
2½" Tri. C.	5	5-1/4	1-1/2	2-3/8	1-5/16	2-13/16	9/16
3" Tri. C.	5-5/8	6-5/8	1-3/4	2-7/8	1-3/4	3-1/2	11/16

APPENDIX A

VALVE DIMENSIONS



Notes:

- 1) Illustrations are for valves with I-line connections.
- 2) I-clamp and other connection dimensions are shown on opposite page.
- 3) "A" dimension is shown for 4" actuator. For 5" actuator, add 1-3/16"; for hand actuator, deduct 2-1/8"; for 4" MSW, add 5-5/8"; for 5" MSW, add 6-7/8".

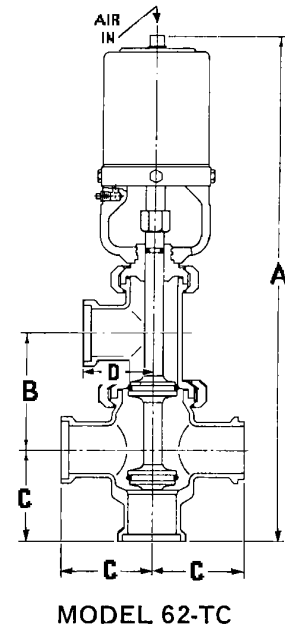
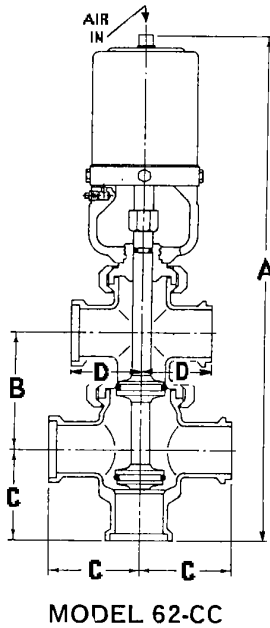
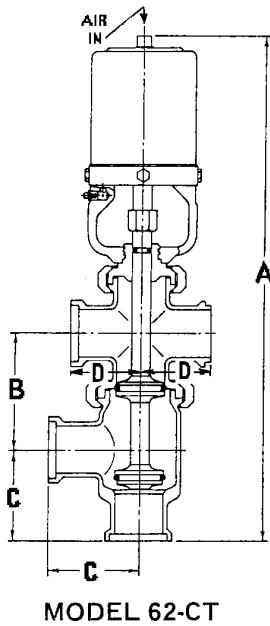
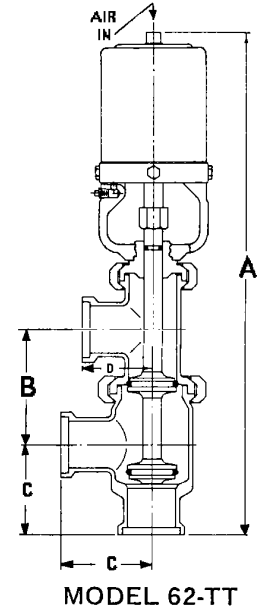
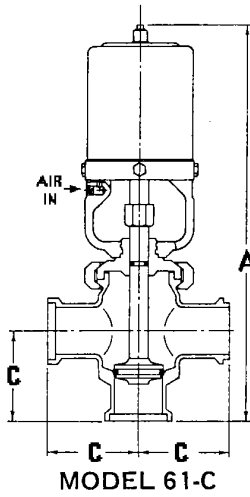
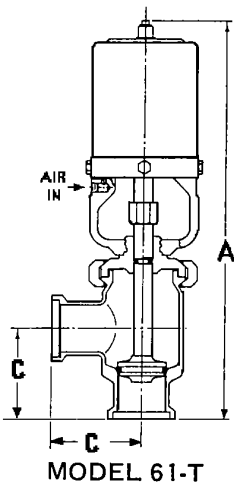

APPENDIX A

"I"-CLAMP (INTERLOCKING DESIGN)

VALVE SIZE	A		B	C	D
	SERIES 61 VALVES	SERIES 62 VALVES	SERIES 62 VALVES ONLY	SERIES 61 & 62 VALVES	SERIES 62 VALVES ONLY
1½	15½	18½	3 ¹⁵ / ₁₆	3½	2 ¹⁹ / ₃₂
2	15 ¹³ / ₁₆	19¾	4 ⁹ / ₁₆	3 ⁹ / ₁₆	3 ¹ / ₁₆
2½	17	21 ¹⁵ / ₁₆	5 ⁹ / ₁₆	4 ³ / ₁₆	3 ⁷ / ₁₆
3	17 ¹⁷ / ₃₂	23½	6½	4½	3¾
4	19 ⁹ / ₁₆	26¼	7½	5¾	4¾

"S"-CLAMP (MP) (FACE-TO-FACE DESIGN)

VALVE SIZE	A		B	C	D
	SERIES 61 VALVES	SERIES 62 VALVES	SERIES 62 VALVES ONLY	SERIES 61 & 62 VALVES	SERIES 62 VALVES ONLY
1½	14 ¹¹ / ₁₆	18 ¹ / ₁₆	3 ¹⁵ / ₁₆	2 ¹¹ / ₁₆	2 ⁵ / ₃₂
2	15 ⁹ / ₃₂	19 ¹¹ / ₃₂	4 ⁹ / ₁₆	3 ¹ / ₃₂	2 ¹⁷ / ₃₂
2½	16 ¹¹ / ₃₂	21 ⁹ / ₃₂	5 ⁹ / ₁₆	3 ¹⁷ / ₃₂	2 ²⁵ / ₃₂
3	16 ¹³ / ₁₆	22 ¹³ / ₃₂	6½	3 ²⁵ / ₃₂	3 ¹ / ₃₂
4	18 ²⁷ / ₃₂	25 ¹⁷ / ₃₂	7½	4 ²¹ / ₃₂	3 ²¹ / ₃₂

BUTT-WELD

VALVE SIZE	A		B	C	D
	SERIES 61 VALVES	SERIES 62 VALVES	SERIES 62 VALVES ONLY	SERIES 61 & 62 VALVES	SERIES 62 VALVES ONLY
1½	14 ⁷ / ₃₂	17 ¹⁹ / ₃₂	3 ¹⁵ / ₁₆	2 ⁷ / ₃₂	2 ¹⁹ / ₃₂
2	14 ¹³ / ₁₆	18¾	4 ⁹ / ₁₆	2 ⁹ / ₁₆	3 ¹ / ₁₆
2½	15¾	20 ¹³ / ₁₆	5 ⁹ / ₁₆	3 ¹ / ₁₆	3 ⁷ / ₁₆
3	16 ¹¹ / ₃₂	21 ¹⁵ / ₁₆	6½	3 ⁵ / ₁₆	3¾
4	18¼	24 ¹⁵ / ₁₆	7½	4 ¹ / ₁₆	4¾

THREADED (BEVEL SEAT)

VALVE SIZE	A		B	C	D
	SERIES 61 VALVES	SERIES 62 VALVES	SERIES 62 VALVES ONLY	SERIES 61 & 62 VALVES	SERIES 62 VALVES ONLY
1½	15½	18½	3 ¹⁵ / ₁₆	3½	2 ¹⁹ / ₃₂
2	15 ¹³ / ₁₆	19¾	4 ⁹ / ₁₆	3 ⁹ / ₁₆	3 ¹ / ₁₆
2½	17	21 ¹⁵ / ₁₆	5 ⁹ / ₁₆	4 ³ / ₁₆	3 ⁷ / ₁₆
3	17 ¹⁷ / ₃₂	23½	6½	4½	3¾
4	19 ⁹ / ₁₆	26¼	7½	5¾	4¾

"A" dimension is for 4" Actuator. For 5" Actuator, add 1-13/16"
 For Hand Actuator, deduct 2-1/8"
 For 4" Micro Switch Actuator, add 5-5/8"
 For 5" Micro Switch Actuator, add 5-5/8"

APPENDIX B

4" AND 5" ACTUATOR - HEAD PRESSURE LOSS CURVES

61 T SERIES

Single Body Shut-Off Valve
Flow Direction
S to B & B to S

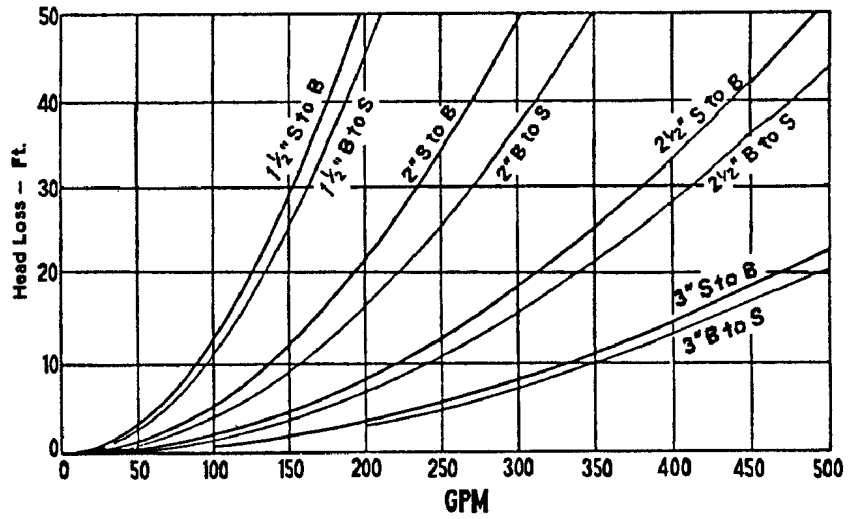
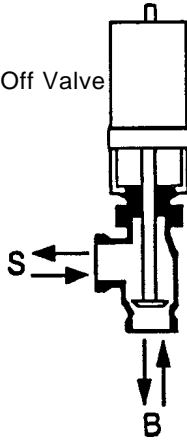

61 C SERIES

Single Body Shut-Off Valve
Flow Direction
S to B & B to S

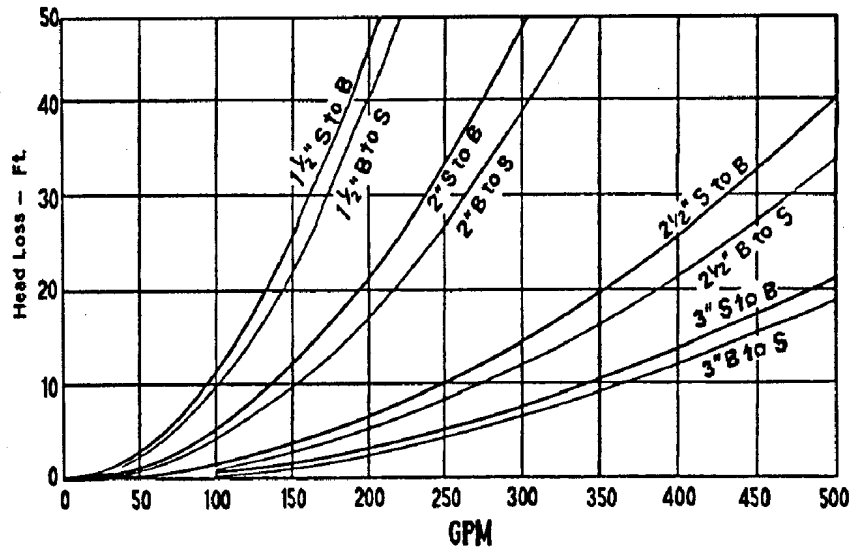
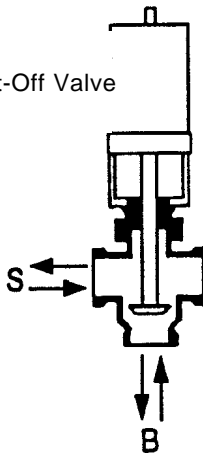

62 TT SERIES

Double Body Divert Valve
Flow Direction S to T
(For S to B see
61 T Series S to B)

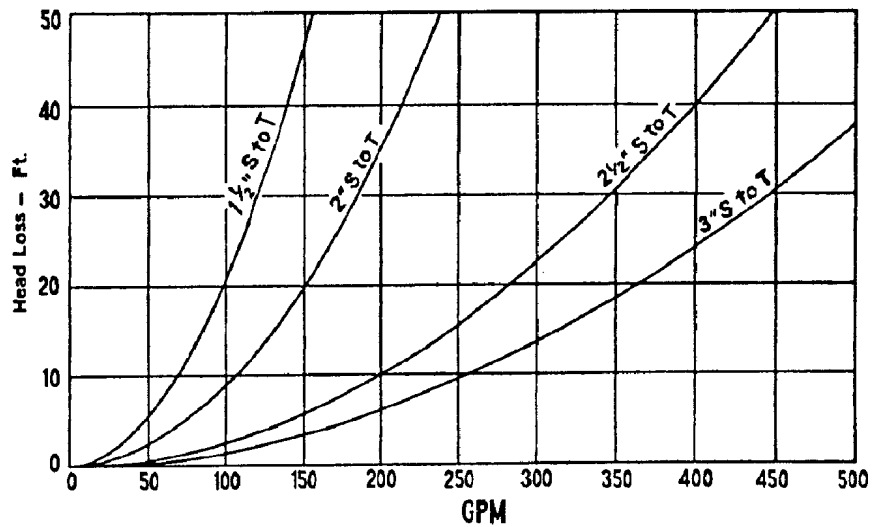
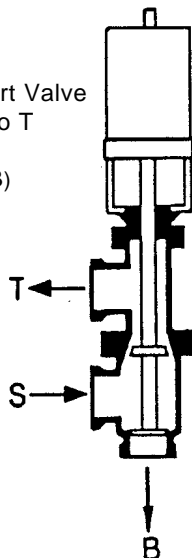

APPENDIX C

SEAT RING & VALVE STEM CROSS REFERENCE CHART

	1½"	2"	2½"	3"
* Seat Rings				
New Style	3025341	3025342	3025343	3024645
Old Style	5540344	5540341	5540342	5540343
Tef-Flow™	20-270	20-241	20-242	20-243
Single Body Stems #316				
New Style	3025815	3025816	3025817	3025818
Old Style	4779010	4779020	4779030	4779040
Tef-Flow™	262-406X	262-409X	262-410X	262-411X
Double Body Stems #316				
New Style	3025820	3025821	3025822	3025823
Old Style	4779210	4779220	4779230	4779240
Tef-Flow™	262-413X	262-414X	262-415X	262-416X

* 2 Required for Double Body Valves

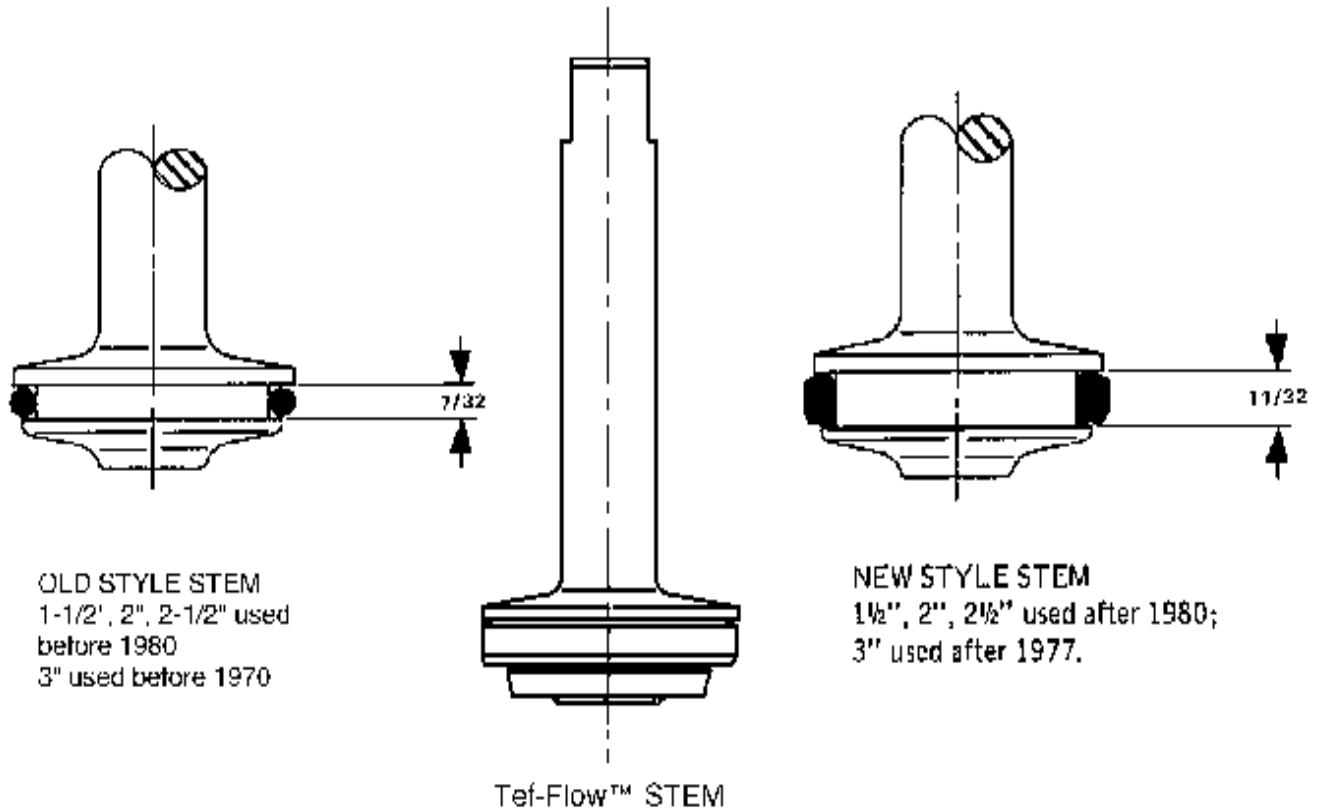

REFERENCE DATA

Stainless Steel Tubing Data

Standard Size (O.D.) inches	1	1½	2	2½	3	4
Volume in cu. in. per ft. of length	7.13	17.69	32.96	52.94	77.63	138.5
Gals. water per ft. of length	.031	.077	.143	.229	.336	.600

1 lb. per sq. in. = 2.31 feet of head
 1 ft. of head = .43 lbs. per sq. in.
 1 U.S. gal. of water = 8.335 lbs.
 1 U.S. gal. = 231 cu. in.
 1 in. of mercury = .491 lbs. per sq. in.
 1 in. of mercury = 13.60 inches of water
 1 cu. ft. of water = 7.481 U.S. gals.
 1 U.S. quart = 947 c.c.

Pipe Size Schedule 5	Nom. Size	1	1½	2	2½	3	4
	Inside Dia.	1.185	1.770	2.245	2.709	3.334	4.334
Volume in cu. in. per ft. of length		13.23	29.56	47.50	69.16	104.76	177.03
Gals. water per ft. of length		.057	.128	.206	.299	.454	.766

FRICTION HEAD IN FEET PER 100 FEET OF STAINLESS STEEL TUBING

Capacity in U.S. G.P.M.	TUBE SIZE - O.D.						Capacity in Thousands of Lbs./Hour
	1"	1½"	2"	2½"	3"	4"	
	16 Ga. .870" I.D.	16 Ga. 1.370" I.D.	16 Ga. 1.870" I.D.	16 Ga. 2.370" I.D.	16 Ga. 2.870" I.D.	14 Ga. 3.834" I.D.	
5	5.0						2.5
10	17.9	2.0					5.0
15	38.0	4.2					7.5
20	64.0	7.2	1.6				10.0
25	97.0	10.8	2.4				12.5
30	136.0	15.1	3.3	1.1			15.0
35	180.0	20.0	4.4	1.4			17.5
40	230.0	26.0	5.7	1.8	.7		20.0
45	286.0	32.0	7.0	2.2	.9		22.5
50	348.0	39.0	8.6	2.7	1.1		25.0
60		54.0	12.0	3.8	1.5		30.0
70		72.0	16.0	5.0	2.0		35.0
80		92.0	20.0	6.5	2.6		40.0
100		138.0	31.0	9.7	3.9		50.0
120		193.0	43.0	13.6	5.4	1.3	60.0
140		257.0	57.0	18.1	7.2	1.8	70.0
160		328.0	73.0	23.0	9.2	2.3	80.0
180			90.0	29.0	11.4	2.8	90.0
200			110.0	35.0	13.8	3.4	100.0
220			131.0	42.0	16.5	4.0	110.0
240			153.0	49.0	19.3	4.8	120.0
260			178.0	56.0	22.4	5.5	130.0
280			204.0	65.0	26.0	6.3	140.0
300			231.0	74.0	29.0	7.2	150.0
350			307.0	98.0	39.0	9.5	175.0
400				125.0	49.0	12.2	200.0
450				155.0	61.0	15.1	225.0
500				188.0	75.0	18.4	250.0
550				224.0	89.0	21.9	275.0
600				263.0	104.0	25.6	300.0
700					138.0	34.0	350.0
800					177.0	44.0	400.0
900					220.0	54.0	450.0
1000					267.0	66.0	500.0
1100						78.0	550.0
1200						92.0	600.0

SERVICE NOTES



**Waukesha
Cherry-Burrell**

®

611 SUGAR CREEK ROAD
DELAVAN, WI 53115 U.S.A.
CUSTOMER SERVICE TELEPHONE
1-800-252-5200 OR 262-728-1900
TOLL FREE TELEFAX
1-800-252-5012 OR 262-728-4904